



&

**8<sup>th</sup> Kurt Schwabe Symposium**

# **Book of Abstracts**

**May 27 – 30, 2019, Split, Croatia**

**7<sup>th</sup> Regional Symposium on Electrochemistry – South East Europe**

&

**8<sup>th</sup> Kurt Schwabe Symposium**

*Split, Croatia, May 27-30, 2019*

## **Book of Abstracts**

*Published by*

**International Association of Physical Chemists**

*E-mail: [office@iapchem.org](mailto:office@iapchem.org), URL: <http://www.iapchem.org>*

For Publisher

**Zoran Mandić**

Editors

**Višnja Horvat-Radošević, Krešimir Kvastek, Zoran Mandić**

Design, Page Making and Computer Layout

**Aleksandar Dekanski**

ISBN 978-953-56942-7-4

On Line version only

# Contents

## PLENARY LECTURES - RSE SEE 7

Advancement in the electrochemical testing and characterization of power sources Daria Vladikova, Blagoy Burdin _____	2
Reaction and transport mechanisms in lithium-sulfur batteries Miran Gaberšček, Sara Drvarič Talian, Jože Moškon, Jan Bitenc, Alen Vižintin, Robert Dominko _____	3
Electrolytic iron production from alkaline suspension of solid oxides: compared cases of hematite, iron ores and iron-containing processing waste Francois Lapicque _____	4
<i>In-situ</i> electrochemical, microscopic and spectroscopic studies of local corrosion and buried metal-polymer interfaces J. M. C. Mol _____	5

## PLENARY LECTURE - 8<sup>th</sup> Kurt Schwabe Symposium

Gas sensing technologies in combustion: A comprehensive review Pavel Shuk, Hans-Ulrich Guth, Chad McGuire _____	7
--------------------------------------------------------------------------------------------------------------------	---

## KEYNOTE LECTURES - RSE SEE 7

The effects of time-variance on impedance measurements: examples on a corroding electrode and a battery cell Nicolas Murer, Jean-Paul Diard, Bogdan Petrescu _____	9
Computationally driven development of novel electrocatalysts Igor A. Pašti _____	10
Formation of disperse deposits by electrolysis: morphology, structure and mechanism Nebojša D. Nikolić _____	11
Molecular modeling of corrosion inhibitors: a search for physically sound descriptors Anton Kokalj, Ingrid Milošev _____	12
Comparison of the protective properties of fatty acid films prepared by different application methods Helena Otmačić Čurković, Ekatarina Kristan Mioč, Zana Hajdari Gretić _____	13
A fifty-years old problem re-visited: the voltammograms of diffusion controlled reactions Tamás Pajkossy _____	14
A new environment-sparing method for preparation of nanomaterials applicable in fuel cells and electrolyzers Jenia Georgieva, N. Dimitrova, S. Sotiropoulos, T. Boiadjeva-Scherzer _____	15
Stereoelectrochemistry of reducible calix[4]arenes Jiří Ludvík, Alan Liška _____	16

## KEYNOTE LECTURES - 8<sup>th</sup> Kurt Schwabe Symposium

Novel electrode materials and arrangements for sensing biologically active organic compounds <i>Jiri Barek</i> _____	18
Results achieved fitting to- and using SECM in corrosion experiments Géza Nagy, Livia Nagy, András Kiss, Dániel Filotás, Abdelilah Assergine, Ricardo M. Souto _____	19

## ORAL PRESENTATIONS - RSE SEE 7

### Batteries and Electrochemical Energy Storage

Improved electrochemical performance of lithium titanate anodes with conductive polymer binder

Veniamin Kondratiev, Svetlana Eliseeva, Ekaterina Shkreba, Mikhail Kamenskii, Elena Tolstopjatova	22
Status, challenges and possible solutions for rechargeable zinc-air flow batteries	
Birgit Pichler, Bernhard Gollas, Viktor Hacker	23
On the validity of using the diffusion coefficient in characterization of charge transfer reactions in systems with a solid-phase reagent	
Viacheslav Barsukov, Volodymyr Khomenko, Oksana Butenko	24
Introduction of differential resistance analysis in battery testing	
Blagoy Burdin, Dimitar Bojchev, Daria Vladikova	25
Morphology control of aluminium anodes in secondary aluminium batteries	
Sandra Steiner, David Moser, Gerald Kothleitner, Bernhard Gollas	26
Porous composite electrode from pyrolyzed rice husk for rechargeable zinc battery	
Kaewta Jetsrisuparb, Sawitta Triamthaisong, Nontipa Supanchaiyamat, Andrew Hunt, Wirat Jarernboon, Chaiyaput Kruehong, Pornnapa Kasemsiri, Prinya Chindapasirt	27
Zeolite based gas-diffusion electrodes for secondary metal air batteries	
Miglena Slavova, Elena Mihaylova, Emilia Mladenova, Blagoy Burdin, Borislav Abrashev, Daria Vladikova	28
The influence of conductivity and pH on the performance of electric double layer capacitors working in neutral electrolytes	
Ilona Acznik, Katarzyna Lota	29
The electrochemical properties of nitrogen-doped carbon materials	
Katarzyna Lota, Ilona Acznik, Agnieszka Sierczynska, Lukasz Kolanowski, Grzegorz Lota	30
Supercapacitors based on reduced graphene oxide hydrogels	
Denis Sačer, Suzana Sopčić, Davor Antonić, Davor Čapeta, Marijana Kraljić Roković	31
Highly efficient carbon-free membrane electrode assemblies for electrolysis cells with anion exchange membrane (AEMEC)	
Galin Borisov, Denis Paskalev, Katerina Maksimova-Dimitrova, Elitsa Petkucheva, Evelina Slavcheva	32
<b>Materials and Electrochemical Processing &amp; Electrochemical Engineering</b>	
The advent of 2D layered materials for electrochemical energy applications	
Rui Gusmão, Zdeněk Sofer, Martin Pumera	34
Electrochemical approaches in synthesis of high surface area materials	
Lidija D. Rafailović, Christoph Gammer, Tomislav Trišović, Bernhard Lutzer, Christian Rentenberger, Aleksandar Z. Jovanović, Igor A. Pašti, H. Peter Karnthaler	35
Cu <sub>2</sub> ZnSnS <sub>4</sub> prepared sulfurizing a stack of electrodeposited metallic layers	
Gonzalo Perelstein, Antonio da Cunha, Marcela Vazquez, Matías Valdés	36
One-pot synthesis of CNT/Ni electrocatalysts using electrophoretic deposition	
Jesper T. N. Knijnenburg, Napapon Massa-Angkul, Kaewta Jetsrisuparb	37
Electrocatalysts incorporating higher fullerenes and DWCNTs	
Georg Pchelarov, Dzhamal Uzun, Konstantin Petrov	38
Tracking and modeling of PtCu nanoalloy dealloying at the atomic-scale: spot the difference “game” at the atomic level	
Nejc Hodnik, Matija Gatalo, Francisco Ruiz-Zepeda, Andraž Pavlišič, Primož Jovanovič, Marjan Bele, Goran Dražić, Miran Gaberšček	39
CO-assisted <i>ex-situ</i> chemical activation of gram-scale high-performance Pt-Cu/C ORR electrocatalyst	
M. Gatalo, L. Moriau, F. Ruiz-Zepeda, P. Jovanovič, U. Petek, N. Hodnik, M. Bele, M. Gaberšček	40
Novel catalysts for water splitting	

Rashko Rashkov, Vasil Bachvarov, Marina Arnaudova, Galin Borisov	41
Comparative study of nanostructured electrocatalytic materials on 3D nickel foam for efficient water splitting	
Elitsa Petkucheva, Galin Borisov, Elefteria Lefterova, Evelina Slavcheva	42
Surface pinning of voids in electromigration testing by anodization of combinatorial Al-Cu alloys	
Saeedeh Ravandi, Tobias Zenger, Martin Eibelhuber, Achim Walter Hassel, Andrei Ionut Mardare	43
Impact of elevated temperature on structural changes of perfluorosulfonated ionomer for polymer electrolyte membrane fuel cells	
Anamarija Stoilova, Matko Erceg, Frano Barbir	44
Fuel cells, a clean and efficient way of producing electricity: Brief description of the different types of fuel cells and their applications	
J. Tartaj	45
Monitoring and evaluation of polymer electrolyte fuel cells under harmful operating conditions	
Mayer Kurt, Hacker Viktor	46
Rejuvenation phenomena of proton exchange membrane fuel cells	
Ivan Pivac, Frano Barbir, Jagoda Radošević	47
Design of polymer coated catalysts for enhanced oxygen reduction reaction toward durable polymer electrolyte fuel cells	
Katharina Kocher, Viktor Hacker	48
Reversibility in a new design of solid oxide fuel cell	
Gergana Raikova, Blagoy Burdin, Emilia Mladenova, Milena Krapchanska, Daria Vladikova, Zdravko Stojnov	49
Combinatorial bandgap tuning of niobium-based anodic oxides for visible light applications	
Andrei Ionut Mardare, Cezarina Cela Mardare, Christoph Cobet, Achim Walter Hassel	50
Electrochemistry of macroscopic CVD-graphene on non-conducting substrates in deep eutectic solvents	
Bernhard Gollas, David Fuchs, Bernhard C. Bayer	51
Electrodeposition of Sn binary and ternary alloys involving deep eutectic solvents	
Liana Anicai, Stefania Costovici, Aurora Petica, Sabrina Rosoiu, Aida G. Pantazi, Teodor Visan	52
An electrochemical process for the simultaneous purification of H <sub>2</sub> S and SO <sub>2</sub>	
Dzhamal Uzun, Elena Razkazova-Velkova, Venko Beschkov Konstantin Petrov	53
<b>Corrosion Science and Protection</b>	
The effect of pre-treatment on the surface chemistry and interfacial properties of sol-gel coating applied on aluminium and aluminium alloys	
Urša Tiringler, Janez Kovač, Shoshan Abrahami, Joost van Dam, Ingrid Milošev, Arjan Mol	55
Sol-gel spray and electrophoretic deposition techniques to enhance bioactive and antibacterial response of titanium implants	
Josefina Ballarre, Tuba Ademir, Liliana Liverani, Aldo R. Boccaccini	56
Hybrid sol-gel coatings modified with fluorinated (meth)acrylates for corrosion protection of AA2024-T3 in 0.5 M NaCl	
Peter Rodič, Dolores Zimerl, Ingrid Milošev	57
Al <sub>2</sub> O <sub>3</sub> and HfO <sub>2</sub> films prepared by atomic layer deposition for protection of commercially pure titanium for biomedical applications	
Ivan Spajić, Ingrid Milošev	58
Functionalization of titanium dioxide coatings for biomedical applications – corrosion impact study	
Barbara Burnat, Andrzej Leniart, Sławomira Skrzypek	59
Improving the anticorrosive properties of chitosan coatings by impregnation with inhibitors	

Árpád Ferenc Szőke, Gabriella Stefánia Szabó, Zoltán Hórvölgyi, Emőke Albert, Liana Maria Muresan _____	60
The influence of surface preparation on efficiency of mercapto and phosphonic inhibitors adsorbed on aluminium and copper metal	
Dževad K. Kozlica, Ingrid Milošev _____	61
Testing inorganic ions as “green” corrosion inhibitors for construction steel	
Francisco Montes, Lucía Yohai, Marcela Vazquez, María B. Valcarce _____	62
Metal surface microstructure and inhibitor performance	
Emeka E. Oguzie, Lui Li, Maduabuchi A. Chidiebere, Pan Chen, Ying Li, Fuhui Wang _____	63
<b>Organic Electrochemistry and Bioelectrochemistry</b>	
Electrochemical investigation of fluorinated derivatives of 1,3-diphenylisobenzofuran, chromophores for singlet fission	
Ludmila Šimková, Jiří Ludvík _____	65
Spectroelectrochemical studies of perfluoroalkylated derivatives of PAHs	
Peter Machata, Alexey Popov, Tyler T. Clikeman, Eric V. Bukovsky Steven H. Strauss, Olga V. Boltalina _____	66
Effect of tripodal anchoring groups ( <i>meta</i> versus <i>para</i> position) on the charge transport in single oligophenylene molecular wires	
Magdaléna Hromadová, Viliam Kolivoška, Jakub Šebera, Táňa Sebechlebská, Jindřich Gasior, Štěpánka Nováková Lachmanová, Gábor Mészáros, Marcin Lindner, Marcel Mayor, Michal Valášek _____	67
Electrochemical properties of substituted thioxothiazolidin-azulene	
Veronica Anăstasoae, Laura Enache, Mihaela Cristea, Raluca Isopescu, Gabriela Stanciu, Eleonora-Mihaela Ungureanu _____	68
On the reaction of polyphenols with copper dication	
Romana Sokolová, Veronika Majarová, Michaela Obluková, Jan Vacek, Vladimír Křen _____	69
Electrochemical behaviour of toluylene blue	
D. Vishenkova, E. Korotkova, J. Barek _____	70
<b>Electroanalytical Chemistry and Sensors</b>	
Insights into copper film electrodes for voltammetric determination of trace toxic elements	
Vasko Jovanovski, Nana Ivana Hrastnik, Urša Klun _____	72
Understanding the gold microwire electrode behavior for the detection of trace metals	
Nevila Broli, Majlinda Vasjari _____	74
Novel methodology for investigating electrochemical gas evolution reactions: a case study of oxygen evolution reaction using floating electrode for effective oxygen bubble removal	
Primož Jovanovič, Kevin Stojanovski, Marjan Bele, Luka Suhadolnik, Goran Dražić, Gorazd Koderman Podboršek, Miran Gaberšček, Nejc Hodnik _____	75
Development of hydrogen peroxide gas sensor for security applications	
J. Isailović, V. Jovanovski, P. Jovanovič _____	76
Development of ISE-Cl <sup>-</sup> using modified polymeric membrane	
Majlinda Vasjari, Nevila Broli, Sadik Cenolli _____	77
<b>General Topics and Physical Electrochemistry</b>	
Investigation of the vanadium redox system by dual voltammetry	
Mária Ujvári, Soma Vesztergom, Szabolcs Gyulai-Gaál, Gyöző G. Láng _____	79
A model for hydrogen evolution on RDEs: Are the limiting current plateau lengths indicative of electrocatalytic activity?	
Soma Vesztergom, María de Jesús Gálvez-Vázquez, Vitali Grozovski, Noémi Kovács, Peter Broekmann _____	80
Ammonia synthesis under ambient conditions by electrochemical nitrogen reduction	

Viktor Čolić, Sungeun Yang, Suzanne Z. Andersen, Kasper Enemark-Rasmussen, Peter C.K. Vesborg, Ifan E.L. Stephens, Jakob Kibsgaard, Ib Chorkendorff	81
On the electrochemical reduction of molecular oxygen in coexisting equilibrium phases of solutions of limited miscibility	
Gyöző G. Láng, Mária Ujvári	82
Investigation of the electrochemical behaviour of bisphenol A on gold in contact with 0.1 M aqueous NaClO <sub>4</sub> solution	
Krisztina J. Szekeres, Éva Fekete, Gyöző G. Láng	83
<b>8<sup>th</sup> Kurt Schwabe Symposium</b>	
Kurt Schwabe – Name given of an international symposium	
Vonau Winfried	85
Coulometric titration of oxygen in the picomol range	
Alexander Herms, Jingying Yao, Jens Zosel, Wolfram Oelßner, Michael Mertig	86
In situ observation of crevice corrosion by a modified chemical imaging sensor system	
Ko-ichiro Miyamoto, Tatsuo Yoshinobu	87
Corrosion screening of dysprosium-magnesium-zinc alloys for bioresorptive implants	
Dominik Recktenwald, Cezarina Cela Mardare, Andrei Ionut Mardare, Achim Walter Hassel	88
Adrenaline biosensing – from macroelectrode to chip-based biosensor to support tumor diagnosis	
Denise Molinnus, Petra Siegert, Holger S. Willenberg, Arshak Poghossian, Michael Keusgen, Michael J. Schöning	89
Electrooxidation of nucleobases on disposable electrodes investigated by electrochemistry-capillary electrophoresis-mass spectrometry	
Thomas Herl, Daniel Böhm, Frank-Michael Matysik	90
Electrochemical biosensors for on-line monitoring of biogas processes	
Johanna Pilas, Shahriar Dantism, Desiree Röhlen, Thorsten Selmer, Torsten Wagner, Michael Keusgen, Patrick Wagner, Michael J. Schöning	91
Pulse polarization measurements on the system Pt YSZ by varying the polarization voltage	
Nils Donker, Anastasiya Ruchets, Daniela Schönauer-Kamin, Jens Zosel, Ulrich Guth, Ralf Moos	92
Selective multi-gas measurements with solid electrolyte cells operated by cyclovoltammetry	
Anastasiya Ruchets, Nils Donker, Daniela Schönauer-Kamin, Ralf Moos, Jens Zosel, Ulrich Guth, Michael Mertig	93
Comparison of different screen printed sensors based on carbon paste with incorporated Prussian blue nanoparticles as electrode material for hydrogen peroxide detection	
Anne Müller, Susan Sachse, Manfred Decker, Frank-Michael Matysik, Winfried Vonau	94
Investigations about the simultaneous potentiometric determination of pH-value and potassium amount in freshly sampled soil on-site on the field	
Manfred Decker, Arnold Wezel, Robert Hasler, Petra Teichmann, Martin Schneider, Winfried Vonau	95
Hydrodynamic scanning electrochemical microscopy	
Timo Raith, Christian Iffelsberger, Stefan Wert, Frank-Michael Matysik	96

## POSTER PRESENTATIONS

### Batteries and Electrochemical Energy Storage

Comparative study of synthesis way influence on the electrochemical behaviour of NMC 811

Krum Banov, Iliyan Popov, Todor Petkov, Branimir Banov	99
Lithium diffusion properties of Fe <sub>3</sub> O <sub>4</sub> nanoparticles as different morphologies for anode materials of lithium ion batteries	
Jong Seok Kim, Dae Won Kim, Tae Hyun Kim	100
Silicon as anode for lithium-ion batteries	
Matea Raić, Lara Mikac, Zoran Mandić, Vedran Petrić, Mile Ivanda	101
Electrochemical performance of nanotube sodium titanate in hybrid Li-Mg ion cells	
Sv. Veleva, E. Zhecheva, P. Polrolniczak, A. Stoyanova, R. Stoyanova	102
Synthesis and study of phosphorus sulfide-based electrodes for lithium-ion and sodium-ion batteries	
Yuliya Kudryashova, Dmitrii Gryzlov, Anna Kuz'mina, Tatiana Kulova, Alexander Skundin	103
Study of the lithium insertion into germanium nanofilaments	
Anna Kuz'mina, Il'ya Gavrilin, Yuliya Kudryashova, Tatiana Kulova, Alexander Skundin	104
Nickel-manganese sulfates as electrode materials for hybrid lithium–sodium ion cell	
Delyana Marinova, Rosica Kukeva, Ekaterina Zhecheva, Radostina Stoyanova	105
Modelling of sodium manganese-based sulfates as a new class of polyanion electrode materials	
Delyana Marinova, Rosica Kukeva, Ekaterina Zhecheva, Radostina Stoyanova	106
Effect of Mg-doping on the electrochemical properties of NaMn <sub>1-x</sub> Mg <sub>x</sub> PO <sub>4</sub> phospho-olivine electrodes	
Tanya Boyadzhieva, Violeta Koleva, Radostina Stoyanova	107
Mixed Fe/Mn based phospho-olivines as electrodes in hybrid metal-ion batteries	
Tanya Boyadzhieva, Violeta Koleva, Radostina Stoyanova	108
Gas diffusion electrodes (GDEs) for MH-Air battery systems	
Borislav Abrashev, George Pchelarov, Konstantin Petrov	109
Reduced graphene oxide/ $\alpha$ -Fe <sub>2</sub> O <sub>3</sub> fibres as active material for supercapacitor application	
Gabrijela Radić, Ivan Šajnović, Marijana Kraljić Roković, Željka Petrović	110
PEDOT-based composites prepared by one-step electrochemical method for supercapacitors applications	
Gabrijela Ljubek, Nikola Vugrinec, Marijana Kraljić Roković	111
Electrochemical performance of symmetric supercapacitors based on carbon biomaterials in different electrolytes	112
B. Karamanova, Sv. Veleva, A. Stoyanova, R. Stoyanova	112
Microwave-assisted polyol synthesis of Pt based catalysts: enhanced methanol activity and CO tolerance	
Sanja Stevanović, Vladislava M. Jovanović	113
Ni-Sn coating as electrocatalyst for ethanol oxidation in alkaline solution	
Jelena Lović, Vladimir Jović	114
<b>Materials and Electrochemical Processing and Electrochemical Engineering</b>	
Electrochemical performances of rare earth Co-based mixed oxides and their application as supercapacitors and fuel cells	
Sanja Eraković, Miroslav Pavlović, Srećko Stopić, Miodrag Mitrić, Miroslava Varničić, Jasmina Stevanović, Vladimir Panić, Bernd Friedrich	116
Electrodeposition of NiCo alloy powders with coral-like structure	
Vesna Maksimović, Milovan Stoilković, Nebojša Nikolić	117
Preparation of Pt-IrO <sub>2</sub> /TiO <sub>2</sub> bi-functional catalysts	
Nina Dimitrova, J. Georgieva, S. Sotiropoulos, Tz. Boiadjeva-Scherzer	118
Catalysis at nano level: Promoting Pt nanoparticle activity by Au decoration	

Mila N. Krstajić Pajić, Sanja I. Stevanović, Vuk V. Radmilović, Piotr Zabinski, Nevenka R. Elezović, Velimir R. Radmilović, Snežana Lj. Gojković, Vladislava M. Jovanović _____	119
Surface modification of titanium implants by adherent hydroxyapatite/titanium oxide composite coatings using novel <i>in-situ</i> synthesis	
Marijana Pantović Pavlović, Sanja Eraković, Miroslav Pavlović, Ljiljana Veselinović, Jasmina Stevanović, Vladimir Panić, Nenad Ignjatović _____	120
Poly(vinyl alcohol)/chitosan hydrogels with electrochemically synthesized silver nanoparticles for wound dressing applications	
Vesna Mišković-Stanković, Katarina Nežović, Ana Janković, Tamara Radetić, Aleksandra Perić-Grujić, Maja Vukašinović-Sekulić, Vesna Kojić, Kyong Yop Rhee _____	121
Optimisation of experimental parameters for the electrochemical monitoring of the metals concentration during the waste printed circuit boards recycling process	
Graziella Liana Turdean, Eniko Kovacs, Sorin-Aurel Dorneanu _____	122
Voltammetric study of base metals recovery from brominated solutions used as lixiviants for waste printed circuit boards	
Liana Maria Muresan, Sorin Dorneanu, Eniko Kovacs, Simona Varvara, Petru Ilea _____	123
An EIS study of metals dissolution mechanism in bromide-based electrolytes used as lixiviants for waste printed circuit boards	
Simona Varvara, Sorin Aurel Dorneanu, Alexandru Okos, Roxana Bostan, Maria Popa, Liana Maria Muresan, Petru Ilea _____	124
Magnetic biomass-derived pyrolytic carbon: an advanced electrode material for applications in bioelectrocatalysis and electrochemical sensing	
Egon Rešetar, Damir Iveković _____	125
Design of semiconductor (photo)catalysts and investigation of their electronic structure	
Jozefina Katić, Zoran Grubač, Mirjana Metikoš-Huković _____	126
Frequency response analysis of oxygen reduction reaction in alkaline media	
Saikrishnan Kandaswamy, Tanja Vidaković-Koch _____	127
Mitigating mass transport limitations of PEFCs during dynamic operation	
Bernhard Marius, Zeljko Penga, Viktor Hacker _____	128
Enhancement of the mass transport by numerical simulation in an electrochemical reactor with concentric cylindrical electrodes	
Petru Ilea, Marius Ioan Purcar, Sorin-Aurel Dorneanu, Alexandru Horațiu Marincea _____	129
<b>Corrosion Science and Protection</b>	
Corrosion behaviour of Al alloys in reline	
Mihael Bučko, Jelena B. Bajat _____	131
Substitution of chromium conversion coatings (CCC) by cerium oxide layers (CeOPL) deposition for protection of aluminium aircraft alloys	
Christian Girginov, Stephan Kozhukharov _____	132
Evaluation of the electrochemical performance of Ag incorporated AAO layers after extended exposure to a model corrosive medium	
Stephan Kozhukharov, Christian Girginov, Aleksandar Tsanev, Georgy Avdeev, Boriana Tzaneva _____	133
From organic synthesis to testing of compounds with different anchor groups as corrosion inhibitors for aluminium	
Dolores Zimerl, Stojan Stavber, Ingrid Milošev _____	134
Sol-gel coating based on zirconium(IV) isopropoxide and epoxysilane for corrosion protection of aluminium alloy in deep-sea environment	

Barbara Kapun, Ingrid Milošev _____	135
Corrosion resistance of niobium coatings on copper bipolar plates for proton exchange membrane electrolyzers	
Andrea Kellenberger, Nicolae Vaszilcsin, Delia Duca, Mircea Laurentiu Dan, Narcis Duteanu, Svenja Stiber, Pia Assmann, Aldo S. Gago, K. Andreas Friedrich _____	136
Efficiency testing of commercial corrosion inhibitor for stainless steel EN 1.4301 and copper EN 13601 in simulated cooling water	
Borislav N. Malinović, Duško Zorić, Tijana Đuričić _____	137
Silica/graphene oxide composite coatings for corrosion protection of zinc	
Tamara-Rita Ovari, Gabriella Szabo, Gabriel Katona, Liana Maria Muresan _____	138
Formation and stability of protective films of phosphonic acid on various metal substrates	
Dajana Mikić, Mia Gotovuša, Andreja Kišić, Helena Otmačić Čurković _____	139
Corrosion protection of tin by some carboxylic acids in sodium chloride solution	
Ivana Škugor Rončević, Nives Vladislavić, Marijo Buzuk, Maša Buljac, Anđela Lukin _____	140
The synergistic inhibition of Vitamin E and K <sub>3</sub> in hydrophobic coatings on copper	
Regina Fuchs-Godec _____	141
Corrosive wear degradation of Ti-based implant alloy	
Ivana Cvijović-Alagić, Zorica Cvijović, Jelena Bajat, Marko Rakin _____	142
Surface modification of Ti dental implant by bioactive coatings: experimental and theoretical studies	
Jozefina Katić, Ankica Šarić, Ines Despotović, Marin Petković, Katarina Varzić, Mirela Leskovic, Željka Petrović _____	143
<b>Electroanalytical Chemistry and Sensors</b>	
Electrochemical-biosensor for the detection of coliform presence in drinking water	
Teri Bigham, Charnete Casimero, James Dooley, Nigel Ternan, William Snelling, James Davis _____	145
Electrochemical, zeta-potential and particle size characterization of groundwater samples	
Žana Kajinić, Jelena Vešligaj Turkalj, Željka Romić, Anamarija Stanković, Maja Dutour Sikirić, Martina Medvidović-Kosanović _____	146
Electrochemical determination of nitric oxide in human macrophage	
Valentina Popova, Elena Korotkova, Jiri Barek _____	147
Sequential analysis of Pb(II) traces using unmodified and modified SPE electrodes	
Matjaž Finšgar, David Majer, Uroš Maver, Tina Maver _____	148
Analytical applications of new chemically modified electrodes based on crown ether for heavy metal analysis	
Alexandru Anton Ivanov, Elena Diacu, Eleonora-Mihaela Ungureanu, Sabina-Vasilica Pistol, Adinuta Paun, Magdalena-Rodica Bujduveanu _____	149
Modified electrodes with thiosemicarbazone receptors for metal ions complexation	
George-Octavian Buica, Matei D. Raicopol, Nicoleta A. Chira _____	150
Voltammetric determination of drug based on indomethacin menthyl ester	
Olga Lipskikh, Elena Korotkova, Alena Nikolaeva, Jiri Barek _____	151
Voltammetric characterization and trace level determination of dopamine by carbon paste electrode surface modified with oxidized multiwalled carbon nanotubes	
Jasmina Anojčić, Valéria Guzsányi, Zoltán Kónya, Momir Mikov _____	152
Adsorptive stripping voltammetric determination of fungicide carbendazim by tetrabutylammonium chloride modified carbon paste electrode	
Sanja Šekuljica, Valéria Guzsányi, Kurt Kalcher _____	153
Electrochemical behaviour of methyl 3-mercaptopropionate (3-MPA) at the Hg electrode	

Ana Cvitešić Kušan, Irena Ciglenečki	154
The SWV determination of esomeprazole at Au and its degradation at IrO <sub>x</sub> followed by HPLC and LC-MS M. Avramov Ivić, J. Lović, N. Trišović, J. Lađarević, A. Mladenović, M. Jadrnin, S. D. Petrović, D. Mijin	155
Study of electroactive properties of a new tetrazole azulene derivative for modified electrodes Elena Diacu, Eleonora-Mihaela Ungureanu, Alexandru Anton Ivanov, Sabina-Vasilica Pistol, Veronica Anăstasoae, Cristian Omocea, Liviu Bîrzan	156
Electrochemical behaviour of new (azulen-1-ylidiazonyl)-heteroaromatic compounds containing 1,2,5-thiadiazol-3-yl moieties Veronica Anăstasoae, Laura Enache, Cristian Omocea, Liviu Bîrzan, Raluca Isopescu, Eleonora-Mihaela Ungureanu	157
<b>Organic Electrochemistry and Bioelectrochemistry</b>	
Electrochemical properties of 1-pentyl-3-(1-naphthoyl)indole and 1-pentyl-3-(2-methoxyphenyl-acetyl)indole Michaela Obluková, Romana Sokolová, Ilaria Degano, Radomír Čabala	159
Electrochemical study on biomimetic activity of selected copper complexes in comparison with enzymes Tomáš Mikysek, Milan Sýs, Miroslav Novák	160
<b>General Topics</b>	
Coatings of chitosan/gelatin/Si-Ge nanoparticles by electrophoretic deposition on surgical grade stainless steel: electrochemical and antibacterial behaviour Josefina Ballarre, Aldo R. Boccaccini, Silvia M. Ceré	162
A study on property and performance according to the pore structure of metallic porous separator for hydrogen fuel cell vehicles Myong Hwan Kim, Youngmo Goo, Ji-Young Park, Seung-Eul Yoo	163
An interaction of nanostructured carbon based composites with electromagnetic waves in the wide frequency range Viacheslav Barsukov, Volodymyr Khomenko, Oksana Butenko, Ilona Senyk	164
pH-anion interplay in the electrochemical dissolution of platinum Cornelia Diac, Cătălin Ceauș, Elena Iulia Cuculea, Valeriu Filip, Șerban Stamatina	165
<b>8<sup>th</sup> Kurt Schwabe Symposium</b>	
New electrochemical and physical measurements on sensitive glasses in thin-film technology Frank Gerlach, Kristina Ahlborn, Winfried Vonau	167
Application of a glassy carbon in the voltammetric determination of pesticides Andrzej Leniart, Mariola Brycht, Barbara Burnat, Sławomira Skrzypek	168
Combined calorimetric gas sensor/spore-based biosensor for monitoring of gaseous sterilization processes Jan Oberländer, Julio Arreola, Michael Keusgen, Michael J. Schöning	169
Development of a field-effect biosensor to control the acetoin concentration during fermentation processes Melanie Jablonski, Denise Molinnus, Lukas Muschallik, Johannes Bongaerts, Torsten Wagner, Thorsten Selmer, Petra Siegert, Michael Keusgen, Michael J. Schöning	170
A simple approach for the preparation of ring ultramicroelectrodes in the context of combined scanning electrochemical microscopy and scanning ion conductance microscopy Stefan Wert, Timo Raith, Frank-Michael Matysik	171
<b>Satellite Student Symposium</b>	
Electrochemical analysis of cobalt, nickel and selenium codeposition process from acidic solutions	

Dawid Kutyla, Katarzyna Skibińska, Anna Kwiecińska, Karolina Kołczyk- Siedlecka, Piotr Żabiński, Remigiusz Kowalik _____	173
Synthesis of copper 1D nanocone array electrodes using aluminum oxide template Katarzyna Skibinska, Karolina Kolczyk-Siedlecka, Dawid Kutyla, Anna Kwiecinska, Remigiusz Kowalik, Piotr Zabinski _____	174
IrO <sub>2</sub> /TiO <sub>2</sub> : synthesis and characterization Nina Dimitrova, J. Georgieva, S. Sotiropoulos, Tz. Boiadjieva-Scherzer _____	175
Investigation of Ir deposited on different non-carbon supports as catalyst for OER in PEMEC Iveta Boshnakova, Elefteria Lefterova, Denis Paskalev, Evelina Slavcheva _____	176
Influence of the ultrasound on the properties of electrodeposited Zn-Co alloys Marija Riđošić, Eva Garcia-Lecina, Asier Salicio Paz, Ljiljana Živković, Jelena Bajat _____	177
Evaluation of Zr and Ti coated stainless steel bipolar plates for polymer electrolyte membrane fuel cells Aida Ghiulnare Pantazi, Sabrina Rosoiu, Eduard Grigore, Marius Enachescu, Liana Anicai _____	178
Electrochemical and morphological investigations of poly(3,4-ethylenedioxyppirrol) films Krisztina J. Szekeres, Mária Ujvári, Gyözö G. Láng _____	179
Investigation of the electrodeposition and dissolution of lead dioxide using electrochemical quartz crystal microbalance (EQCM) Balázs Broda, György Inzelt _____	180
Electrodeposition of Ag and Ag composites with carbon nanotubes using novel deep eutectic solvent formulations Sabrina Rosoiu, Aurora Petica, Aida Ghiulnare Pantazi, Marius Enachescu, Teodor Visan, Liana Anicai _____	181
On the use of scanning Kelvin probe for the <i>in situ</i> assessment of the delamination of adhesively bonded joints Barbara Priscila Andreon, Barbara Luiza Guenther, Welchy Leite Cavalcanti, Peter Plagemann, Lucio Colombi Ciacchi _____	182
Characterization of cobalt(II)-4-nitrocatechol and cobalt(II)-humic acid complexes in aqueous solution Anđela Bačinić, Marina Mlakar _____	183
Investigation of formation and stability of V(IV)-EDTA and V(V)-EDTA complexes using Hanging Mercury Drop Electrode Lucija Knežević, Elvira Bura-Nakić _____	184
Determination of surface activity of natural organic matter by using pulsed techniques Saša Marcinek, Dijana Jadreško, Dario Omanović _____	185
Hyphenation of scanning electrochemical microscopy and scanning ion conductance microscopy using photoresist-coated micropipettes Stefan Wert, Timo Raith, Frank-Michael Matysik _____	186

**PLENARY LECTURES**  
**RSE SEE 7**

## Advancement in the electrochemical testing and characterization of power sources

Daria Vladikova, Blagoy Burdin

*Institute of Electrochemistry and Energy Systems – BAS, 10 Acad. G. Bonchev St., 1113 Sofia, Bulgaria*  
[d.vladikova@bas.bg](mailto:d.vladikova@bas.bg)

Testing, monitoring and diagnostic of electrochemical power sources (EPS) as batteries and fuel cells is a main tool for their development and optimization. The experimental procedures include numerous steps – from the selection of the active materials and their shaping, to the design of the cell architecture and optimization of the operating conditions. An important moment, which still has no definite solution, is the estimation of degradation rate, durability, state of health, lifetime prediction, as well as monitoring and diagnostics during operation. This work aims at presenting some advancements in the methodological approaches for testing, monitoring and diagnostics of electrochemical power sources with emphasis on electrochemical impedance spectroscopy (EIS). Although the selected examples are extracted mainly from solid oxide fuel cell (SOFC) studies, the discussed algorithms are applicable for different EPS.

The success of the impedance-based study starts with the selection of appropriate experimental conditions and test cell architecture which may increase the information capability. This will be demonstrated on “in situ” measurements of the initial reduction and redox cycling of SOFC anode and on registration of water formation in an innovative design of SOFC.

The unique advantage of EIS is the measurement of processes with different time-constants which ensures the possibility to separate and characterize in a single measurement the different steps involved in a complex process. However, since impedance does not measure a physical property, an identification procedure for data analysis is used based on preliminary selected working hypotheses. For EPS, which are complex electrochemical systems, the knowledge-based theoretical models are an exception, rather than a rule. This basic problem of the parametric identification can be bypassed applying the DIA technique. It works with the same initial set of data and provides both structural and parametric identification. The technique is illustrated on examples of oxygen reduction studies in SOFC.

In principle EIS is a very powerful tool and ensures deeper insight into the object under study, however, in a single working point, while the current-voltage ( $i$ - $V$ ) characteristics present integral picture of the EPS (cell, stack) for a given state. The combination of impedance and  $i$ - $V$  measurements gives a new approach for durability studies of EPS, offering increased sensitivity in evaluation of the degradation rate and a tool for assessment of the state of health (SoH). The developed method, named Differential Resistance Analysis (DRA), operates with the Differential Resistance  $R_d$  (the derivative of the voltage in respect to the current). A new characteristic point – the minimum of  $R_d$  is introduced. It reflects the EPS SoH and is recommended for impedance measurements. Examples on long term SOFC tests are presented.

This talk is given in memory of Prof. Zdravko Stoynov, for his significant achievements in the development of Electrochemical Impedance Spectroscopy and strong support in the establishment of the Regional Symposium on Electrochemistry of South-East Europe.

*Acknowledgements:* This work is supported by the Bulgarian Ministry of Education and Science under the National Research Programme E+: Low Carbon Energy for the Transport and Households, grant agreement D01-214/2018 and the National Roadmap for Research Infrastructure (2017-2023): Research Infrastructure Energy Storage and Hydrogen Energetics NI SEVE, grant agreement D01-160/28.08.18

## Reaction and transport mechanisms in lithium-sulfur batteries

Miran Gaberšček<sup>1,2</sup>, Sara Drvarič Talian<sup>1</sup>, Jože Moškon<sup>1</sup>, Jan Bitenc<sup>1</sup>, Alen Vižintin<sup>1</sup>, Robert Dominko<sup>1</sup>

<sup>1</sup>National Institute of Chemistry, Ljubljana, Slovenia

<sup>2</sup>Faculty of Chemistry and Chemical Technology, University of Ljubljana, Slovenia

The lithium-sulfur battery is one of the most researched post lithium-ion systems. Still, the high theoretical capacity of 1672 mAh g<sup>-1</sup> is difficult to attain in practice. Additionally, its power density lags behind that of the Li-ion technology and other alternatives. We will present extensive experimental work starting with a short review of innovative “in-situ” methods that enable unique insight into the processes taking place during charge and discharge of Li-S system<sup>1</sup>. Then we will show several case studies that focus on individual electrochemical process of interest in all three system components, *i.e.* carbon cathode, metallic lithium anode and electrolyte-soaked separator - and the corresponding interfaces. For example, on the lithium side we will discuss the dynamics of solid electrolyte interface (SEI) during charge-discharge and present a suitable model to explain the effects of SEI on electrochemistry<sup>2</sup>. On the cathode side we will try to identify reasons for performance limitation of the Li-S system. We will show, contrary to expectations, that the solid products released during discharge of Li-S battery hardly block the main electrochemical reaction(s). Based on the use of cells with special design, we will determine and comment on the values of the main transport-reaction parameters (rate constants, diffusion coefficients)<sup>3</sup>. Finally, we will discuss how the new findings can be exploited to improve the performance of the next generation of Li-S batteries.

### References

1. A. Vižintin et al., *Nature Communications* **9** (2018) Article number: 661.
2. M. Adamič et al., *Journal of the Electrochemical Society* **166** (2019) A5045-A5053.
3. S. Drvarič Talian, *ACS applied materials & interfaces* **9** (2017) 29760-29770.

## Electrolytic iron production from alkaline suspension of solid oxides: compared cases of hematite, iron ores and iron-containing processing waste

Francois Lapicque

*Reactions and Chemical Engineering Laboratory, CNRS-Univ. Lorraine, Nancy, France*

The presentation covers two main domains of activity : (i) development of an alternative process for iron process by electroreduction of hematite particles being an alternative of the conventional CO<sub>2</sub>-emitting process of iron/steel production from iron oxides by chemical reduction of carbon, (ii) recovery of iron from “red muds”, the waste produced by treatment of bauxite by concentrated hot alkaline solutions after Bayer process: these muds form currently huge “schlamm” of heavy alkaline suspensions of trivalent iron. Both topics are aimed at (i) producing iron without limited CO<sub>2</sub> emissions and lower energy consumption, (ii) beneficiation of hazardous, cumbersome waste.

For the first route the year-long collaboration with ArcelorMittal and with active support of French governmental organisms, allowed to develop a process –currently at the industrial pilot scale – for iron production by electroreduction of hematite particles suspended in concentrated alkaline media at high temperature: it was shown that the reduction of the scarcely soluble solid is only possible upon mechanical contact between the cathode and the particles. In view to more practical applications, the case of iron ores *e.g.* Carajas or Tubarao, which contain various impurities at levels depending on their origin, was investigated: attempts in correlating the compared deposition performance in terms of current density and faradaic yield for hematite and various ores are presented: surface phenomena in addition to particle size distribution of the solid actually play a significant role in the deposition performance. This has an impact on the design of the unit operations for preparation of suitable, reactive ores from the raw materials extracted in iron mines, and has to be accounted for in the design of the overall metallurgical process.

The second case studied with Extractive Company is the possible beneficiation of the red muds, whose content of iron species can exceed 50 %. A favourable aspect of this waste for possible reduction of iron oxide to iron is the alkaline nature of the suspensions. However, whereas the electroreduction of hematite can be carried out at 0.1 A/cm<sup>2</sup> with current efficiency over 85 %, that with iron muds was found to stagnate at 20%. Routes for improvement for the deposition are presented, in particular to better understand the effects of partly dissolved impurities, particle interaction and grain size are discussed. As a matter of fact, in both cases treated, the behaviour of iron-rich ores or waste cannot be mimicked by pure hematite suspended in the alkaline liquor containing the dissolved impurities of the solids to be converted.

## ***In-situ* electrochemical, microscopic and spectroscopic studies of local corrosion and buried metal-polymer interfaces**

J.M.C. Mol

*Delft University of Technology, Department of Materials Science and Engineering,  
Corrosion Technology and Electrochemistry, 2628CD Delft, The Netherlands*

The type, concentration, clustering and distribution of alloying elements in metal alloys largely determine the mechanical and corrosion properties of the resulting alloy. The differences in electrochemical properties of microstructural features in metal alloy surfaces are commonly the triggering and controlling factors in their localized corrosion behaviour. However, to date we still struggle to fully bridge the gap between microstructural and electrochemical characterization at the (sub)micron scale.

To prevent (local) corrosion of metals, the application of organic coatings is one of the most common corrosion protection strategies. The initial adhesion and resistance against delamination of organic coatings on metal surfaces highly depend on the polymer/oxide/metal interfacial chemistry. While the type of bonding contributes to the strength of adhesion, the nature of the interface depends on both functionality present in the organic molecules of the coating and the nature of the oxide film *e.g.* hydration, hydroxyl content, oxide thickness, surface morphology and chemical composition. However, studying the bonding properties of the polymeric coating to the metal (oxide) surface is experimentally difficult, because the interface is hard to be reached by analytical techniques due to the relatively high thickness of the polymer coatings.

This presentation will focus on the research opportunities and challenges we face for local, combined and in-situ analysis by advanced electrochemical, microscopic and spectroscopic techniques to study corrosion (inhibition) and buried metal-coating interfaces.

**PLENARY LECTURE**  
**8<sup>th</sup> Kurt Schwabe Symposium**

## Gas sensing technologies in combustion: A comprehensive review

Pavel Shuk<sup>1</sup>, Hans-Ulrich Guth<sup>2</sup>, Chad McGuire<sup>1</sup>

<sup>1</sup>Rosemount Measurement and Analytical, Emerson Automation Solution, 6021 Innovation Blvd, Shakopee, MN 55379-4676, USA, [Pavel.Shuk@Emerson.com](mailto:Pavel.Shuk@Emerson.com)

<sup>2</sup>Kurt Schwabe Institute for Measuring and Sensor Technology, Kurt-Schwabe-4, 04736 Waldheim, Germany

In the regular combustion process, hydrocarbon fuel would react with oxygen (O<sub>2</sub>) producing primarily carbon dioxide and water with traces of other gases, *e.g.*, sulfur dioxide and nitrogen oxides. The oxygen is measured to optimize the combustion process efficiency and to control the product formation and quality [1-2]. Combustion control is mostly accomplished with O<sub>2</sub> measurement alone and an improved combustion efficiency can be achieved with the concurrent measurement of carbon monoxide (CO) ppm level and ~1-6 % O<sub>2</sub> concentration depending on the fuel type [3]. CO monitoring in combustion process offers a new opportunity for safe flame operation with CO being as a marker of incomplete fuel-rich combustion or indicating burner malfunction [4]. At combustion startup an extra methane measurement implemented in combustion analyzer would be an extra safety feature for the combustion diagnostics and control [5].

The two most comprehensive oxygen gas sensing technologies, zirconia potentiometric and tunable diode laser spectroscopy (TDLS) are dominating the most of in-situ and extractive combustion applications. Zirconia potentiometric oxygen gas sensing technology invented in 1961 by Möbius and Peters [6] was rapidly accepted in the power industry. All industrial zirconia oxygen sensors are based on an electrochemical cell with oxygen ion conducting yttrium stabilized zirconia (YSZ) solid electrolyte and two platinum-based electrodes printed and sintered on the opposite sides of the zirconia ceramic and exposed to the process and reference gases. By using fixed oxygen partial pressure on the reference electrode, *e.g.*, air with  $p(\text{O}_2) = 2.1 \cdot 10^4$  Pa, the sensor signal of the thermally balanced oxygen sensor will be depending only on sensor temperature and O<sub>2</sub> concentration in process. Tunable diode and quantum cascade laser spectroscopies (QCLS) utilizing semiconductor lasers to detect in infrared range (IR) a variety of gases, including O<sub>2</sub>, CO and CH<sub>4</sub>, in combustion process have become established methods for non-intrusive measurements in combustion environment [4]. TDLS is highly distinguishing from the conventional process photometry by the ability of the laser to be scanned across very narrow oxygen absorption peaks.

There are three comprehensive CO gas sensing technologies implemented in combustion analyzers on the market: calorimetric catalytic, mixed potential electrochemical and QCLS/TDLS [3-4]. Calorimetric CO-sensors were developed by analytical corporations utilizing selective combustion reaction on catalyst with implemented resistance temperature detector (RTD) for the released heat measurements. The catalyst material in calorimetric CO-sensor was initially based on *Hopcalite*<sup>®</sup> and was replaced by more reliable platinum group catalyst. Mixed-potential gas sensing technology employing oxygen ion conducting zirconia solid electrolyte and two different activity electrodes was proposed for the detection of combustible gases. Unfortunately, mixed potential CO sensor signal is not linearly depending on CO concentration and cross-interference to O<sub>2</sub>, SO<sub>2</sub> and NO<sub>x</sub> would be highly affecting CO-sensor performance [3]. The IR absorption spectrum of CO is providing CO identification at 1.57 $\mu$ , 2.33 $\mu$  (TDLS) or 4.6 $\mu$  (QCLS) and measurements in a wide concentration range down to ~0.5 ppm CO or even ~10ppb CO (QCLS) as a detection limit.

From four available major methane gas sensing technologies, only two, catalytic calorimetric and TDLS/QCLS have found so far practical application in instrumentation on the combustion market being quite reliable and accurate (~2...5% error) in extractive or across the stack in-situ measurements [5].

### References

1. P. Shuk, *Technisches Messen*, Vol 77 (2010), pp. 19-23
2. P. Shuk, *Sensors for Everyday Life, Smart Sensors, Measurement and Instrumentation*, Mukhopadhyay et al. (eds.), Vol 23 (2017), pp. 81-107
3. P. Shuk, C. McGuire, *Sensors & Transducers*, Vol 217 (2017), pp. 1-13
4. R. K. Hanson, *Proceedings of the Combustion Institute*, Vol 33 (2011), pp. 1-40
5. P. Shuk, C. McGuire and E. Brosha, *Sensors & Transducers*, Vol 229 (2019), pp. 1-10
6. H. Peters, H.-H. Möbius, DD-Patent 21673 (1961, Germ)

**KEYNOTE LECTURES**  
**RSE SEE 7**

## The effects of time-variance on impedance measurements: examples on a corroding electrode and a battery cell

Nicolas Murer, Jean-Paul Diard, Bogdan Petrescu

Bio-Logic SAS, 4 Rue de Vaucanson, 38170 Seyssinet-Pariset, France

[nicolas.murer@bio-logic.net](mailto:nicolas.murer@bio-logic.net)

For valid Electrochemical Impedance Spectroscopy (EIS) measurements, the system under investigation should be linear, stable, causal and stationary [1,2]. In this paper, stationarity comprises steady-state and time-invariance. Steady-state is the state of a system after its transient state. Time-variance is the property of a system whose parameters are changing with time. Sometimes the two properties are difficult to separate. The most classical use of EIS in corrosion is for the determination of the polarization resistance  $R_p$  using the Stern-Geary or Wagner-Traud relationship [3-7]. A corroding system is a non-stationary system specifically after the first instant of immersion. The parameters change can greatly affect the impedance data especially at lower frequencies. The effect of the change of polarization resistance on impedance is simulated and validated by experimental data (Figs. 1a and b). In the field of batteries, EIS measurements during continuous charge or discharge, or *in operando*, are used to inspect a battery under operation [8, 9]. The problem in this case is to know which impedance data can be considered valid, or better said, at which frequency should my data be considered as erroneous because of the time-variance of the system? For this matter an indicator named Non-Stationary Distortion (NSD) is introduced.

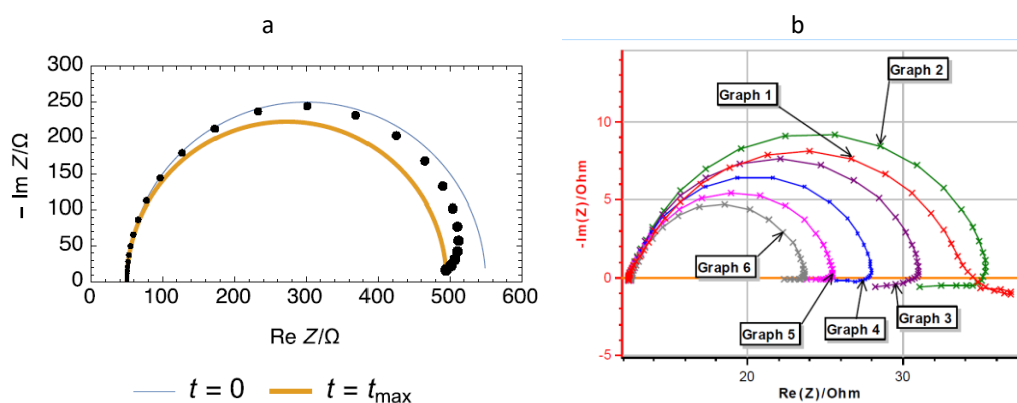

Figure 1: a) Instantaneous Nyquist impedance diagrams ( $t = 0$  and  $t = t_{max}$ ) of the circuit  $R1+R2(t)/C2$  ( $R1 = 50 \Omega$ ,  $R2_0 = 500 \Omega$ ,  $k = 10^{-5} \Omega s^{-2}$ ,  $C2 = 2 \times 10^{-2} F$ ) and simulation of the measured diagram ( $\bullet$ ) when  $R2$  is decreasing with time. The dot size increases with increasing time. The frequency sweep is performed from  $f_{max} \rightarrow f_{min}$  with  $f_{max} = 10 \text{ Hz}$  and  $f_{min} = 10^{-3} \text{ Hz}$ . b) Experimental impedance graphs obtained on a steel sample right after immersion. Each graph was performed one after the other.

### References

1. M. Urquidi-Macdonald, D. Macdonald, *Electrochim. Acta* **35** (1990) 1559 ([https://doi.org/10.1016/0013-4686\(90\)80010-L](https://doi.org/10.1016/0013-4686(90)80010-L))
2. K. Darowicki, *J. Electroanal. Chem.* **486** (2000) 101 ([https://doi.org/10.1016/S0022-0728\(00\)00110-8](https://doi.org/10.1016/S0022-0728(00)00110-8))
3. C. Wagner and W. Traud, *Z. Elektrochem.* **44** (1938) 391 (<https://doi.org/10.1002/bbpc.19380440702>)
4. M. Stern and A. L. Geary, *J. Electrochem. Soc.* **104** (1957) 56 (<https://doi.org/10.1149/1.2428496>)
5. I. Epelboin, M. Keddam, and H. Takenouti *J. Appl. Electrochem.* **2** (1972) 71 (<https://doi.org/10.1007/BF00615194>)
6. F. Mansfeld in *Advances in corrosion science and technology* M. G. Fontana et al. (Eds.), (Plenum Press, New York, 1976) 163 (<https://doi.org/10.1007/978-1-4615-8255-7>)
7. C. Gabrielli, M. Keddam, H. Takenouti in *Treatise on materials science and technology; Corrosion: aqueous processes and passive films*, J. C. Scully ed., (Academic Press Inc., London, 1983) 395 (<https://doi.org/10.1016/B978-0-12-633670-2.50012-7>)
8. Z.B. Stoynov, B.S. Savova-Stoynov, T. Kossev, *J. Power Sources* **30** (1990) 275 ([https://doi.org/10.1016/0378-7753\(93\)80085-4](https://doi.org/10.1016/0378-7753(93)80085-4))
9. M. Itagaki, K. Honda, Y. Hoshi and I. Shitanda, *J. Electroanal. Chem.* **737** (2015) 78 (<https://doi.org/10.1016/j.jelechem.2014.06.004>)

## Computationally driven development of novel electrocatalysts

Igor A. Pašti

*University of Belgrade – Faculty of Physical Chemistry, Studentski trg 12-16, 11158 Belgrade, Serbia*

Growing energy demands of modern society have become reality, which urges for the development of a sustainable and decentralized energy grid. On this path it is necessary to find efficient means for energy conversion and storage. Electrochemistry provides possibly the most elegant solutions for this problem, with different power sources which can respond to actual needs of many possible users. Electrochemical capacitors, batteries and fuel cells differ by energy and power density (in many ways being complementary to each others), and nowadays the most frequently used type power sources are batteries. On the other hand, electrocatalysis has the central role in fuel cell technologies, hydrogen economy, and numerous industrial processes. This is owed to a high selectivity, simple control over the reaction rates and easy scale up. One of the biggest problems in electrocatalysis is the fact that most of the reactions which are relevant for the energy conversion applications rely on the catalyst based on platinum and other elements of platinum group, which are very expensive. Hence, in order to bring electrocatalysis-based energy conversion technologies to everyday use one has to tackle this problem. There are two possible ways. One can either reduce the price of the catalyst while maintaining its activity, or increase the activity, which would reduce the amount of the catalyst which has to be used. Standard approach in searching for new electrocatalysts is based on trial-and-error approach. While previous knowledge and experience could guide this search, it can be time-consuming, expensive and, most importantly, unsuccessful. Development of advanced computational techniques, mainly based on Density Functional Theory, enable rational design of new electrocatalytic materials, an approach that has proven its potential. The biggest problems in this approach are connected with the complexity of the electrified interface, something that still misses proper computational framework and requires large simplification of the modelled system. Another problem is multiparametric space containing large number of different parameters related to chemical and physical properties of electrocatalysts and their performance, which has to be drastically reduced. In the present talk we shall overview some of the recent works on the computational driven discovery of new electrocatalytic materials. First, we shall describe the search for new oxygen reduction reaction electrocatalysts [1] which is based on the idea of electrocatalytic descriptor [2]. Next, we shall consider development of novel Pt-free hydrogen evolution reaction (HER) electrocatalyst [3]. For the second case, we shall discuss how different levels of theory can be combined to develop realistic supported HER catalysts and how different strategies can be applied to properly chose the combination of the catalyst and interactive support which boost hydrogen production.

### References

1. I. A. Pašti, N. M. Gavrilov, M. Baljzović, M. Mitrić, S. V. Mentus, *Electrochim. Acta* **114** (2013) 706 (<https://dx.doi.org/10.1016/j.electacta.2013.10.114>)
2. J. K. Nørskov, T. Bligaard, J. Rossmeisl, C. H. Christensen, *Nat. Chem.* **1** (2009) 37 (<https://dx.doi.org/10.1038/nchem.121>)
3. S. J. Gutić, A. S. Dobrota, M. Leetmaa, N. V. Skorodumova, S. V. Mentus, I. A. Pašti, *Phys. Chem. Chem. Phys.* **19** (2017) 13281 (<https://dx.doi.org/10.1039/C7CP01237C>)

## Formation of disperse deposits by electrolysis: morphology, structure and mechanism

Nebojša D. Nikolić

*ICTM-Department of Electrochemistry, University of Belgrade, Njegoševa 12, Belgrade, Serbia*  
[nnikolic@tmf.bg.ac.rs](mailto:nnikolic@tmf.bg.ac.rs)

The disperse (irregular or powder) deposits can be obtained by both electrolysis from aqueous electrolytes and molten salt electrolysis [1]. The typical disperse forms obtained by electrodeposition processes are: dendrites, flakes, fibrous, spongy, nanowires, crystals of regular or irregular shape, cauliflower-like forms, etc. The shape of electrolytically produced forms does not depend only on the regime and conditions of electrolysis, such as the kind and composition of electrolytes, temperature of electrolysis, the type of cathode, stirring of electrolytes, the addition of specific substances known as additives, etc. but to also the nature of metals [1]. The both, constant (potentiostatic and galvanostatic) and periodically changing (pulsating overpotential (PO), pulsating current (PC) and reversing current (RC)) regimes are used for electrolytic production of disperse forms. Regarding the nature of metals, metals are classified into three groups: *normal* (metals, such as Pb, Sn, Cd, Ag (basic electrolytes) and Zn, characterized by the high values of the exchange current density ( $j_0 > 1 \text{ A dm}^{-2}$ ) and overpotential for hydrogen discharge, and the low melting point, *intermediate* (metals, such as Cu, Au and Ag (complex electrolytes), characterized by moderate melting points, medium exchange current densities ( $j_0$  in the interval from  $10^{-2}$  to  $1 \text{ A dm}^{-2}$ ) and lower hydrogen overpotentials, and *inert* (metals, such as Fe, Co, Ni, Mn, Cr and Pt, characterized by high melting points, low exchange current densities ( $10^{-2} < j_0 < 10^{-12} \text{ A dm}^{-2}$ ) and very low hydrogen overpotentials) metals [2].

Morphology of disperse forms is strictly associated with the affiliation to the determined group of metals. For example, crystals of regular and irregular shapes and wires at sub-micrometer or nanometer scale are usually formed by electrodeposition of so-called *normal* metals. The cauliflower-like particles are formed in conditions of vigorous hydrogen evolution as parallel reaction to metal electrolysis, and they are characteristics of metals from the groups of *intermediate* and *inert* metals. The spongy particles are the typical characteristic of the *inert* metals. The shape of dendritic forms also depends on the affiliation to the determined group of metals. The needle-like and the 2D (two dimensional) fern-like dendrites are formed by electrodeposition of the *normal* metals. On the other hand, the very branchy 3D (three dimensional) pine-like dendrites constructed from approximately spherical grains are characteristic of electrodeposition of both the *intermediate* and the *inert* metals. The very long MgO/Mg(OH)<sub>2</sub> needles, often grouped into the flower-like aggregates, are formed by molten salt electrolysis [3].

Also, there is a strong correlation between morphology of disperse forms and their crystal structure. The needle-like and the 2D fern-like dendrites of Pb and Ag show (111) preferred orientation, while crystallites in approximately spherical grains constructing the 3D pine-like dendrites of Ag (complex electrolytes) and Cu, cauliflower-like particles of Cu and spongy-like particles of Ni were mainly random oriented.

The general theory of disperse deposits formation [1] can be applied to explain mechanism of formation of majority of above mentioned disperse forms, such as dendrites, needles or wires, the growth of crystals of various shape, fibrous, etc. Formation of the cauliflower-like (Cu) and the spongy-like (Ni) particles in conditions of vigorous hydrogen evolution can be explained by the concept of "effective overpotential" [1,4]. The cauliflower-like and the spongy-like forms formed around holes formed from detached hydrogen bubbles represent a constructive element of the honeycomb-like structures, that is the typical disperse form obtained by electrolysis in conditions of vigorous hydrogen evolution.

### References

1. K. I. Popov, S. S. Djokić, N. D. Nikolić, V. D. Jović, *Morphology of Electrochemically and Chemically Deposited Metals*, Springer International Publishing, 2016.
2. R. Winand, *Electrochim. Acta* **39** (1994) 1091 ([http://dx.doi.org/10.1016/0013-4686\(94\)E0023-S](http://dx.doi.org/10.1016/0013-4686(94)E0023-S)).
3. V. S. Cvetković, N. M. Vukićević, N. D. Nikolić, G. Branković, T. S. Barudžija, J. N. Jovičević, *Electrochim. Acta* **268** (2018) 494 (<http://dx.doi.org/10.1016/j.electacta.2018.02.121>).
4. N. D. Nikolić, K. I. Popov, L. J. Pavlović, M. G. Pavlović, *J. Electroanal. Chem.* **588** (2006) 88 (<http://dx.doi.org/10.1016/j.jelechem.2005.12.006>).

## Molecular modeling of corrosion inhibitors: a search for physically sound descriptors

Anton Kokalj, Ingrid Milošev

*Department of Physical and Organic Chemistry, Jožef Stefan Institute, Jamova 39, 1000 Ljubljana, Slovenia*

Molecular modeling based on the use of DFT methods has become very fashionable for exploring new potential corrosion inhibitors [1]. However, the most proliferating approach—which relies on the correlation between calculated molecular electronic parameters and experimentally measured inhibition efficiency, typically obtained on a very small set of similar molecules—provides little (if any) physical insight into actual inhibition mechanism. In this context, Winkler et al. [2] emphasized that the complexity of corrosion inhibition for real systems is sufficiently complex that robust and reasonably predictive quantitative models can be obtained only via machine learning approaches. However, machine learning approaches yield much lower mechanistic insight compared to computationally intensive physics-based methods, because some of the utilized descriptors are hard to interpret in terms of an inhibition mechanism [2].

For this reason we have approached the issue from the mechanistic perspective and in this presentation we will present our efforts in this direction and the corresponding results. In particular, we have tested many organic molecules as potential corrosion inhibitors for copper and aluminum in NaCl solution by electrochemical methods, whereas interfacial bonding of these inhibitors was investigated by various surface science experimental techniques as well as by molecular modeling utilizing explicit DFT calculations of inhibitor–surface bonding. We aim at integrating high-throughput oriented experimental testing of a large number of corrosion inhibitors with insights provided from more detailed mechanistic analyses (experimental and computational) with the specific objective to identify physically-sound corrosion inhibition descriptors. Even though our explorations revealed many details and few new concepts, a sound physical picture that would explain the relation between molecular characteristics of the inhibitor and its inhibition efficiency still remains elusive — the problem is way harder than we anticipated a decade ago.

This work is done in collaboration with M. Poberžnik, D. Costa, F.U. Renner, D. Crespo, J.M.C. Mol, P. Marcus et al. and is a part of two M.Era-Net projects entitled “*Coin Desc: Corrosion inhibition and dealloying descriptors*” and “*COR\_ID: Design of corrosion resistant coatings targeted for versatile applications*”. The financial support of the project by MESS (Ministry of Education, Science and Sport of Republic of Slovenia), NWO (Nederlandse Organisatie voor Wetenschappelijk Onderzoek), FWO (Research Foundation Flanders), MINECO (Ministry of Economy and Competitiveness), and ANR (The French National Research Agency) is acknowledged.

### References

1. A. Kokalj, D. Costa, Molecular Modeling of Corrosion Inhibitors, in *Reference Module in Chemistry, Molecular Sciences and Chemical Engineering; Encyclopedia of Interfacial Chemistry: Surface Science and Electrochemistry*; Elsevier: Amsterdam, The Netherlands, **Vol. 6.1** (2018) 332–345.
2. D. Winkler, M. Breedon, A.E. Hughes, F.R. Burden, A.S. Barnard, T.G. Harvey, I. Cole, *Green Chem.* **16** (2014) 3349–3357.

## Comparison of the protective properties of fatty acid films prepared by different application methods

Helena Otmačić Ćurković, Ekatarina Kristan Mioč, Zana Hajdari Gretić<sup>1</sup>

Faculty of Chemical Engineering and Technology, University of Zagreb, Marulićev trg 19, 10000 Zagreb, Croatia, [helena.otmacic@fkit.hr](mailto:helena.otmacic@fkit.hr)

<sup>1</sup>Pliva Croatia d.o.o., Zagreb, Croatia

Global efforts in environment protection also require the development of non-toxic technologies in the field of corrosion protection, like development of waterborne coatings or green corrosion inhibitors. In line with that, the corrosion protection by fatty acids seems like an interesting choice for metal protection. Our previous studies showed that films of stearic acid, formed by dip-coating method on the surface of cupronickel alloy provide efficient corrosion protection in chloride media [1,2]. In this work stearic acid films are formed on the surface of cupronickel alloy and stainless steel by three different methods: dip coating, spraying and electrochemical method. Their protective properties are examined by electrochemical methods: polarization measurements and electrochemical impedance spectroscopy. The obtained results show that for all three application techniques a proper choice of film application conditions, such as temperature, duration or surface preparation, results in formation of stearic acid films that efficiently protect both studied alloys. This is also confirmed by SEM studies of protected samples exposed to corrosive medium. Generally, the highest initial corrosion protection is achieved by spray coating method which is attributed to the formation of the thickest protective layer. However, after exposure to corrosive medium protection offered by films, formed by spraying, declines while that of the films formed by dip-coating and especially by electrochemical method remains high.

Besides the electrochemical studies, obtained films are characterized by FTIR and Raman spectroscopy and contact angle measurements. In the case of dip-coating and spraying methods formation of ordered layers of stearic acid is assumed, while in the case of films formed by electrochemical method formation of ordered stearate layers is proposed.

*Acknowledgments:* The research leading to these results has received funding from Croatian Science Foundation under grant agreement 9.01/253.

### References

1. Z. Hajdari Gretić, E. Kristan Mioč, V. Čadež, S. Šegota, H. Otmačić Ćurković, S. Hosseinpour, J. Electrochem. Soc. **163** (2016) C937. (<http://dx.doi.org/10.1149/2.1461614jes>)
2. Z. Hajdari, H. Otmačić Ćurković, V. Čadež, S. Šegota, J. Electrochem. Soc., **163** (2016) C145. (<http://dx.doi.org/10.1149/2.0321605jes>)

## A fifty-years old problem re-visited: the voltammograms of diffusion controlled reactions

Tamás Pajkossy

*Institute of Materials and Environmental Chemistry, Research Centre for Natural Sciences,  
Hungarian Academy of Sciences, Magyar tudósok körútja 2, Budapest, Hungary, H-1117*

[Pajkossy.tamas@ttk.mta.hu](mailto:Pajkossy.tamas@ttk.mta.hu)

A simple procedure is suggested by which cyclic voltammograms, CVs, pertinent to partially diffusion controlled charge transfer reactions can be analyzed. By this procedure, from a set of CVs taken at varied scanrates  $v$ , two scan-rate independent, hysteresis-free functions can be calculated. One of them is the diffusion-free polarization curve,  $j_{inf}(E)$ , the other is the semiintegrated form of the reversible CV,  $M_{rev}(E)$ . First, a linear relationship is derived to connect current and its semiintegral at a given potential for CVs taken with varied scan-rates; then results are shown on testing the above procedure with simulated quasi-reversible CV curves. Simulated CVs, their semiintegrated forms and the transformed curves are shown below.

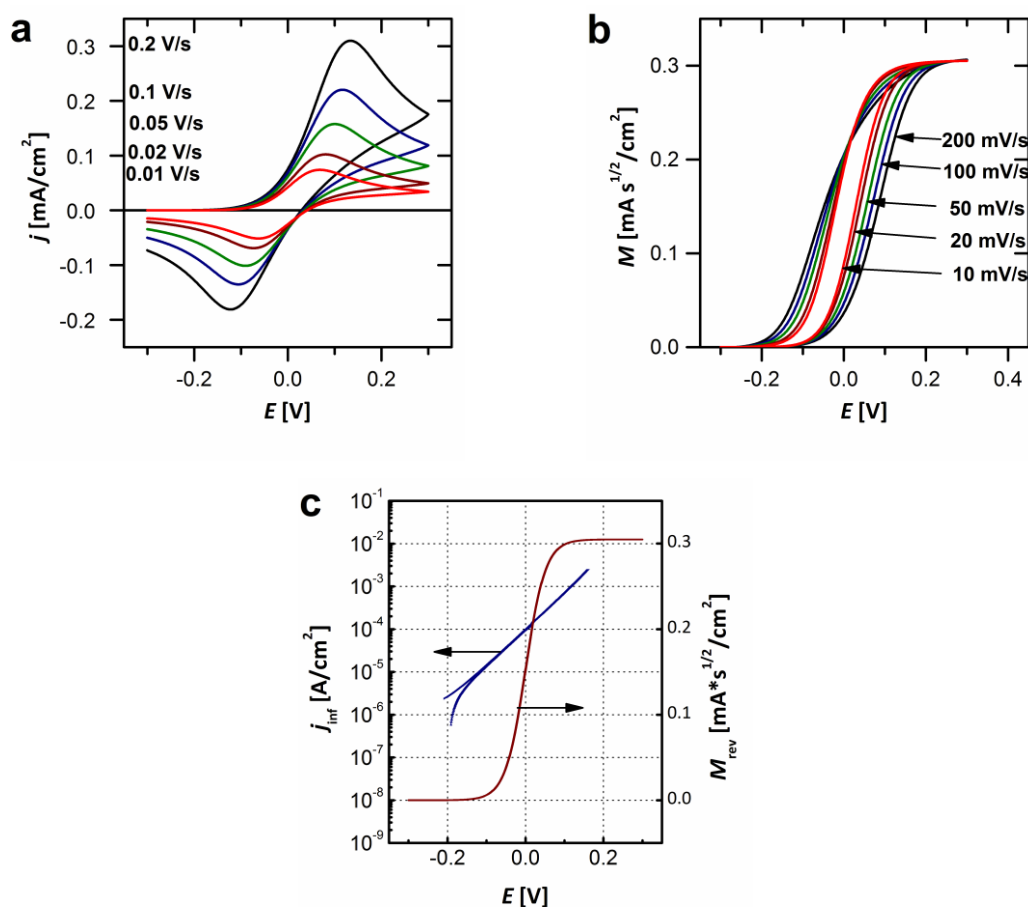

Simulated CVs. Simulation parameters:  $D_{red} = D_{ox} = 10^{-5} \text{ cm}^2/\text{s}$ ,  $C_{red} = 10^{-6} \text{ mol}/\text{cm}^3$ ,  $C_{ox} = 0 \text{ mol}/\text{cm}^3$ ,  $E_0 = 0$ ,  $k_0 = 0.001 \text{ cm}/\text{s}$ ,  $\alpha = 0.5$ ,  $v$ , in  $\text{mV}/\text{s}$  units, as indicated. (b) The semiintegrated CVs. (c) The  $j_{inf}$  and  $M_{rev}(E)$  functions.

### References:

1. T. Pajkossy, Analysis of quasi-reversible cyclic voltammograms: Transformation to scanrate independent form, *Electrochem. Comm.* **90** (2018) 69, doi:10.1016/j.elecom.2018.04.004
2. T. Pajkossy, S. Vesztergom, Analysis of voltammograms of quasi-reversible redox systems: Transformation to potential program invariant form, *Electrochim. Acta* **297** (2019) 1121-1129, doi:10.1016/j.electacta.2018.12.023

## A new environment-sparing method for preparation of nanomaterials applicable in fuel cells and electrolyzers

Jenia Georgieva<sup>1</sup>, N. Dimitrova<sup>1</sup>, S. Sotiropoulos<sup>2</sup>, T. Boiadjieva-Scherzer<sup>3</sup>

<sup>1</sup>Rostislav Kaischew Institute of Physical Chemistry, Bulgarian Academy of Sciences, Sofia, Bulgaria

<sup>2</sup>Department of Chemistry Aristotle University of Thessaloniki, Thessaloniki, Greece

<sup>3</sup>CEST Kompetenzzentrum für elektrochemische Oberflächentechnologie GmbH, Wiener Neustadt, Austria  
[jenia.georgieva@ipc.bas.bg](mailto:jenia.georgieva@ipc.bas.bg)

The oxide-based supports and in particular TiO<sub>2</sub>, is an object of growing interest as a promising candidate for catalyst carbon-free substrate. Different types of nanocatalysts were prepared by a low-temperature, environment-sparing method on TiO<sub>2</sub> powder support. A ternary Pt(Cu)/TiO<sub>2</sub> catalyst was made by photodeposition of Cu on TiO<sub>2</sub> support, followed by galvanic replacement of Cu by Pt from a solution of K<sub>2</sub>PtCl<sub>6</sub> salt (Fig.1). Pt/TiO<sub>2</sub>, IrO<sub>2</sub>/TiO<sub>2</sub> (Fig2) and PtIrO<sub>2</sub>/TiO<sub>2</sub> (Fig.3) catalytic materials were prepared using a direct photodeposition of IrO<sub>2</sub> or/and Pt on TiO<sub>2</sub>. For their characterization energy-dispersive spectrometry, transmission electron microscopy, X-ray photoelectron spectroscopy and X-ray diffraction were applied. The electrochemical (photoelectrochemical) behavior of the catalysts with respect to reactions, typical of fuel cells and electrolyzers (methanol oxidation, oxygen evolution and reduction reactions) was evaluated using cyclic voltammetry, linear sweep voltammetry and chronoamperometry. The inherent and specific mass activity of the as prepared catalysts were assessed and compared to that of commercial Pt/C catalyst and IrO<sub>2</sub> standard. The inherent catalytic activity demonstrated by Pt(Cu)/TiO<sub>2</sub> electrode was higher than the Pt/C catalyst and the specific mass activity was comparable. The improved behavior of the Pt(Cu)/TiO<sub>2</sub> catalyst towards methanol oxidation is associated with effective dispersion and utilization of Pt due to several circumstances. It is prepared by galvanic displacement of photodeposited Cu and galvanic deposition on photo-reduced Ti(III) sites. Due to this, Pt-Cu interaction, as well as the mutual potentiating action of Pt and TiO<sub>2</sub> eases the oxidative detachment of CO poisonous intermediates from Pt (in the dark) and enhance TiO<sub>2</sub> photogenerated electron-hole separation efficiency (under illumination). It was found that the IrO<sub>2</sub>/TiO<sub>2</sub> and PtIrO<sub>2</sub>/TiO<sub>2</sub> catalytic materials possess higher intrinsic and specific mass activity with respect to oxygen evolution reaction than a standard of IrO<sub>2</sub>. Except as an anode, the PtIrO<sub>2</sub>/TiO<sub>2</sub> catalyst can also be used as a cathode for oxygen reduction reaction in fuel cells. The increased catalytic activity of the prepared nanomaterials is attributed to effective dispersion and utilization of Pt and IrO<sub>2</sub> particles, deposited by the used alternative method, as well as the synergy between electrocatalysts and TiO<sub>2</sub> support.

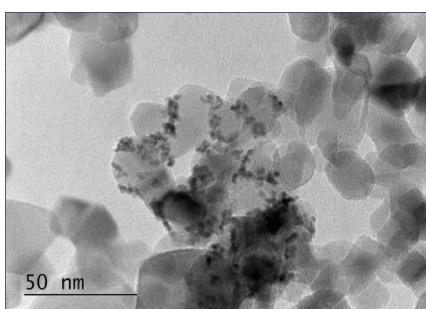

Fig.1 TEM photograph of Pt(Cu)/TiO<sub>2</sub> catalyst

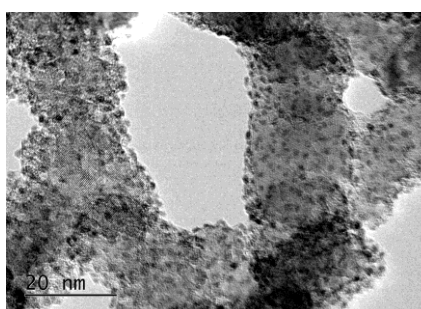

Fig.2 TEM photograph of IrO<sub>2</sub>/TiO<sub>2</sub> catalyst

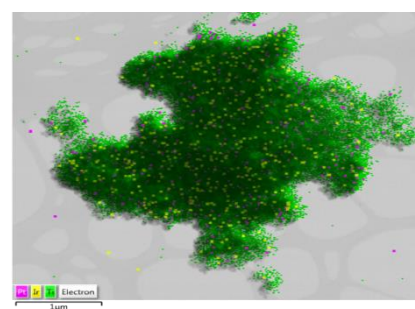

Fig.3 Mapping of Pt/IrO<sub>2</sub>/TiO<sub>2</sub> catalyst

**Acknowledgments:** Financial support of CEST, Austria in the frame of the COMET program is gratefully acknowledged. Bilateral joint research project "Preparation of efficient catalysts for fuel cell, electrolyzers and photo-fuel cells by galvanic replacement" 2016-2019 between Bulgarian Academy of Sciences (BAS) and Aristotle University of Thessaloniki, Greece is also acknowledged.

## Stereoelectrochemistry of reducible calix[4]arenes

Jiří Ludvík, Alan Liška

*J. Heyrovský Institute of Physical Chemistry, The Czech Academy of Sciences, Dolejškova 3,  
Prague 8, 18223, Czech Republic*

[jiri.ludvik@jh-inst.cas.cz](mailto:jiri.ludvik@jh-inst.cas.cz)

Electrochemical experiments are generally source of thermodynamic and kinetic data, analytical results or mechanistic considerations. The present contribution shows that using redox probes and the way of interpretation typical for molecules with multiple redox centers, electrochemistry can offer also information about the actual shape, geometry and rigidity of the studied molecules in the solution, and, consequently, about the electron distribution and delocalization.

This “stereochemical” approach has been demonstrated on the large series of differently substituted oligonitro calix[4]arenes and thia calixarenes [1-5]. This type of macrocycles containing four aromatic units with methylene- or thia- bridges are generally not electrochemically active. Nevertheless, they represent an important skeleton which, after suitable substitution, can serve as a ligand or as a hosting molecule for supramolecular assemblies (host-guest type). In order to enable its electrochemical investigation, it is necessary to introduce one or more redox centers into the parent molecule as “redox probes”. These centers should exhibit clear electrochemical reversible response thus representing “near-to- thermodynamic” data. For that reason nitro groups were selected as the most suitable reducible center for aprotic media, *e.g.* DMF, where they are cathodically reduced by one electron to a stable radical anion.

Due to the presence of one, two, three or four nitro groups (or other redox probes) on various positions of the skeleton, the calixarenes become molecules with multiple redox centers. The idea is that conformation of the calixarene, symmetry of substitution, type of bridging units etc. affect the reduction potentials of each nitro group. As a result, these potentials then reflect not only electronic influence of the substituents due to their inductive and mesomeric (resonance) effects, but also steric features like conformation, geometry, bond or dihedral angles, planarity and movement constrains.

Having a molecule bearing several identical redox centers in various positions, each redox center somehow reflects the above mentioned influences individually at its site, moreover, from the same reasons also the electron communication among the centers (that means certain extent of electron delocalization) can be followed. As a result, evaluation and interpretation of experimental electrochemical data, that means reduction potentials of all centers, can lead among others to the understanding of 3D-arrangement of molecules in solution, their overall shape and dynamic behavior as a consequence of mentioned influences.

### References

3. A. Liška, J. Ludvík, *Current Opinion in Electrochemistry* **8** (2018) 45–51.
- A. Liška, P. Vojtíšek, A.J. Fry, J. Ludvík, *J Org Chem* **78** (2013) 10651–10656.
- A. Liška, M. Rosenkranz, J. Klíma, L. Dunsch, P. Lhoták, J. Ludvík, *Electrochim Acta* **140** (2014) 572–578.
- A. Liška, K. Flídrová, P. Lhoták, J. Ludvík, *Monatshefte für Chemie-Chem Mon* **146** (2015) 857–862.
- A. Liška, P. Lhoták, J. Ludvík, *Electroanalysis* **28** (2016) 2861–2865.

**KEYNOTE LECTURES**  
**8<sup>th</sup> Kurt Schwabe Symposium**

## Novel electrode materials and arrangements for sensing biologically active organic compounds

Jiri Barek

Charles University, Faculty of Science, Department of Analytical Chemistry, UNESCO Laboratory of environmental electrochemistry, Hlavova 8, 128 43 Prague 2, Czech Republic

[Barek@natur.cuni.cz](mailto:Barek@natur.cuni.cz)

Ever increasing demands on voltammetric/amperometric monitoring of trace amounts of biologically active organic compounds in various environmental and/or biological matrices stimulates intensive search for new electrode materials with broader potential window, lower noise, and mechanical stability making them compatible with measuring in flowing systems and above all with higher resistance towards passivation. In this context several novel electrodes frequently applied in our laboratory will be critically compared. Attention will be paid to various forms of amalgam electrodes and bismuth and antimony film and bulk electrodes which are very well suitable for cathodic measurements, to various carbon based electrodes (carbon paste and carbon film electrodes, carbon felt electrodes, carbon porous electrodes), to sputtered film metal electrodes [1] suitable for anodic measurements, and to boron doped diamond electrodes applicable for both cathodic and anodic determinations [2]. Attention will be paid to the application of these non-traditional electrode materials for monitoring of trace amounts of environmental carcinogens, phenols and nitrophenols, priority pollutants, and pesticides. Possibilities of combination of these electrode materials with a preliminary separation and/or preconcentration using liquid-liquid extraction, solid-phase extraction, membrane dialysis and hollow fibre microextraction and miniaturization of used electrodes and their arrangements [3,4] will be briefly discussed.

### References

1. M. Libansky, J. Zima, J. Barek, A. Reznickova, V. Svorcik, H. Dejmekova, Basic electrochemical properties of sputtered gold film electrodes. *Electrochim. Acta* **251**(2017) 452.
2. J. Svitkova, T. Ignat, L. Svorc, J. Labuda, J. Barek, Chemical modification of boron-doped diamond electrodes for applications to biosensors and biosensing. *Crit. Rev. Anal. Chem.* **46** (2016) 248.
3. S. Skalova, L. M. Goncalves, T. Navratil, J. Barek, J. A. Rodrigues, V. Vyskocil, Miniaturized voltammetric cell for cathodic voltammetry making use of an agar membrane. *J. Electroanal. Chem.* **821** (2018) 47.
4. J. Gajdar, J. Barek, M. Fojta, J. Fischer, Micro volume voltammetric determination of 4-nitrophenol in dimethyl sulfoxide at a glassy carbon electrode. *Monatshefte Fur Chemie* **148** (2017) 1639.

## Results achieved fitting to- and using SECM in corrosion experiments

Géza Nagy<sup>1</sup>, Lívia Nagy<sup>1</sup>, András Kiss<sup>1</sup>, Dániel Filotás<sup>1</sup>, Abdelilah Assergine<sup>1</sup>, Ricardo M. Souto<sup>2</sup>

<sup>1</sup>Dept. of General and Phys. Chem., Faculty of Sci., University of Pécs, Ifjúság útja 6, 7624 Pécs, Hungary

<sup>2</sup>Dept. of Chem., Universidad de La Laguna, P.O. Box 456, E-38200 La Laguna, Tenerife, Canary Islands, Spain

[g-nagy@gamma.ttk.pte.hu](mailto:g-nagy@gamma.ttk.pte.hu)

Amperometry was employed as signal forming technique in initial period of scanning electrochemical microscopy (SECM). Soon after the invention, it became widely accepted that this new version of probe microscopy with amperometric detection is a powerful technique that can be employed in obtaining high resolution chemical images, as well as in collecting quantitative information about physicochemical properties of different species or processes; furthermore it can be used as fine tool in forming micro objects.

Introduction of ion selective micro electrodes as measuring tips in practice SECM was an obvious step. It provided new routes for studying fine details of different events, especially details of corrosion processes. It turned up however, several difficulties that needed special care:

- The ion selective electrodes are passive sensors. They do not interact with the solid sample surface. They do not indicate the tip – surface distance.
- The smaller the electrode the higher is its resistance. The response time of the potentiometric circuitry increases by the RC value. Finding safe scanning rate is a challenge.
- The electrode potential – time transience is affected by interfering ion concentration even when the electrode provides high enough selectivity in equilibrium
- The corrosion processes usually generate electric field that disturbs the local concentration measurements.

We have been involved in the research work of improving and using SECM technique for decades. Recently we have been focusing our efforts into studying corrosion processes. In the presentation a few examples will be discussed about our results.

### References:

1. B. R. Horrocks, M. V. Mirkin, D. T. Pierce, A. J. Bard, G. Nagy, K. Tóth, *Anal. Chem.* **65** (1993) 1213-1224
2. Chang Wei, A.J. Bard, I. Kapui, G. Nagy, K. Tóth, *Anal. Chem.* **68** (1996) 2651-2656
3. R.M Souto, A. Kiss, J. Izquierdo. L. Nagy, I. Bitter, G. Nagy, *Electrochem. Commun.* **26** (2013) 25–28
4. D. Filotás, A. Asserghine, L. Nagy, G Nagy, *Electrochem. Commun.* **77** (2017) 62-64
5. D. Filotás, B.M. Fernández-Pérez, A. Kiss, L. Nagy, G. Nagy, R.M. Souto, *J. Electrochem. Soc.* **165** (5) (2018) C1-C8

**ORAL PRESENTATIONS**  
**RSE SEE 7**

# **Batteries and Electrochemical Energy Storage**

## Improved electrochemical performance of lithium titanate anodes with conductive polymer binder

Veniamin Kondratiev, Svetlana Eliseeva, Ekaterina Shkreba, Mikhail Kamenskii, Elena Tolstopjatova  
St. Petersburg State University, 7/9 Universitetskaya nab., St. Petersburg, 199034, Russian Federation  
[vkondratiev@mail.ru](mailto:vkondratiev@mail.ru)

The electrodes of lithium ion batteries are usually composite materials consisting of active component, conductive additives and binder. The electrochemical performance of such composite materials depends strongly upon the size of active material and the distribution into the media of conductive and binder additives. Recently, it was shown that the choice of binder is crucial factor of enhancement of specific capacity and high rate performance of LIB electrodes.

In this work, we present a simple and cost-effective approach to fabricate  $\text{Li}_4\text{Ti}_5\text{O}_{12}$  electrodes with enhanced functional properties by using eco-friendly conductive binder, which is an alternative to fluorine-containing binders. The varied of compositions of new binder consisting of a combination of conducting polymer poly-3,4-ethylenedioxythiophene:polystyrene sulfonate (PEDOT:PSS) dispersion and carboxymethylcellulose (CMC) were proposed as component of  $\text{Li}_4\text{Ti}_5\text{O}_{12}$ -based negative electrode and the results are compared with conventional polyvinylidene fluoride (PVDF) binder. Morphology and structure of the composite materials were investigated by X-ray diffraction, scanning electron microscopy and EDX analysis.

Electrochemical characterization was performed by galvanostatic charge-discharge experiments, cyclic voltammetry and impedance spectroscopy. The electrode with optimized composition of PEDOT:PSS/CMC binder has superior properties, in particular increased specific capacity and improved C-rate performance during charge-discharge. Used instead of PVDF the specific capacity is increased by up to 14% ( $157 \text{ mAh g}^{-1}$  at 0.2C, normalized to total electrode mass). The advantage of modified electrodes becomes more noticeable with the increase of charge current density, where the capacity values  $134 \text{ mAh}\cdot\text{g}^{-1}$  (at 10C),  $110 \text{ mAh}\cdot\text{g}^{-1}$  (at 20C), and  $63 \text{ mAh}\cdot\text{g}^{-1}$  (at 30C) are remarkably better than for electrode with conventional PVDF binder. We have tested a button cell composed of a positive  $\text{LiFe}_{0.4}\text{Mn}_{0.6}\text{PO}_4$  electrode, a negative  $\text{Li}_4\text{Ti}_5\text{O}_{12}$  with the same conducting polymer binder for both electrodes. The mass loading ratio of  $\text{LiFe}_{0.4}\text{Mn}_{0.6}\text{PO}_4$  positive electrode and  $\text{Li}_4\text{Ti}_5\text{O}_{12}$  negative electrode was calculated before battery assembly to be 0.879. The discharge capacity and cycle life stability of battery were tested. The good cycling performance observed with capacity fading of only 16 % over 1000 cycles is remarkable.

To uncover the origin of positive influence of conductive binder on the electrochemical properties of  $\text{Li}_4\text{Ti}_5\text{O}_{12}$  material the study of kinetics of  $\text{Li}^+$  intercalation/de-intercalation processes was carried out by electrochemical impedance spectroscopy. It was found that the  $\text{Li}_4\text{Ti}_5\text{O}_{12}$ /PEDOT:PSS/CMC electrodes demonstrate the smallest charge transfer resistance and the highest apparent diffusion coefficients of lithium ions, which favor enhanced kinetics of charge-discharge processes. The relationship between the electronic and ionic conduction and the electrochemical performance of composite electrode materials will be discussed.

*Acknowledgments:* Financial support from Saint Petersburg State University (grant № 26455158) is gratefully acknowledged. The authors would like to thank the Center for X-ray Diffraction Methods and the Interdisciplinary Center for Nanotechnology Research park of Saint Petersburg State University.

## Status, challenges and possible solutions for rechargeable zinc-air flow batteries

Birgit Pichler<sup>1</sup>, Bernhard Gollas<sup>2</sup>, Viktor Hacker<sup>1</sup>

<sup>1</sup>Institute of Chemical Engineering & Environmental Technology, TU Graz, Inffeldg. 25C, 8010 Graz, Austria.

<sup>2</sup>Institute for Chemistry and Technology of Materials, TU Graz, Stremayrgasse 9, 8010 Graz, Austria.

A significant reduction in greenhouse gas emissions can only be achieved by increasing the installation capacities of wind and solar power systems. The intermittent and fluctuating power production by the renewable energies requires electrical energy storage systems to stabilize the electricity grid. Large-scale electrochemical energy storage technologies, such as flow batteries (all vanadium, zinc-bromine) or sodium-sulphur batteries, have to meet the challenging long-term cost targets (e.g. DoE < 150 \$ / kWh) [1]. The rechargeable zinc-air flow battery represents a promising storage technology with low environmental impact and compact system design. It uses the abundant and inexpensive metal zinc as storing material. The second reactant – oxygen- is withdrawn from the surrounding air (Figure 1, left).

The main challenges of this system are the inhomogeneous zinc deposition during charging leading to short circuiting by dendrite formation and loss of active material as well as the high overpotentials and low stability of the bifunctional air electrode. Overall these issues accumulate in limited lifetime, deteriorating cycle stability and low energy efficiency, which prevents the application of the zinc-air battery as stationary energy storage system [2,3].

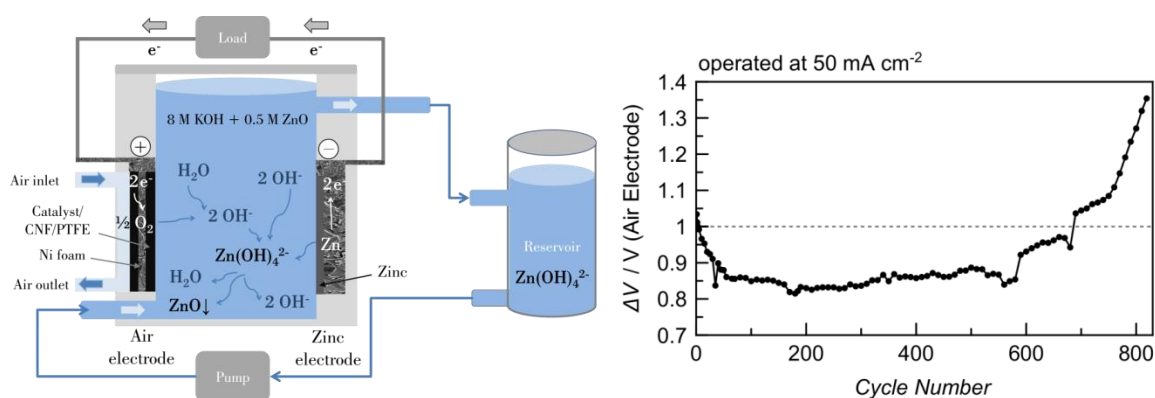

Figure 1: Left – Schematic of a zinc-air flow cell with only one external reservoir; right – results of a long-term cyclization measurement of a bifunctional air electrode showing the potential difference between charge and discharge ( $\Delta V$ ) vs. the cycle number [2].

Results of the international research project LUZIFLOW as well as strategies for improving the long-term stability of the bifunctional air and the zinc electrodes at practicable charge/discharge current densities of up to 50 mA cm<sup>-2</sup> (Figure 1, right) are discussed in the presentation. Stable cycling potentials with electrode areas of 60 cm<sup>2</sup> are demonstrated in lab-scale flow batteries [2]. In addition, the feasibility of the pulse interrupt charging method, which is a preferential method for obtaining dendrite-free zinc deposits, is successfully evaluated in unit zinc-air cell operation [3,4].

### References

1. A. Khor, P. Leung, M.R. Mohamed, C. Flox, Q. Xu, L. An, R.G.A. Wills, J.R. Morante, A.A. Shah, *Mater. Today Energy*. **8** (2018) 80–108. <https://doi.org/10.1016/j.mtener.2017.12.012>.
2. B. Pichler, K. Mayer, V. Hacker, *Batter. Supercaps.* (2018) 1–10. <https://doi.org/10.1002/batt.201800094>.
3. B. Pichler, B.S. Berner, N. Rauch, C. Zelger, H.-J. Pauling, B. Gollas, V. Hacker, *J. Appl. Electrochem.* **48** (2018) 1043–1056. <https://doi.org/10.1007/s10800-018-1233-z>.
4. B. Pichler, S. Weinberger, L. Reščec, I. Grimmer, F. Gebetsroither, B. Bitschnau, V. Hacker, *Electrochim. Acta*. **251** (2017) 488–497. <https://doi.org/10.1016/j.electacta.2017.08.128>.

## On the validity of using the diffusion coefficient in characterization of charge transfer reactions in systems with a solid-phase reagent

Viacheslav Barsukov, Volodymyr Khomenko, Oksana Butenko

*Department of Electrochemical Power Engineering and Chemistry*

*Kyiv National University of Technologies and Design, 2 Nemyrovych-Danchenka str., Kyiv 01011 Ukraine*

[v-barsukov@i.ua](mailto:v-barsukov@i.ua)

The electrochemical literature dealing with the charge transfer reactions in systems containing a solid-phase reagent often contains assumptions about the value of diffusion coefficient,  $D$ . However, the spread of  $D$  values for similar electrochemical systems reported by different researchers using different methods is often too big and commonly ranges over several orders of magnitude. For example, as it was shown by our analysis of literary sources, the spread of  $D$  values for the proton in the following classical solid-phase reaction in a Nickel-Oxide electrode is as minimum 12 orders:



As it was shown by prof. A. V. Churikov (2013, Saratov State University), the spread of  $D$  values is as minimum 10 orders for lithium ion intercalation-deintercalation in different graphite-carbon active materials:



There is no consistency in the reported descriptions of solid-phase processes in a variety of layered cathode materials for lithium batteries either. Moreover, even if  $D$  is measured in the same material by the same author using the same technique, its value changes by several orders of magnitude during the charge-discharge reaction. So, strictly speaking,  $D$  cannot be considered a constant coefficient as the diffusion theory suggests.

In our opinion, the main reason for the variance discussed is that most of the solid-phase reactions like (1) and (2) involving charged particles, proceed through a migration mechanism but not through a diffusion mechanism. The driving force for these reactions is not the difference in concentrations but the difference in potentials. Therefore, taking diffusion approaches and parameters to these reactions is not sufficiently justified. In many cases, the diffusion processes, whose rate in solid phase is typically very low, are negligible compared with the migration processes in real systems with a solid-phase component. In such systems, a considerable contribution to the charge-transfer is made by the grain microstructure of the active-material, its defectiveness and porosity, the presence of interlayer water (for aqueous systems) and interlayer electrolyte (for non-aqueous systems).

In particular, the content of interlayer water in the nickel hydroxide crystal is an important contributing factor to the NOE performance, whereas the proton transfer is most likely to occur through migration via the interlayer water by a Grotthuss mechanism rather than through the diffusion in the solid phase. Similarly, lithium transfer in carbon and most layered cathode materials proceeds at a much higher migration rate in the presence of a lithium-containing electrolyte in the pores (cracks) of active-material crystals.

A logical question thus arises: to which extent is it appropriate to use the assumptions about diffusion and the  $D$  coefficient for the processes having mainly migration nature? Formally,  $D$  can be connected to mobility coefficient  $\mu$  by the well-known Einstein equation  $D_{\text{eff}} = kT\mu/e$ , where  $kT$  is Boltzmann factor.

Yet, even in this formalization, the EFFICIENT diffusion coefficient  $D_{\text{eff}}$  could at best be discussed not to distort the ideas of charge-transfer migration mechanisms in the systems containing a solid-phase reagent.

## Introduction of differential resistance analysis in battery testing

Blagoy Burdin, Dimitar Bojchev, Daria Vladikova

*Institute of Electrochemistry and Energy Systems - Bulgarian Academy of Sciences,*

*10 Acad. G. Bonchev St., 1113 Sofia, Bulgaria*

[b.burdin@iees.bas.bg](mailto:b.burdin@iees.bas.bg)

The State of Health (SoH) indicates the general condition of a battery state between the beginning and end of life and represents a complex assessment between parameters such as internal resistance, capacity, charge acceptance, voltage, self-discharge, etc. This work presents the first results of using the Differential Resistance Analysis method based on volt-ampere characteristics [1] to provide additional information useful for battery SoH determination. The method is developed for solid oxide fuel cells in respect to degradation monitoring and diagnostics and ensures increased sensitivity and information capability. The additional information extraction is based on one of the main method advantages - high sensitivity of small deviations due to its operation with derivatives. In batteries, as opposed to fuel cells, there is another variable – the state of charge (SoC), which affects the determination of other parameters including the SoH. In these first results the parameter SoC is assumed to be a constant. Additionally, a procedure for initial selection of characteristic points is formulated. It ensures more detailed information regarding the battery state. The results presented are based on cycling experiments on several types of batteries.

*Acknowledgements:* This work was supported by the Bulgarian Ministry of Education and Science under the National Research Programme E+: Low Carbon Energy for the Transport and Households, grant agreement D01-214/2018 and partially under the National Roadmap for Research Infrastructure (2017-2023): Research Infrastructure Energy Storage and Hydrogen Energetics NI SEVE, grant agreement D01-160/28.08.18

### References

1. Z. Stoynov, D. Vladikova, B. Burdin, J. Laurencin, D. Montinaro, G. Raikova, G. Schiller, P. Szabo, *Differential analysis of SOFC current-voltage characteristics* **228** (2018) 1584-1590 (<https://doi.org/10.1016/j.apenergy.2018.06.138>)

## Morphology control of aluminium anodes in secondary aluminium batteries

Sandra Steiner<sup>a</sup>, David Moser<sup>b</sup>, Gerald Kothleitner<sup>b</sup>, Bernhard Gollas<sup>a</sup>

<sup>a</sup>*Institute for Chemistry and Technology of Materials, Graz University of Technology, Stremayrgasse 9/II, 8010 Graz, Austria*

<sup>b</sup>*Institute of Electron Microscopy and Nanoanalysis (FELMI), Graz University of Technology, Steyrergasse 17, 8010 Graz, Austria*  
[sandra.steiner@tugraz.at](mailto:sandra.steiner@tugraz.at)

The production of cheap and sustainable batteries with long lifetimes that can compete with Li-ion batteries has been of great interest in recent years. A promising alternative are Al-ion batteries, which promise high energy density and low prices. One of the key objectives in the production of secondary Al batteries (e.g. Al-sulfur or Al-graphite batteries) is compact Al deposition with high cycling efficiency.<sup>1</sup> However, aluminium, similar to Li, is prone to dendritic growth ultimately leading to device failure.<sup>2</sup> In our work, the deposition characteristics of the aluminium electrode were tested in two deep eutectic solvents (DES) based on aluminium trichloride and acetamide or urea.<sup>3,4</sup> The open-circuit potential after immersion in the DES was monitored to obtain information about the surface state of the pure Al in contact with the electrolyte showing initial passivation of the surface. Electrochemical impedance data revealed that the electrolyte attacks the native oxide film only at certain sites creating pits of active Al on the surface (pitting corrosion), but the remaining area remained in the passive state.<sup>5</sup> Therefore, Al deposition was subject to high local current densities at pit sites, resulting in dendritic growth.<sup>6</sup> In an attempt to remove the passive layer in-situ, current and potential controlled methods were tested. Alternating excursions to high anodic and cathodic potentials led to more uniform surface depassivation. These methods, however, are not feasible for the use in batteries, since the potential excursions would cause severe damage to the cathode materials. A promising strategy that mitigates the formation of a native oxide film and also aids in the prevention of dendrite formation, is the introduction of dopant metals to form near-surface alloys.<sup>7</sup> Therefore, different combinations of metal dopants were introduced into the Al anodes, which should lower the probability of dendrite formation and mediate compact Al deposition. The alloys were tested regarding their charge/discharge behaviour in the DES while surface morphologies were studied using SEM. The alloys showed positive effects on the surface depassivation and the growth morphology, lowering local current densities and promoting compact Al deposition.<sup>2</sup> Since battery safety is also a prime objective, the effect of the Al alloys was also studied when using polymer gel electrolytes.

### References

1. Angell, M.; Pan, C.-J.; Rong, Y.; Yuan, C.; Lin, M.-C.; Hwang, B.-J.; Dai, H., *Proc. Natl. Acad. Sci.* **114** (2017) 834–839 (<https://doi.org/10.1073/pnas.1619795114>)
2. Tu, X.; Zhang, J.; Zhang, M.; Cai, Y.; Lang, H.; Tian, G.; Wang, Y., *RSC Adv.* **7** (2017) 14790–14796 (<https://doi.org/10.1039/c6ra27217g>)
3. Abood, H. M. A.; Abbott, A. P.; Ballantyne, A. D.; Ryder, K. S., *Chem. Commun.* **47** (2011) 3523–3525 (<https://doi.org/10.1039/c0cc04989a>)
4. Liu, C.; Chen, W.; Wu, Z.; Gao, B.; Hu, X.; Shi, Z.; Wang, Z., *J. Mol. Liq.* **247** (2017) 57–63 (<https://doi.org/10.1016/j.molliq.2017.09.091>)
5. Kühnel, R. S.; Lübke, M.; Winter, M.; Passerini, S.; Balducci, A., *J. Power Sources*, **214** (2012) 178–184 (<https://doi.org/10.1016/j.jpowsour.2012.04.054>)
6. Sun, H.; Wang, W.; Yu, Z.; Yuan, Y.; Wang, S.; Jiao, S., *Chem. Commun.* **51** (2015), 11892–11895 (<https://doi.org/10.1039/C5CC00542F>)
7. Senel, E.; Nisancioglu, K., *Corros. Sci.* **88** (2014) 280–290 (<https://doi.org/10.1016/j.corsci.2014.07.040>)
- 8.

## Porous composite electrode from pyrolyzed rice husk for rechargeable zinc battery

Kaewta Jetsrisuparb, Sawitta Triamthaisong, Nontipa Supanchaiyamat<sup>1</sup>, Andrew Hunt<sup>1</sup>, Wirat Jarernboon<sup>2</sup>,  
Chaiyaput Kruehong, Pornnapa Kasemsiri, Prinya Chindapasirt<sup>3</sup>

*Department of Chemical Engineering, Faculty of Engineering, Khon Kaen University, Khon Kaen 40002, Thailand*

<sup>1</sup>*Department of Chemistry, Faculty of Science, Khon Kaen University, Khon Kaen 40002, Thailand*

<sup>2</sup>*Department of Physics, Faculty of Science, Khon Kaen University, Khon Kaen 40002, Thailand*

<sup>3</sup>*Department of Civil Engineering, Faculty of Engineering, Khon Kaen University, Khon Kaen 40002, Thailand*  
[kaewta@kku.ac.th](mailto:kaewta@kku.ac.th)

Global environmental concerns and increasing energy demands are the main drive to move from fossil fuels to renewable energy such as wind or solar. The key to sustainable energy development is by coupling low cost battery with renewable energy resources. Zinc has received considerable attention as anode material for battery applications due to its attractive cost, safety, availability and recyclability. However, zinc-based rechargeable batteries suffer from capacity fading owing to dendrite formation during charging which significantly reduces battery lifetime. Various attempts have been carried out to improve the cycle life such as implementing the flowing electrolyte battery arrangement, allowing the disruption of the zinc dendrite formation and reducing the onset of passivation during discharge. Yet, the flow-assisted battery incorporates moving parts (*e.g.* motor and pump) which may be less attractive for mobile applications. Incorporation of porous zinc electrode has shown to suppress formation of zinc dendrites by accommodating zinc oxidation products in the pores. Thus, the zinc particles are neat and active, resulting in cycling reversibility of zinc anode. Incorporation of porous additive can prevent premature death of the battery. However, the cost of additives contributes to the total cost of the battery system.

In this work, the cycle performance of zinc anode in alkaline electrolyte by addition of porous carbon from biochar is investigated. Addition of the prepared porous materials in zinc anode composite may offer the potential advantage of low cost and simple porous electrode preparation. The porous carbon was prepared by pyrolysis of rice husk as agricultural waste, and subsequently added to the electrode paste to form a porous zinc electrode. The presence of 12 wt% of porous carbon materials from rice husk reduces the capacity loss of zinc/MnO<sub>2</sub> battery, however, it is also accompanied with an increase in polarization and inadequate battery performance. A dramatic capacity loss after the 1<sup>st</sup> discharge cycle was observed. The porous carbon contributes to the change of the electrode surface after cycling. Adequate amount of porous structure may provide higher zinc utilization. The electrochemical behaviour of the porous zinc anode was characterized by cyclic voltammetry and morphological analysis will be discussed.

### References

1. M. N. Masri, A. A. Mohamad, *Journal of The Electrochemical Society* **160** (2013) A715-A721  
(<http://dx.doi.org/10.1149/2.007306jes>)
2. H. Li, C. Xu, C. Han, Y. Chen, C. Wei, B. Li, F. Kang, *Journal of The Electrochemical Society* **162** (2015) A1439-A1444  
(<https://doi.org/10.1149/2.0141508jes>)

## Zeolite based gas-diffusion electrodes for secondary metal air batteries

Miglena Slavova, Elena Mihaylova, Emilia Mladenova, Blagoy Burdin, Borislav Abrashev, Daria Vladikova

*Institute of Electrochemistry and Energy Systems "Academician Evgeni Budevski"*

*Acad. Georgi Bonchev 10 Str., 1113 Sofia, Bulgaria*

[m Slavova@iees.bas.bg](mailto:m Slavova@iees.bas.bg)

In recent years, secondary metal air batteries have received considerable attention as promising technology for energy storage in combination with renewable energy sources. The aim of this work is to study a gas-diffusion layer in which carbon-based material is replaced with zeolite. The oxidation of carbon in conventional gas-diffusion electrodes reduces the life of the secondary metal-air batteries. Replacement of the carbon-based material with zeolite is a possible solution for overcoming this problem.

Zeolite is a natural or synthetic porous material. The presence of pores in it provides the necessary gas permeability. The electrode gas-diffusion layer should also have good hydrophobicity to prevent the electrolyte from leaking out of the battery. Mixing the zeolite with an appropriate amount of polytetrafluoroethylene in a specially developed procedure provides the required hydrophobicity of the electrodes.

The experiments are performed in specially designed test cell. Its construction ensures measurements of the bifunctional gas-diffusion electrode in half-cell configuration applying reference hydrogen electrode. The cell is subjected to cycling at charge/discharge current  $\pm 10 \text{ mA/cm}^2$  respectively.

The obtained first results show that the zeolite is a suitable material to replace carbon in secondary metal air batteries for renewable solar energy as it provides the required number of charging / dilution cycles with a suitable C rate.

*Acknowledgements:* This work was supported by the Bulgarian Ministry of Education and Science under the National Research Programme E+: Low Carbon Energy for the Transport and Households, grant agreement D01-214/2018 and the National Roadmap for Research Infrastructure (2017-2023): Research Infrastructure Energy Storage and Hydrogen Energetics NI SEVE, grant agreement D01-160/28.08.18

## The influence of conductivity and pH on the performance of electric double layer capacitors working in neutral electrolytes

Ilona Acznik, Katarzyna Lota

*Institute of Non-Ferrous Metals Division in Poznan, Central Laboratory of Batteries and Cells*

*Forteczna 12, 61-362 Poznań, Poland*

[ilona.acznik@claio.poznan.pl](mailto:ilona.acznik@claio.poznan.pl)

Development of electrochemical capacitors focuses today on the improvement of their energy density (or specific energy) and cyclability. The energy density might be improved by capacitance enhancement and operating voltage increase. Capacitance is closely related to the electrode material, while the operating voltage depends on the type of electrolyte. Of course, they cannot be considered separately, since the final performance is always a combination of various factors.

The electrolyte-related issues create an interesting pathway for investigations aiming at maximum voltage increase and energy density enhancement. Undoubtedly, organic media (based on acetonitrile or propylene carbonate) and ionic liquids are the optimal electrolytic solutions in terms of electrochemical stability. However, their impact on the environment and user safety is quite often questioned. Water-based electrolytes seem to be an interesting alternative, but the major objection against their commercialization concerns their low electrochemical stability governed by water decomposition voltage.

Since the significant disadvantage of water-based solutions is attributed to the solvent decomposition, in this work we focused on determining the correlation between electrolyte concentration and electrochemical performance, while increasing the voltage window. It was assumed that as the water content in the electrolyte decrease, its stability will improve. Nevertheless, an increase in salt concentration may not only lead to conductivity increase/decrease, but it can also change electrolyte pH, which is not always the desired effect. Moreover, as can be seen in Fig. 1, the type of cation (or anion) also affects electrolytes parameters. Hence, the efficiency of the electrochemical system can change significantly.

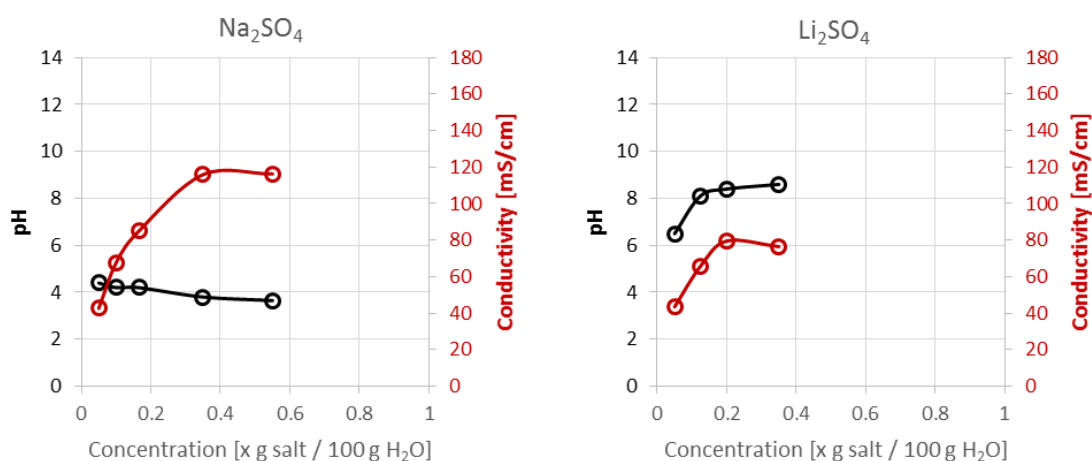

Fig. 1 The dependence of pH and conductivity on the salt concentration in the electrolyte

The authors acknowledge the financial support from the Polish Ministry of Science and Education – Grant No 3787/E-138/S/2019.

## The electrochemical properties of nitrogen-doped carbon materials

Katarzyna Lota<sup>1</sup>, Ilona Acznik<sup>1</sup>, Agnieszka Sierczynska<sup>1</sup>, Lukasz Kolanowski<sup>1</sup>, Grzegorz Lota<sup>2</sup>

<sup>1</sup>*Institute of Non-Ferrous Metals Division in Poznan, Central Laboratory of Batteries and Cells, Forteczna 12, 61-362 Poznan, Poland*

<sup>2</sup>*Poznan University of Technology, Institute of Chemistry and Technical Electrochemistry, Berdychowo 4, 60-965 Poznan, Poland*

[katarzyna.lota@claio.poznan.pl](mailto:katarzyna.lota@claio.poznan.pl)

Carbon materials are widely used in many applications. Attractive properties of active carbon materials result from the well-developed surface area and the type and amount of different heteroatoms (such as: oxygen, sulphur, nitrogen, boron, phosphorus, chlorine) on their surface. One of possible applications of carbons is the electrochemical field, as electrode materials for electrochemical capacitors. Functional groups or heteroatoms such as nitrogen can increase the charge-exchange characteristics of carbon, leading to enhancement of electrochemical capacitance.

One of the methods, which was applied to increase nitrogen content was the ball milling. The nitrogen compound used in the process was in liquid phase, while carbon materials were added as a solid compound. For comparison process of carbonizing precursors enriched in nitrogen *i.e.* chitosan or polyaniline was applied. Additionally, the method of KOH activation to obtain the porous carbons was used. The so-prepared carbon materials/nanomaterials before and after the nitrogen doping process were characterized by scanning electron microscopy (SEM), the thermogravimetric analysis (TGA), and specific surface area measurements with pore distribution. The carbon and nitrogen content was estimated using the elemental analysis. The synthesized carbon nitrogen-enriched materials were tested in acidic medium. The specific capacitances of prepared materials were obtained using three techniques: cyclic voltammetry, galvanostatic charge/discharge and electrochemical impedance spectroscopy. The porosity and surface area as well as the nitrogen content strongly depend on the temperature of activation.

The activated carbon from chitosan shows good rate capability and excellent cycling stability - almost 99 % capacitance retention over 5000 cycles.

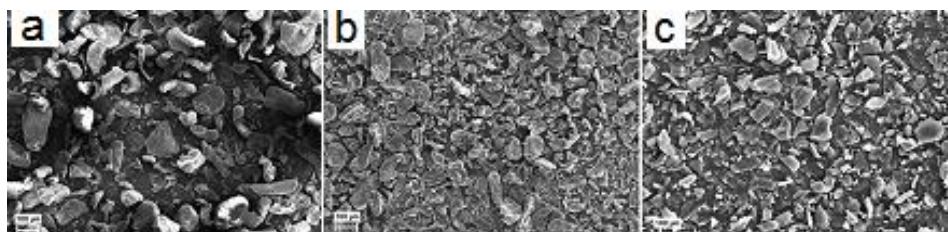

Fig. 1. SEM images of (a) chitosan, (b) carbonized chitosan, (c) carbonized and then activated chitosan

*Acknowledgements:* The authors acknowledge the financial support from the Ministry of Science and Education (Poland) – Grant no 3787/E-138/S/2019.

## Supercapacitors based on reduced graphene oxide hydrogels

Denis Sačer<sup>1</sup>, Suzana Sopčić<sup>1</sup>, Davor Antonić<sup>1</sup>, Davor Čapeta<sup>2</sup>, Marijana Kraljić Roković<sup>2</sup>

<sup>1</sup>Faculty of Chemical Engineering and Technology, University of Zagreb, Marulićev trg 19, 10000 Zagreb, Croatia

<sup>2</sup>Institute of Physics, Bijenička 46, 10000 Zagreb, Croatia

Graphene is a monolayer of carbon atoms which due to delocalized  $\pi$  electrons possesses a good electrical conductivity. Good electrical conductivity and large specific surface area of graphene enable its application in electrochemical energy storage devices. Physical and chemical properties of graphene, as well as, its sheet size depend on the synthesis method. In this work, graphene was chemically synthesized using graphite as precursors. In the first step of synthesis graphene oxide (GO) was obtained and in the next step it was reduced. The reduction of GO is a crucial step in which it is necessary to remove a variety of oxygen functional groups bonded to the graphene sheet. For the reduction process it is desirable to achieve a high degree of reduction and good electron conductivity and to prevent the graphene agglomeration. By using hydrothermal procedure it is possible to archive all these demands [1,2].

In this work reduced graphene oxide (rGO) was prepared by hydrothermal procedure supported by olive leaf extract (OLE) at different pH values. Structural and morphological characteristics of the obtained materials were determined by Raman spectroscopy, X-ray diffraction analysis (XRD), Fourier-transformed infrared spectroscopy (FTIR), thermogravimetric analysis (TGA) and scanning electron microscopy (SEM). By using cyclic voltammetry and electrochemical impedance spectroscopy (EIS) methods it was shown that all prepared materials exhibited good capacitive properties in  $0.5 \text{ mol dm}^{-3} \text{ Na}_2\text{SO}_4$  supporting electrolyte. The prepared materials were used to assemble supercapacitors (Fig.1) that were tested by cyclic voltammetry and EIS methods. The stability of the supercapacitors was determined by charging/discharging at constant current during 1000 cycles.

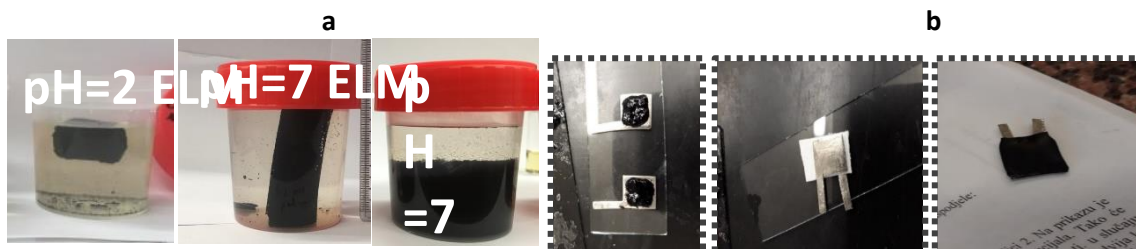

Fig.1. a) Hydrogels obtained at different pH values in the presence and without the presence of OLE and b) assembly of supercapacitor containing graphene hydrogel.

### References

1. K. Hu, X. Xie, T. Szkopek, M. Cerruti, *Chem. Mater.* 28 (2016) 1756-1768.
2. S. P. Sasikala, P. Poulin, C. Aymonier, *Adv. Mater* (2017) 1605473.

## Highly efficient carbon-free membrane electrode assemblies for electrolysis cells with anion exchange membrane (AEMEC)

Galin Borisov, Denis Paskalev, Katerina Maksimova-Dimitrova, Elitsa Petkucheva, Evelina Slavcheva

*Institute of Electrochemistry and Energy Systems "Acad. Evgeni Budevski",*

*Bulgarian Academy of Sciences, 1113 Sofia, Bulgaria*

[gbl.rusev@iees.bas.bg](mailto:gbl.rusev@iees.bas.bg)

The AEM water electrolysis based on alkali-doped polymer electrolyte membrane is an efficient method to produce hydrogen with higher purity, which offers several advantages as high current density, low ohmic resistance, possibility to operate at higher working pressure, as well as usage of platinum free electrocatalysts. The technology still has some problems such as non-sufficient stability of the polymer electrolyte at elevated temperature, low conductivity of the commercially available membranes, and intensive corrosion on the gas diffusion electrodes and bipolar plates of the cell. This work presents a newly developed laboratory prototype of hydrogen generator, operating with anion exchange membrane (AEM) and temperature limit up to 95°C. The device combines the advantages of the traditional alkaline and the contemporary polymer electrolyte membrane (PEM) water electrolysis. The electrodes for both partial reactions are carbon free 3 layer-designed structures with active surface of 5 cm<sup>2</sup>. The active materials for both partial reactions are Ni and Co (40% wt.) dispersed over the nonstoichiometric titanium oxide with excellent electrical conductivity and stable electrochemical behavior. A commercial AB-PBI polymer membrane is used as OH-conductive electrolyte, doped directly into the cell. It is found that the optimum doping time of the membrane varies from 30 min to 45 min at cell voltage of 30 V and temperature of 25°C. After polymer membrane activation the hydrogen generation process at increased temperature of 95°C runs with current density of about 250 mA.cm<sup>-2</sup>. After 168 h in operando mode (start – stop procedure), the cell demonstrates stable electrochemical behaviour without any signs of degradation. The enhanced efficiency of the electrolysis is explained with the observed homogeneous distribution of the nano-sized catalyst crystallites on the non-carbon carrier, combined with high anion conductivity of the used polymer electrolyte membrane.

*Acknowledgments:* This work was supported by the Bulgarian Ministry of Education and Science under the National Research Programme E+: Low Carbon Energy for the Transport and Households, grant agreement D01-214/2018 and partially under the National Roadmap for Research Infrastructure (2017-2023): Research Infrastructure Energy Storage and Hydrogen Energetics NI SEVE, grant agreement D01-160/28.08.18

# **Materials and Electrochemical Processing & Electrochemical Engineering**

## The advent of 2D layered materials for electrochemical energy applications

Rui Gusmão, Zdeněk Sofer, Martin Pumera

Center for Advanced Functional Nanorobots, Department of Inorganic Chemistry, University of Chemistry and Technology (VŠCHT), Praha, Czech Republic

[Rui.Jorge.Coelho.Gusmao@vscht.cz](mailto:Rui.Jorge.Coelho.Gusmao@vscht.cz)

There has been immense interest in two dimensional (2D) and quasi-2D materials since the past decade, initiated by the re-introduction of graphene exciting and highly unusual physical, chemical and materials properties. Many of these properties originate from atomic thickness of the graphene sheet as well as from its anisotropy. There is similar growing attention in layered transition metal dichalcogenides (TMD), which can be exfoliated to single sheets  $\text{MX}_2$  — where M is transition metal, such as Mo, W, V, or Pt and X is chalcogen S, Se or Te.<sup>1</sup> These single sheet is not truly a one atom thick, with metal atom sandwiched between chalcogen atoms in X-M-X configuration. Recently, another elemental layered material re-emerged, the orthorhombic black phosphorus (BP), soon followed by the other pnictogenenes (single layer of rhombohedral As, Sb and Bi).<sup>2,3</sup> Many of these materials are constantly sought and being tested in energy related applications.<sup>4</sup>

The communication will demonstrate that aqueous shear force exfoliation can be used to obtain 2D exfoliated nanosheets with semiconductor and topological insulators features.<sup>5-7</sup> Morphological and chemical characterization of the exfoliated materials shows a decrease in thickness, sheet to nanosheet scale and partial oxidation due to the higher surface area. Nanosheets degradation can be minored with functionalization strategies.<sup>8</sup> Electrochemical performances are tested in terms of inherent electrochemistry and heterogeneous electron transfer. Potential energy-related applications are evaluated in the hydrogen evolution reaction (HER), oxygen evolution reaction (OER), oxygen reduction reaction (ORR) and galvanostatic capacitance, testing the material with for the best electrochemical performance. These findings can have a profound impact on the preparation and energy applications of 2D layered materials.

### References

1. Chia, X. & Pumera, M. *Nat. Catal.* **1**, (2018) 909–921.
2. Hirsch, A. & Hauke, F. *Angew. Chemie - Int. Ed.* **57**, (2018) 4338–4354.
3. Zhang, S. *et al. Chem. Soc. Rev.* **47**, (2018) 982–1021.
4. Khan, A. H. *et al. Bull. Chem. Soc. Jpn.* **90**, (2017) 627–648.
5. Gusmão, R., Sofer, Z. & Pumera, M. *Adv. Funct. Mater.* **29**, (2018) 1805975.
6. Gusmão, R., Sofer, Z., Luxa, J. & Pumera, M. *J. Mater. Chem. A* **6**, (2018) 16590–16599.
7. Gusmão, R., Sofer, Z., Bouša, D. & Pumera, M. *Angew. Chemie - Int. Ed.* **56**, (2017) 14417–14422.
8. Gusmão, R., Sofer, Z. & Pumera, M. *ACS Nano* **12**, (2018) 5666–5673.

## Electrochemical approaches in synthesis of high surface area materials

Lidija D. Rafailović<sup>1</sup>, Christoph Gammer<sup>2</sup>, Tomislav Trišović<sup>3</sup>, Bernhard Lutzer<sup>1</sup>, Christian Rentenberger<sup>4</sup>, Aleksandar Z. Jovanović<sup>5</sup>, Igor A. Pašti<sup>5</sup>, H. Peter Karnthaler<sup>4</sup>

<sup>1</sup>CEST, Centre of Electrochemical Surface Technology, Wr. Neustadt, Austria

<sup>2</sup>Erich Schmid Institute of Materials Science, Leoben, Austria

<sup>3</sup>Institute of Technical Sciences of the Serbian Academy of Sciences and Arts, Belgrade, Serbia

<sup>4</sup>University of Vienna, Faculty of Physics, Physics of Nanostructured Materials, Vienna, Austria

<sup>5</sup>University of Belgrade, Faculty of Physical Chemistry, Belgrade, Serbia

[lidija.rafailovic@cest.at](mailto:lidija.rafailovic@cest.at)

It is the aim of our work to carry out fundamental studies on designing and synthesizing high surface area functionalized foam and ordered structures for their potential sensing and energy related applications. We combine electrochemical synthesis with structural studies on different length scales including transmission electron microscopy. Templates are directly grown by electrodeposition, either by hydrogen bubble formation or by utilizing of ordered structures formed by anodic electrochemical oxidation. [1-3] We employed an elegant approach to obtain open, foam deposits of Ni and Ni alloys, by using electrodeposition at high current densities, to promote hydrogen evolution and bubble templating (cf. Fig.1). [1] In the next step, the high surface area of such materials was functionalized by Pd utilizing galvanic displacement reaction. Electrochemical testing of the obtained open foam deposits shows promising catalytical activity for hydrogen evolution in alkaline environments, as well as methanol and ethanol oxidation. In the case of fabrication of nanodendritic Ag simultaneously grown with porous anodic aluminium oxide we accomplished well anchored dendritic Ag nanostructures [2] of long-term stability [3].

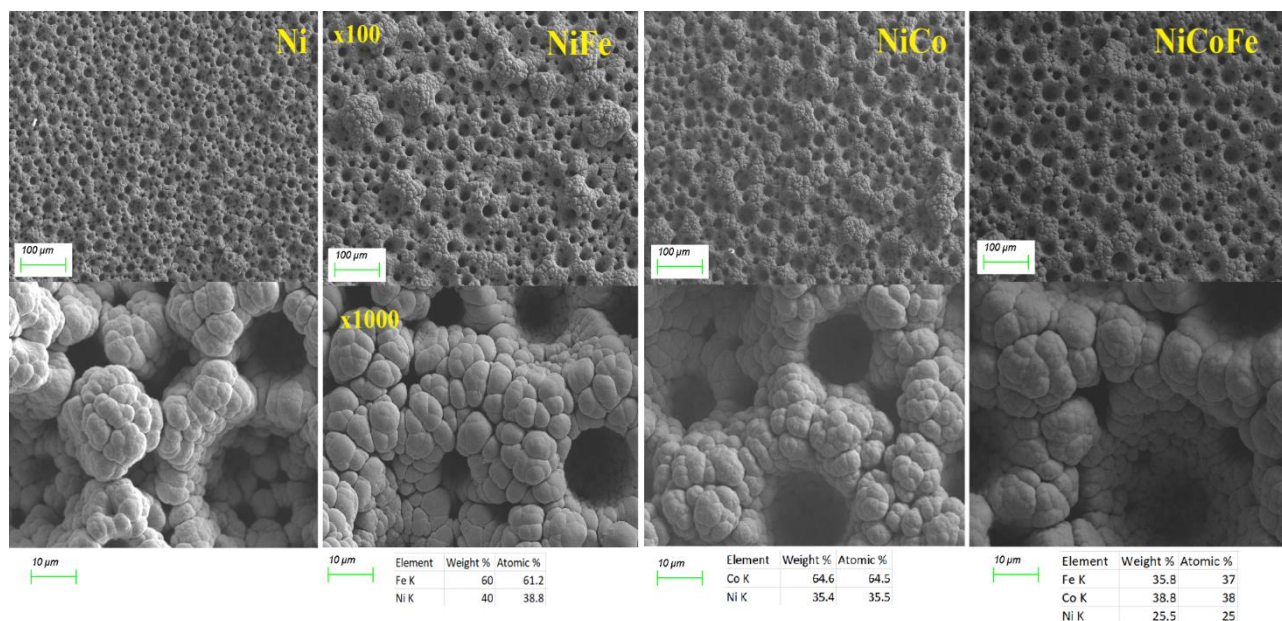

Figure 1. Sem images of high surface area Ni and Ni alloys obtained by dynamic hydrogen template bubble deposition.

### References

1. L. D. Rafailović, C. Gammer, C. Rentenberger, T. Trišović, C. Kleber, H. P. Karnthaler, *Nano Energy*, **2** (2012) 523 <https://doi.org/10.1016/j.nanoen.2012.12.004>
2. L.D. Rafailovic, C. Gammer, C. Rentenberger, T. Trisovic, C. Kleber, H.P. Karnthaler, *Adv. Mater.* **27** (2015) 6438 <https://doi.org/10.1002/adma.201502451>
3. L.D. Rafailovic, C. Gammer, J. Srajer, T. Trisovic, J. Rahel, H.P. Karnthaler; *RSC Adv.*, **6** (2016) 33348, <https://doi.org/10.1039/c5ra26632g>

## Cu<sub>2</sub>ZnSnS<sub>4</sub> prepared sulfurizing a stack of electrodeposited metallic layers

Gonzalo Perelstein<sup>1</sup>, Antonio da Cunha<sup>2</sup>, [Marcela Vazquez](mailto:mvazquez@fi.mdp.edu.ar)<sup>1</sup>, Matías Valdés<sup>1</sup>

<sup>1</sup>INTEMA, UNMDP-CONICET, Colón 10850, (7600) Mar del Plata, Argentina

<sup>2</sup>Departamento de Física, Universidade de Aveiro, (3810-193) Aveiro, Portugal  
[mvazquez@fi.mdp.edu.ar](mailto:mvazquez@fi.mdp.edu.ar)

Cu<sub>2</sub>ZnSnS<sub>4</sub> (CZTS) is an extensively studied kesterite that can be used as absorber layer in inorganic solar cells. A direct bandgap energy value ( $E_{\text{GAP}}$ ) close to 1.5 eV and a high absorption coefficient make it a suitable material for this purpose [1]. Furthermore, compared to competing family compounds such as chalcopyrites (CuInGaSe<sub>2</sub>), it has the advantage of including “green”, inexpensive and abundant elements. CZTS films are thus excellent candidates for low-cost, highly efficient and environmentally friendly thin-film solar cells [2]. There are numerous electrochemical routes to deposit CZTS. In a previous work [3] we explored the so-called “one-pot” electrodeposition but we found it difficult to stabilize the sulfur source in the precursor mixture. Later [4], we explored with the co-electrodeposition of a Cu-Zn-Sn precursor (CZT) from a ternary precursor bath, followed by a sulfurization stage that transforms the precursor into CZTS. This work describes the consecutive electrodeposition of metallic thin films (Cu, Sn and Zn) on conductive glass, which transforms in CZTS after the sulfurization treatment. The thickness of each metallic layer was calculated by coulometry and ranged between 200 and 320 nm. The Cu-Sn-Zn stack was first annealed at 350 °C during 30 min and later underwent reactive sulfurization at either 500 or 585 °C for 10 min. The vaporized sulfur reached the samples assisted by N<sub>2</sub> flux. CZTS films were characterized by Raman spectroscopy, scanning electronic microscopy (SEM), and UV-Vis spectroscopy. SEM results showed good coverage and homogenous morphology. Raman spectroscopy confirmed the formation of crystalline CZTS after sulfurization, with no secondary phases detected in the film. The bands are sharp and clear particularly for those samples annealed at 585 °C. Direct energy gap values close to 1.5 eV were estimated for CZTS films by UV-Vis spectroscopy. CZTS films are good-quality absorbers suitable to be used in kesterite thin films solar cells. The same procedure has been tested using Mo-coated glass as substrates, so that different architectures (substrate and superstrate solar cells) can be chosen using this deposition methodology.

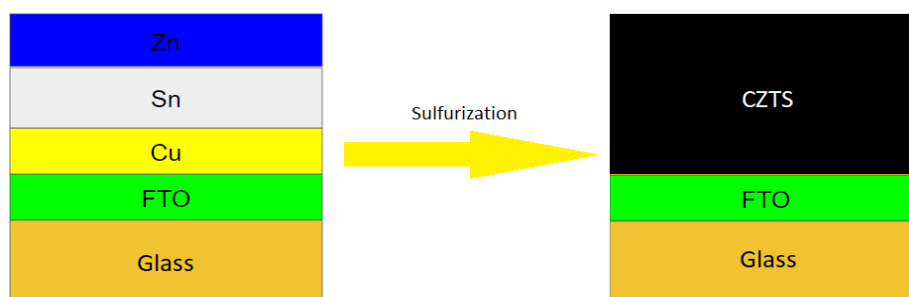

Fig 1: Scheme of the metal precursors before the sulfurized and the CZTS after the sulfurized.

### References

1. S. Siebentritt and S. Schorr, Progress in Photovoltaics: Research and Applications, **20** (2012) 512
2. T. K.Todorov, J. Tang, S. Bag, O. Gunawan, T. Gokmen, Y. Zhu, D. B. Mitzi *Advanced Energy Materials*, **3** (2013) 34
3. G. Perelstein, M. Valdes, M. Vazquez. ECS Transactions, **80** (2017) 703
4. G. Perelstein, M. Valdes, M. Vazquez. *Materialia* **5** (2019) 100187

## One-pot synthesis of CNT/Ni electrocatalysts using electrophoretic deposition

Jesper T. N. Knijnenburg<sup>1</sup>, Napapon Massa-Angkul<sup>2</sup>, Kaewta Jetsrisuparb<sup>2</sup>

<sup>1</sup>International College, Khon Kaen University, Khon Kaen, 40002, Thailand

<sup>2</sup>Faculty of Engineering, Khon Kaen University, Khon Kaen, 40002, Thailand

[jespth@kku.ac.th](mailto:jespth@kku.ac.th)

The excessive use of fossil fuels negatively impacts the environment through production of CO<sub>2</sub> and other harmful substances. There is thus a strong need for reliable, cost-effective, and renewable clean energy sources. Hydrogen as an energy carrier can be produced from clean energy sources such as water through electrolysis. Water electrolysis is considered a promising approach to produce carbon-free energy when coupled with electricity produced from renewable sources such as wind or solar. In addition, this process can deliver high purity hydrogen and oxygen (1). However, a major challenge remains the high overpotential at the oxygen electrode and the use of expensive noble metals (*e.g.*, Ru or Pt) as electrocatalysts to facilitate the oxygen evolution reaction (OER). As an alternative, carbon nanotubes (CNTs) were found to reduce OER overpotential because of the presence of defects on the nanotubes which facilitate the dissociation of hydroxide ions into oxygen (2). This work presents the one-pot synthesis of CNT-loaded Ni foam electrocatalysts using electrophoretic deposition (EPD). EPD is a simple and versatile technique for deposition of colloidal materials from suspension onto various shapes of conductive substrate (3). The CNTs were activated through acid modification, which was directly followed by EPD onto Ni foam substrate. This one-pot synthesis method avoids the tedious multi-step separation and drying of acid-modified CNT. Surface modification resulted in a stable aqueous suspension under neutral conditions as confirmed by UV-vis spectroscopy. The amount of CNTs onto Ni foam substrate can be controlled through CNT concentration, deposition time and the applied voltages. The modified CNTs have been characterized using infrared and Raman spectroscopy, X-ray diffraction, and electron microscopy techniques. Potential use of the prepared electrode in alkaline electrolysis in hydrogen production will be presented and discussed.

### References

1. B. Kropolski, J. Levene, K. Harrison, P.K. Sen, F. Novachek, Electrolysis: Information and Opportunities for Electric Power Utilities, *Technical Report NREL/TP-58140605* (2006) (<https://www.nrel.gov/docs/fy06osti/40605.pdf>)
2. P.K. Dubey, A.S.K. Sinha, S. Talapatra, N. Koratkar, P.M. Ajayan, O.N. Srivastava, *International Journal of Hydrogen Energy* **35** (2010) 2945-3950 (<https://doi.org/10.1016/j.ijhydene.2010.01.139>)
3. A.R. Boccaccini, J. Cho, J.A. Roether, B.J.C. Thomas, E.J. Minay, M.S.P. Shaffer, *Carbon* **44** (2006) 3149-3160 (<https://doi.org/10.1016/j.carbon.2006.06.021>)

## Electrocatalysts incorporating higher fullerenes and DWCNTs

Georg Pchelarov, Dzhamal Uzun, Konstantin Petrov

Institute of Electrochemistry and Energy Systems, Bulgarian Academy of Sciences,

G. Bonchev St., Building 10, 1113 Sofia, Bulgaria

[g.pchelarov@iees.bas.bg](mailto:g.pchelarov@iees.bas.bg)

This work considers the possibility of using new electro-catalytic materials. The possibility of using fullerenes as promising catalysts has been considered in the past. In the present study we utilize higher fullerenes as fabricated by applying the carbon arc method in a quartz reactor designed for both production and subsequent sublimation. Higher fullerenes are small-bandgap fullerenes currently commercially available from Sigma Aldrich. These include the fairly stable species  $C_{74}$ ,  $C_{78}$ ,  $C_{80}$ ,  $C_{82}$ ,  $C_{84}$ ,  $C_{86}$ ,  $C_{88}$ ,  $C_{90}$ ,  $C_{92}$ ,  $C_{94}$ ,  $C_{96}$ ,  $C_{98}$ ,  $C_{100}$ . Larger species become unstable as they grow in size. Characteristic of higher fullerenes is that the bonding sites between pentagon atom groups are usually found to be the most reactive. In this study we have applied a new method to fabricate the electro-catalyst for the fuel cell electrodes. We used higher fullerenes to maximize the electro-active surface area of the catalyst. Higher fullerenes were dispersed in distilled water in a sonic bath. Next, manganese acetate and polypyrrole were slowly added to the aqueous suspension. These ternary components were then baked at 180 °C for 12h in a Teflon autoclave. Thus, Mn particles were deposited on the higher fullerene lattice structures with polypyrrole binding. X-ray diffraction studies were carried out on a wide range of samples with different type and quantity of catalyst. The catalysts were then applied in the process of oxidation of sulfites to sulfates in solution. The solution was sodium sulfite with the addition of NaCl. The electrodes were characterized by SEM, cyclic voltammetry, steady state polarization curves and Tafel slope analysis.

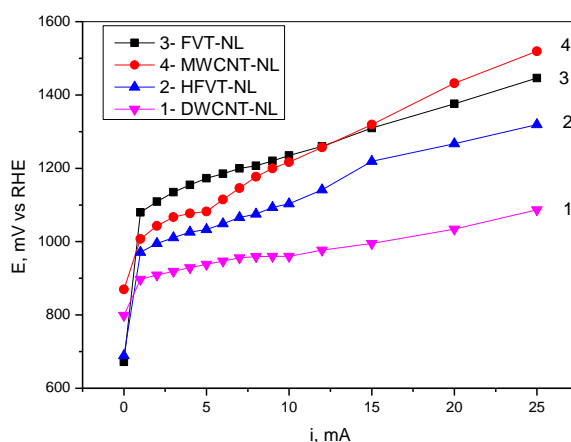

Shown in the figure are the dependencies of the electrode potential vs. the current density for the oxidation of sulphites on electrodes fabricated incorporating different catalysts: 1 - (DWCNTVT) – double wall carbon nanotubes; 2 - (HFVT) - higher fullerenes; 3 - (FVT) - fullerenes  $C_{60}/C_{70}$ ; 4 - (MWCNTVT) - multiwall carbon nanotubes. The electrolyte is: 1 M  $Na_2 SO_3$  + 18 mg/l NaCl;  $T = 20$  °C.

## Tracking and modeling of PtCu nanoalloy dealloying at the atomic-scale: spot the difference “game” at the atomic level

Nejc Hodnik<sup>1</sup>, Matija Gatalo<sup>2</sup>, Francisco Ruiz-Zepeda<sup>2</sup>, Andraž Pavlišič<sup>1</sup>, Primož Jovanovič<sup>1</sup>, Marjan Bele<sup>2</sup>, Goran Dražič<sup>2</sup>, Miran Gaberšček<sup>2</sup>

<sup>1</sup> Department of Catalysis and Chemical Reaction Engineering, National Institute of Chemistry, Hajdrihova 19, 1000 Ljubljana, Slovenia

<sup>2</sup> Department of Materials Chemistry, National Institute of Chemistry, Hajdrihova 19, 1000 Ljubljana, Slovenia

[nejc.hodnik@ki.si](mailto:nejc.hodnik@ki.si)

Nanoparticles' catalytic performance is determined by the atomic structure, composition and morphology of their surface and near-surface area: also referred to as the structure-activity relationship. The materials nanoscale architecture is tailored by many parameters of the nanoparticle synthesis, post-synthesis annealing, activation (dealloying) and exposure to the reaction conditions. Therefore predicting, understanding and finally manipulating with the nanocrystals structuring processes at the atomic-scale is far from straightforward. Much progress has been achieved with respect to the synthesis procedure of the so-called as-synthesized nanoparticles. However, when particles get exposed to the real conditions and the processes of activation, such as dealloying, which create the final active centers of Pt-alloy electrocatalysts[1], much is still to be learned on the atomic-scale. As-synthesized material and activated material inside the reactor can differ significantly. This is particularly evident in the case of Pt-alloys where selective leaching of the less noble metal results in Pt surface enrichment or even porosity.[1,2] Advancements and accessibility of the electron microscopy together with groundbreaking identical location approach [1] have made it possible to track the evolution of the same nanocrystals during different treatments. Fig. 1 exemplifies the development of a PtCu-based polyhedron shaped nanoparticle containing six {100}, 12 {110} and eight {111} facets at atomic-scale resolution before and after dealloying. It is shown that anisotropic facet etching is resulting in the disappearance of the most stable {111} plane at the expense of the growth of a less stable {110} plane (Fig. 1). Observed atomic-scale dealloying mechanism is supported by Monte-Carlo simulations [2] and online dissolution measurements. Our novel advanced multidisciplinary approach paves the way to the atomic-scale understanding of the dynamic structural and morphological evolution of nanostructures and thus the establishment of the new concept of structure-stability relationship.

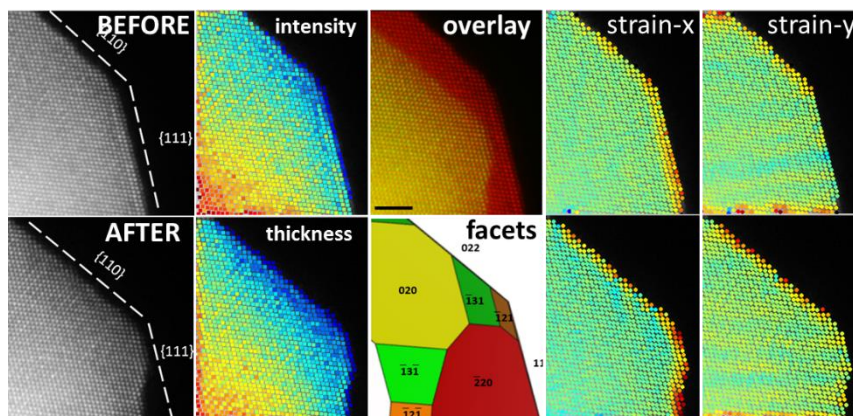

Figure 1: STEM ADF images of PtCu/C before and after dealloying (scale 2 nm). Next are intensity (thickness) profiles, overlaid STEM ADF images and below model crystal morphology and straining.

### References:

1. Nejc Hodnik, Milena Zorko, Marjan Bele, Stanko Hočevar, Miran Gaberšček, *J. Phys. Chem. C* 2012, 116 (40) 21326–21333.
2. Francisco Ruiz-Zepeda, Matija Gatalo, Primož Jovanovič, Andraž Pavlišič, Marjan Bele Nejc Hodnik Prof. Miran Gaberšček, *ChemCatChem* 2017, 20 (9) 3904-3911.

## CO-assisted *ex-situ* chemical activation of gram-scale high-performance Pt-Cu/C ORR electrocatalyst

M. Gatalo<sup>1</sup>, L. Moriau<sup>2</sup>, F. Ruiz-Zepeda<sup>1</sup>, P. Jovanovič<sup>2</sup>, U. Petek<sup>1</sup>, N. Hodnik<sup>2</sup>, M. Bele<sup>1</sup>, M. Gaberšček<sup>1</sup>

<sup>1</sup>Department of Materials Chemistry, National Institute of Chemistry, Hajdrihova 19, 1000 Ljubljana, Slovenia

<sup>2</sup>Department of Catalysis and Chemical Reaction Engineering, National Institute of Chemistry, Hajdrihova 19, 1000 Ljubljana, Slovenia

[matija.gatalo@ki.si](mailto:matija.gatalo@ki.si)

In the future, low-temperature proton exchange membrane fuel cells (PEMFC), together with batteries, are expected to compete and eventually replace conventional combustion engines in the automotive industry. Currently, the most promising strategy towards cost-effective and highly-active oxygen reduction reaction (ORR) electrocatalysts seems to be alloying of Pt with less expensive and less noble 3d transition metals (Cu, Co and Ni,...). A crucial issue to be resolved in the near future is, however, to bridge the gap between the remarkable activities measured on the laboratory scale with thin film rotating disk electrode (TF-RDE) and the industrial membrane electrode assembly (MEA). In the case of Pt-Cu alloy, one of the major reasons for this difficulty is inadequate removal of unstable Cu or in other words, improper 'activation'. Inadequately removed Cu can act as an impurity by poisoning the Pt surface via the well-known underpotential deposition (UPD) interaction, resulting in the inhibition of ORR performance. Due to highly favorable experimental conditions, *in-situ* electrochemical activation (*in-situ* EA) in TF-RDE setup masks many of the issues one experiences when trying to do the same *ex-situ*. Thus, matching the ORR performance obtained after *in-situ* EA with *ex-situ* chemical activation (*ex-situ* CA) in the case of Pt-Cu system has not been properly addressed so far. Based on a deeper understanding of *in-situ* EA of our in-house designed Pt-Cu/C electrocatalyst we here demonstrate development of carbon monoxide (CO) assisted *ex-situ* CA method (Figure 1) [1]. By using this gram scale *ex-situ* CA method, we for the first time show that a Pt-Cu system can achieve very high ORR performances in TF-RDE setup without any need for the use of *in-situ* EA.

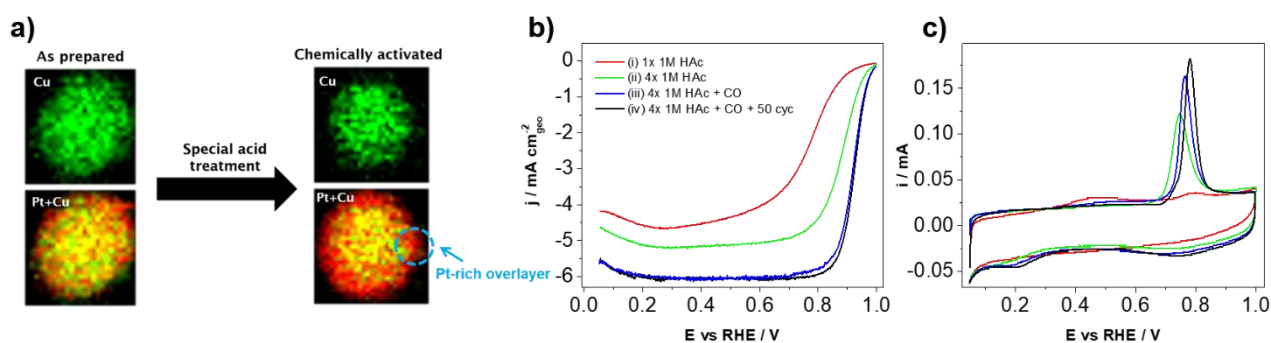

Figure 1: (a) Chemical mapping using a transmission electron microscope of a representative as-prepared Pt-Cu nanoparticle and another nanoparticle after *ex-situ* CA. Comparison of (b) ORR polarisation curves and (c) CO stripping for analogues that were activated via *ex-situ* CA protocols (i) – (iii) as well as (iv) after additional potentiodynamic cycles (0.05 – 1.2  $V_{RHE}$ , 300  $mV s^{-1}$ ) of *in-situ* EA.

### References

1. Gatalo, M., Hodnik, N., Bele, M., Jovanovič, P., Gaberšček, M., and Grom, M. (2018) Method of Treating a Platinum-alloy Catalyst, and Device for carrying out the Method of Treating a Platinum-alloy Catalyst. EP18196870.2, issued 2018.

### Novel catalysts for water splitting

Rashko Rashkov<sup>1</sup>, Vasil Bachvarov<sup>1</sup>, Marina Arnaudova<sup>1</sup>, Galin Borisov<sup>2</sup>

<sup>1</sup>*Institute of Physical Chemistry, Bulgarian Academy of Sciences, 11 Acad. G. Bonchev Str.,  
1113 Sofia, Bulgaria*

<sup>2</sup>*Institute of Electrochemistry and Energy Systems, Bulgarian Academy of Sciences,  
10 Acad. G. Bonchev Str., 1113 Sofia, Bulgaria*  
[rasho@ipc.bas.bg](mailto:rasho@ipc.bas.bg)

A new generation catalytic materials for water splitting, containing transition elements of iron group (without precious metals), were produced to generate hydrogen as a clean fuel. Alloys were deposited by galvanostatic technique from sophisticated electrolytes on various substrates. In order to improve the kinetic of electron transfer and hence the overall electrocatalytical behavior of the electrode material, several multi electrochemical deposited alloys between Ni, Co, Fe, as *hyper-d* elements with typical *hypo-d* elements such as Mo and W were obtained. Additionally, alloys/TiO<sub>x</sub> composite layers were produced. Electrochemical measurements in real membrane electrode assembly were used to study the electrocatalytic activity of the electrodes at room temperature in an alkaline media. The results show that the obtained new catalytic alloys are promising electrode materials for electrochemical water splitting.

*Acknowledgements:* This work was supported by the Bulgarian Ministry of Education and Science under the National Research Programme E+: Low Carbon Energy for the Transport and Households, grant agreement D01-214/2018.

## Comparative study of nanostructured electrocatalytic materials on 3D nickel foam for efficient water splitting

Elitsa Petkucheva, Galin Borisov, Elefteria Lefterova, Evelina Slavcheva

*Institute of Electrochemistry and Energy Systems, Acad. Evgeni Budevski''-IEES,  
Bulgarian Academy of Sciences, BAS*

[e.petkucheva@iees.bas.bg](mailto:e.petkucheva@iees.bas.bg), [elitsapetkucheva@gmail.com](mailto:elitsapetkucheva@gmail.com)

An economically viable fashion is the searching of highly efficient, stable and low-cost electrocatalysts made from earth-abundant elements for water splitting via electrolysis. In general, efficient electrocatalysts must possess several characteristics such as low overpotential, good electrocatalytic activity, high stability, and low production costs.

Direct synthesis of nanostructured catalysts on a conducting substrate may affect the performance of the resultant electrocatalysts because of their catalytic surface areas and the synergetic effect between the electrocatalyst and the conductive substrate. Nowadays three dimensional (3D) nickel foams have been utilized as electrode substrates due to their excellent mass transport, large active surface area and a highly conductive continuous 3D open-pore structure.

In this work, we discuss the most recent developments in nanostructured materials ( $\text{MO}_x/\text{OH}$ ,  $\text{MxCh}_y$ , where  $\text{M}=\text{Ni}$ ,  $\text{Co}$  and  $\text{Fe}$ ;  $\text{Ch}=\text{Se}$  and  $\text{S}$ ) directly synthesized on 3D nickel foam via "Deep Drying method"(DDM) and/or Hydrothermal (HT) synthesis as a potential electrode candidates for electrochemical water electrolysis, namely, the oxygen evolution reaction (OER) and the hydrogen evolution reaction (HER).

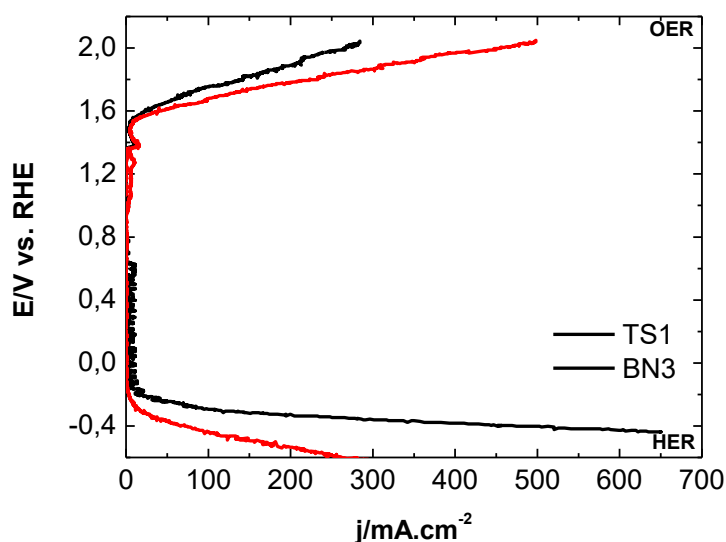

Figure 1. LSV curves of the TS1 and BN3 electrodes in 1 M KOH, scan rate  $1 \text{ mV}\cdot\text{s}^{-1}$

The as-prepared samples have been characterized by XRD, XPS and SEM. The corresponding OER and HER performances in alkaline media (1M KOH) have been systematically investigated.

$\text{CoFeO}_x/\text{NF}$  (BN3) and  $\text{CoNiFeO}_x$  (TS1) show bifunctional activity for HER and OER (Figure 1) and are potential candidates for the industrial application due to the achieved high current densities (over  $500 \text{ mA}\cdot\text{cm}^{-2}$ ).

**Acknowledgments:** Part of the experiments were performed with equipment included in the National Infrastructure NI SEVE supported by the Ministry of Education and Science under grant agreement № DO1-160/28.08.18. This research is supported by Bulgarian Academy of Science via program for career development of young scientists (Project number: DFNP-17-147/01.08.2017).

## Surface pinning of voids in electromigration testing by anodization of combinatorial Al-Cu alloys

Saeedeh Ravandi<sup>1,2</sup>, Tobias Zenger<sup>3</sup>, Martin Eibelhuber<sup>3</sup>, Achim Walter Hassel<sup>1</sup>, Andrei Ionut Mardare<sup>1</sup>

<sup>1</sup>Institute for Chemical Technology of Inorganic Materials, Johannes Kepler University Linz, Linz, Austria

<sup>2</sup>CEST Competence Center for Electrochemical Surface Technology, Wiener Neustadt, Austria

<sup>3</sup>EV Group E. Thallner GmbH, DI Erich Thallner Str. 1, 4782 St. Florian am Inn, Austria

[saeedeh.ravandi@cest.at](mailto:saeedeh.ravandi@cest.at)

Electronic products have been miniaturized rapidly while their functionality range is enhanced drastically. Small scaling metallic interconnections leads to the main cause of device failure by electromigration, which is defined as the slow and gradual displacement of metal atoms due to high electron flux densities. As a result, mass transport of the electrode material occurs in the direction of the electronic current flow. Voids are created near the cathode while hillock formation is observed near anode. The common use of conducting thin films for devices unavoidably leads to an increase in the current densities, hence shortening the device lifetime. The commonly accepted mechanism responsible for electromigration is based on increased mobility of the grain boundaries. Under high electron flux densities the surface grain boundaries migrate and voids nucleation occurs at the materials surface [1].

One of the most technically relevant alloys investigated for improving the electromigration resistance of interconnects is Al-Cu. In the present study a combinatorial approach was used for fabrication of Al-Cu thin film alloys by sputtering co-deposition. Photolithographical patterning of 2D test wires allowed a high throughput compositional screening of electromigration resistance [2]. Due to the valve metal nature of Al, the effect of electrochemical surface passivation on void formation and grain boundary mobility was studied for identifying alloys with improved electromigration resistance. The role of film structure on electromigration resistance and the effect of grain boundary crystallography on formation of voids and hillocks was also assessed. The crystallinity of Al-Cu thin films dominated their resistivity. Higher thin films crystallinity lead to improving the lifetime of each 2D wire during electromigration testing [3].

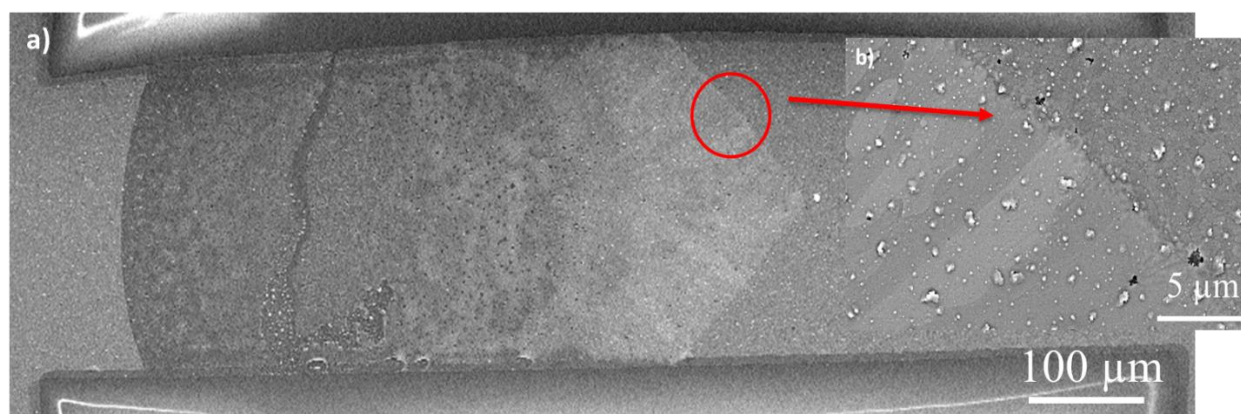

Figure 1. Change in surface morphology after electromigration: a) A 2D wire after EM test; b) Zoom-in of Al surface after electromigration test.

Investigation of failure zones (Figure 1a) revealed the combined effect of electron flux density (from left to right in the Figure) and charge carrier density gradient (vertical, from middle to the edges) on the Al-Cu grain boundaries (Figure 1b). Anodization resulted in a partial pin-down of voids at the cathodic side. Overall, a slight improvement of electromigration resistance was detected for anodic oxide thicknesses of 5.8nm.

### References

1. Y.W. Chang, Y. Cheng, F. Xu, L. Helfen, T. Tian, M.D. Michiel, C.Chen, K. N. Tu, T. Baumbach, *Acta Materialia* **117** (2017) 100-110 (<http://10.1038/s41598-017-06250-8>)
2. S. Ravandi, T. Zenger, M. Eibelhuber, A. W. Hassel, A. I. Mardare, *Phys Stat A* (submitted)
3. C.L. Liang, S.W. Lee, K.L. Lin, *Thin Solid Films*. **636** (2017) 164-170 (<https://doi.org/10.1016/j.tsf.2017.05.044>)

## Impact of elevated temperature on structural changes of perfluorosulfonated ionomer for polymer electrolyte membrane fuel cells

Anamarija Stoilova<sup>1,2,3</sup>, Matko Erceg<sup>2</sup>, Frano Barbir<sup>1,3</sup>

<sup>1</sup>Center of Excellence for Science and Technology – Integration of Mediterranean Region (STIM) at University of Split, Poljicka cesta 35, 21000 Split, Croatia [astoilov@fesb.hr](mailto:astoilov@fesb.hr)

<sup>2</sup>Faculty of Chemistry and Technology (KTF), University of Split, R Boskovicica 35, 21000 Split, Croatia

<sup>3</sup>Faculty of Electrical Engineering, Mechanical Engineering and Naval Architecture (FESB), University of Split, R Boskovicica 32, 21000 Split, Croatia

The electrochemical reactions in low-temperature polymer electrolyte membrane (PEM) fuel cells take place on the catalyst surface at the so-called triple phase boundary. These reactions, particularly on the cathode side, result in significant heat release. The temperature at this surface will correspond to an equilibrium between the heat release and heat removal rates, and can reach up to 20°C above the coolant temperature. Insufficient local heat removal may result in local high temperatures which may cause morphological changes in polymer electrolyte surrounding the reaction sites, which in turn may affect its proton conductivity thus resulting in fuel cell performance degradation. In order to better understand the fuel cell degradation phenomena, there is a strong need to fully understand thermal behaviour of the fuel cell materials, primarily the polymer electrolyte.

The thermal behaviour of Nafion<sup>TM</sup>, perfluorosulfonate ionomer, was studied by differential scanning calorimetry (DSC). The sample was Nafion<sup>TM</sup> 112, a 50 µm thick membrane. Due to the ionic nature of the membrane, Nafion<sup>TM</sup> stable structure can turn to an unstable state by heating, which should be visible on DSC curves in the form of an endothermic peak. Interchange of formation and disruption of the ionic clusters is caused by the thermoreversible characteristic of the intramolecular ionic interactions. Therefore, it is important after each heat treatment to leave a sample for a certain time while the bond is formed again. Otherwise, the peak on DSC curves would not have been visible if the DSC analysis had been repeated immediately after each treatment. In order to prove that, three measurements were performed on the same sample at previously set time intervals (initial, 3 days after and 7 days after). The obtained measurements showed that the first endothermic peak is apparent in the temperature range of 60-140 °C. While the most of the authors have overlapped this peak to the glass transition or evaporation of the residual water, we have attributed that peak to the ionic bonding. The second heat run, performed immediately after the first heat run, indicates suppression of the first peak. Remaining measurements were performed again after 3 and 7 days. Gradual peak increase was noticed, shifting peak to a higher temperature. Increasing the time interval between measurements, the ionic clusters arrange themselves, demanding more energy for their translation into the unstable state. It means higher endothermic peak and higher heat of transition, which is evident through the increase of enthalpy. The membrane structure, during the heat release, will not be affected by irreversible degradation due to its thermoreversible ionic interactions. Future work concerns the deeper analysis of thermal properties with focus on temperature distribution through the triple phase boundary of the PEM fuel cells.

**Fuel cells, a clean and efficient way of producing electricity:  
Brief description of the different types of fuel cells and their applications**

J. Tartaj

*Instituto de Cerámica y Vidrio (CSIC), Kelsen 5, 28049 Madrid, Spain*

Fuel cells (FCs) are energy conversion devices that produce electricity with high efficiency and negligible pollution. Other advantages such as multi-fuel capability, a modular construction design and environmental compatibility make them to be considered as one of the most promising future power generation devices. Every fuel cell has two electrodes, the cathode and anode. The reactions that produce electricity take place at the electrodes. The electrolyte, which carries electrically charged particles from one electrode to the other. Hydrogen is the basic fuel, but fuel cells also require oxygen. The type of fuel also depends on the electrolyte. The main electrolyte types are alkali, molten carbonate, phosphoric acid, proton exchange membrane (PEM) and solid oxide. The first three are liquid electrolytes; the last two are solids. Each type of fuel cell has advantages and drawbacks compared to the others, and none is yet cheap and efficient enough to widely replace traditional ways of generating power. However, great progress is being made both in the conventional fuel cells mentioned above, and in the development of new types and/or concepts such as regenerative and direct alcohol fuel cells, which are significantly improving their efficiency, cost of electricity production and, also allowing the use of alternative fuels to hydrogen such as methane. In this presentation we will briefly describe the different types of fuel cells, from the most conventional ones to the most recent developments and we will mention those applications in the production of stationary electricity, as well as in the transport in which they are acquiring significant notoriety.

## Monitoring and evaluation of polymer electrolyte fuel cells under harmful operating conditions

Mayer Kurt, Hacker Viktor

Institute of Chemical Engineering and Environmental Technologies, Graz University of Technology, Austria  
[kurt.mayer@tugraz.at](mailto:kurt.mayer@tugraz.at)

A challenging topic of current fuel cell research is the fast detection and identification of harmful operating conditions via in-situ online monitoring techniques in order to enhance the lifetime of fuel cells. Available techniques include electrochemical impedance spectroscopy (EIS), polarization curve measurements (PCM), cell voltage monitoring (CVM) as well as total harmonic distortion analysis (THDA).

EIS and PCM are conducted at steady-state operating points due to their time-invariance. This makes them slow and thus they cannot be used for transient investigations of the dynamic behaviour of an operating fuel cell. CVM is capable to monitor faulty operating conditions, but additional hardware has to be implemented in the fuel cell stack and this technique mostly lacks the ability to identify the cause of the fault [1].

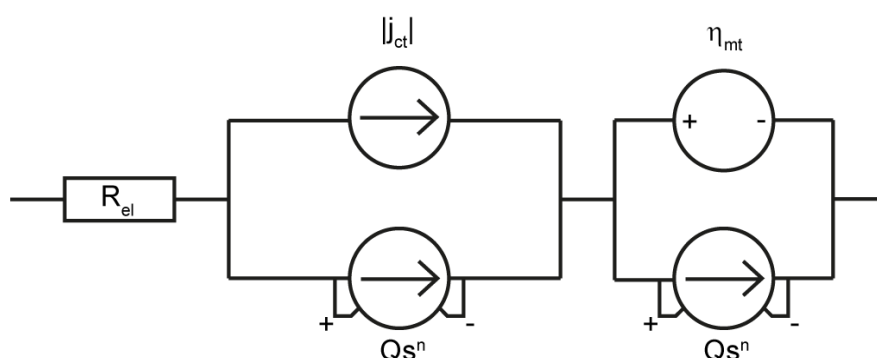

Figure 1: dLSEC;  $R_{el}$  - electrolyte resistance,  $j_{ct}$  - charge transfer current density (follows Butler-Volmer Equation),  $\eta_{mt}$  - mass transport overpotential (derived from Nernst Equation and Fick's Law),  $Qs^n$  - Laplace transform of constant phase element [2].

In this presentation, the build-up of a dynamic large signal equivalent circuit (dLSEC, see Figure 1) will be explained, that combines the data of small signal equivalent circuits (SSEC) derived from EIS measurements at different operating points with data from PCMs [2]. With the help of dLSECs, impedance spectra, polarization curves as well as THD spectra can be simulated. Experimental as well as simulated results of polarization curves, electrochemical impedance spectra and THD spectra will be shown for different harmful operating conditions like flooding and drying-out of the membrane. These investigations were carried out on either polymer electrolyte membrane fuel cell (PEMFC) short stacks or segmented single cells.

### References

1. E. Ramschak, V. Peinecke, P. Prenninger, T. Schaffer, V. Hacker, *Journal of Power Sources* **157** (2006) 837-840 (<https://dx.doi.org/10.1016/j.jpowsour.2006.01.009>)
2. S. Weinberger, S. Trattner, B. Cermenek, A. Schenk, C. Grimmer, V. Hacker, *Journal of Energy Storage* **12** (2017) 319-331 (<https://dx.doi.org/10.1016/j.est.2017.05.010>)

## Rejuvenation phenomena of proton exchange membrane fuel cells

Ivan Pivac<sup>1,2</sup>, Frano Barbir<sup>1,2</sup>, Jagoda Radošević<sup>1</sup>

<sup>1</sup>FESB, University of Split, R Boskovicica 32, 21000 Split, Croatia [ipivac@fesb.hr](mailto:ipivac@fesb.hr)

<sup>2</sup>Center of Excellence STIM, University of Split, Poljicka cesta 35, 21000 Split, Croatia

Degradation (*i.e.* voltage loss over time) of proton exchange membrane (PEM) fuel cell performance mainly refers to irreversible (also called permanent or unrecoverable) performance decay, which could be caused by several degradation mechanisms on various fuel cell components. However, when the fuel cell exploitation or its durability testing is intentionally or unintentionally interrupted, such as equipment maintenance, start-up/shutdown procedure, overnight rest, continuous electrochemical in situ testing, etc., a phenomenon of performance recovery could occur. Therefore, some degradation may be recoverable, also called temporary, reversible, regenerative, restorable, or transient performance degradation. The main reason for this recovery or rejuvenation phenomenon is often a result of transient processes, commonly attributed to non-ideal inner water and heat management, *i.e.* changes in the water balance of the fuel cell, where the loss in voltage may be reversed completely or partially by changing the operating conditions (or with the aid of some special in situ recovery procedure), and consequently the cell performance may return or at least it may come closer to pre-degraded levels. Therefore, the recoverable activity loss in diagnostics should be eliminated from the overall performance degradation or at least minimized in order to correctly evaluate the true performance degradation and to prevent premature failure due to the irreversible degradation. Unfortunately, the most accelerated stress test (AST) protocols, have no descriptions/consideration of the reversible losses or appropriate procedure to eliminate or recover the reversible losses.

The goal of this study is to present the impact of shutdown procedure and duration of the resting period on PEM fuel cell rejuvenation. An already conditioned standard 50 cm<sup>2</sup> (single) fuel cell was exposed to AST protocol consisting of voltage cycling, designed to target electrocatalyst degradation, but with the intentional recovery periods (so-called soak time steps) every 2500 voltage cycles. Before and after every intentional soak time, a series of diagnostic methods (namely polarization curves, electrochemical impedance spectroscopy, cyclic voltammetry, linear sweep voltammetry) were performed. Different shutdown procedures, as well as different duration of the soak time period were tested and their impact on performance recovery evaluated. The results suggest that cause of the reversible degradation could be accumulated water within the cell and/or presence of oxygen within the catalyst layer leading to formation of Pt oxides on the catalyst surface. The prolonged soak time step reduces recovery effect, while rapid reduction of the cell temperature with ice proved to be counterproductive for performance recovery. Shutdown procedure without shortly-connected resistor has shown no effect on recovery. Shutdown procedure without nitrogen purge proved to be the most effective for performance recovery.

## Design of polymer coated catalysts for enhanced oxygen reduction reaction toward durable polymer electrolyte fuel cells

Katharina Kocher, Viktor Hacker

<sup>1</sup>*Institute of Chemical Engineering and Environmental Technology, Graz University of Technology, Inffeldgasse 25/C, 8010 Graz, Austria*  
[katharina.kocher@tu-graz.at](mailto:katharina.kocher@tu-graz.at)

The oxygen reduction reaction (ORR) is a fundamental reaction related to various disciplines such as energy conversion, material dissolution or biology. In acidic low and high temperature polymer electrolyte fuel cells, hydrogen is oxidized into protons and electrons during the hydrogen oxidation reaction at the anode. Simultaneously, the ORR occurs at the cathode, whereby oxygen atoms from the surrounding air are reduced with protons [1].

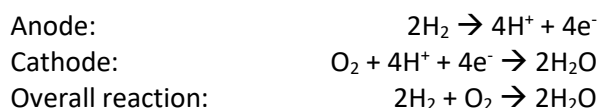

In practical application, due to the sluggish kinetics of the ORR, platinum and platinum based electrocatalysts are still the state-of-the-art cathodes to catalyse the ORR. However, the high overpotentials and the hazardous environment in the fuel cell cause catalyst degradation limiting its lifetime and durability. As depicted in Fig. 1, several key parameters are to be considered in order to develop highly active and stable cathode catalysts. The implementation of a polymer film based on the conduction polymer polyaniline (PANI) into the catalyst system (platinum dispersed on carbon, Pt/C), which exhibits high stability and catalytic activity, was investigated.

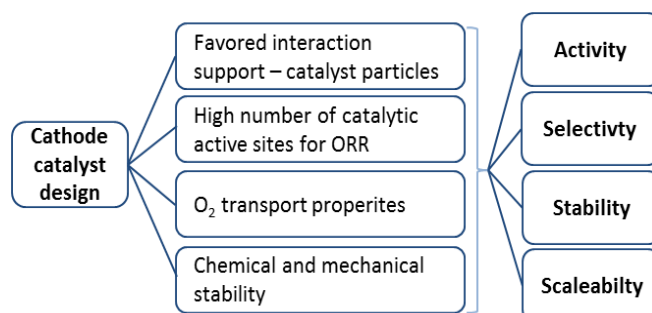

Fig. 1: Schematic of important parameters to obtain catalytically active and stable catalysts for ORR

For the catalyst preparation, a commercial Pt/C catalyst was selectively coated with a PANI layer via oxidative polymerization of aniline monomers [2,3]. Electrochemical characterization was carried out by means of rotating disk electrode technique performing cyclic voltammetry and ORR measurements in nitrogen and oxygen saturated perchloric acid electrolyte, respectively. Results of the coated catalyst showed a more than two times higher activity and higher stability compared to the uncoated equivalent.

### References

1. V. Hacker, S. Mitsushima, *Fuel Cell and Hydrogen-From Fundamentals to Applied Research*, (2018) (ISBN: 9780128115374)
2. S. Chen *et al.*, *J. Am. Chem. Soc.* **134** (2012) 13252–13255.
3. K. Kocher, V. Hacker, *4<sup>th</sup> International Workshop on Hydrogen and Fuel Cells*, TU Graz, 23.08.2018, p. 21-22.

## Reversibility in a new design of solid oxide fuel cell

Gergana Raikova, Blagoy Burdin, Emilia Mladenova, Milena Krapchanska, Daria Vladikova,  
Zdravko Stoynov

*Institute of Electrochemistry and Energy Systems - Bulgarian Academy of Sciences,  
10 Acad. G. Bonchev St., 1113 Sofia, Bulgaria  
[graikova@iees.bas.bg](mailto:graikova@iees.bas.bg)*

A promising direction in the development of high temperature fuel cells is the reversible approach in which the device operates as solid oxide fuel cell (SOFC) and as electrolyzer (SOEL), *i.e.* as an energy conversion/storage device. This mode of operation is very attractive for coupling with RES which usually require energy storage to meet specific power demands. SOEL and SOFC concepts are similar regarding materials and geometries. However, even if the systems are very close and can be operated in the same range of temperatures, optimum operation parameters may differ significantly, in particular in terms of current density, which is much higher in SOEL regime.

This work presents a new design of fuel cell, named “dual membrane fuel cell” (dmFC) [1]. The innovative conception is based on the geometrical separation of the water formation from both the anodic and the cathodic compartments, thus ensuring higher efficiency and overcoming many of the limitations of classical SOFC. The preparation of the “dual membrane”, *i.e.* central membrane (CM), which is the kernel of the system, from one single material BCY15 ( $\text{BaCe}_{0.85}\text{Y}_{0.15}\text{O}_{2.925}$ ) with mixed (proton and oxide ionic) conductivity, founded previously [2-5], advantages the cell fabrication and simplifies the chambers compatibility. The natural property of the BCY15 material to split water leads to the development of a Reversible Solid Oxide Cell (rSOC) based on the new design. The systematic studies of the central membrane of monolithic dmFC showed that 25-35% porosity could ensure an optimal microstructure in respect to conductivity, gas permeability and mechanical stability [6]. Important optimization parameter for the development of the new concept was the thickness of the CM. It has to guarantee smaller resistance combined with sufficient periphery for formation/injection of water. Since the CM works as chemical reactor, the density of the reaction triple phase boundaries in its volume should be sufficient. This work aims at optimization of the CM in respect to its thickness by electrochemical testing of a full dmFC configuration. Since the reaction in the CM involves the most active particles – protons and oxide ions, the influence of a catalyst in the water chamber is also examined. The results show that the combination of design and material brings to important principle advantages in respect to the classical rSOC – better performance in electrolyzer mode combined with instantaneous switching.

*Acknowledgements:* This work was supported by the Bulgarian Ministry of Education and Science under the National Research Programme E+: Low Carbon Energy for the Transport and Households, grant agreement D01-214/2018 and partially under the National Roadmap for Research Infrastructure (2017-2023): Research Infrastructure Energy Storage and Hydrogen Energetics NI SEVE, grant agreement D01-160/28.08.18

### References

1. Z. Stoynov, D. Vladikova, A. Thorel, A. Chesnaud, M. Viviani, A. Barbucci, Patent N ES2554456T3 (2011).
2. A. Thorel, Z. Stoynov, D. Vladikova, A. Chesnaud, M. Viviani, S. Presto, US Patent № 20120156573 (2012).
3. D. Vladikova, Z. Stoynov, G. Raikova, A. Thorel, A. Chesnaud, J. Abreu, M. Viviani, A. Barbucci, S. Presto, P. Carpanese, *Electrochimica Acta*, 56, 7955 (2011).
4. A. Thorel, J. Abreu, S. Ansar, A. Barbucci, T. Brylewski, A. Chesnaud, Z. Ilhan, P. Piccardo, J. Prazuch, S. Presto, K. Przybylski, D. Soysal, Z. Stoynov, M. Viviani, D. Vladikova, *J. Electrochem. Soc.*, 160, F360 (2013).
5. D. Vladikova, Z. Stoynov, A. Chesnaud, A. Thorel, M. Vivianu, A. Barbucci, G. Raikova, P. Carpanese, M. Krapchanska, E. Mladenova, *Int. J. Hydrogen Energy*, 39, 21561 (2014).
6. G. Raikova, K. Krezhov, I. Genov, A. Thorel, A. Chesnaud, T. Malakova, D. Vladikova, Z. Stoynov, *Bulgarian Chemical Communications*, 49 (Special Issue C), 162 (2017).

## Combinatorial bandgap tuning of niobium-based anodic oxides for visible light applications

Andrei Ionut Mardare<sup>1</sup>, Cezarina Cella Mardare<sup>1,2</sup>, Christoph Cobet<sup>3</sup>, Achim Walter Hassel<sup>1,2</sup>

<sup>1</sup>Institute for Chemical Technology of Inorganic Materials Johannes Kepler University Linz, Austria

<sup>2</sup>Christian Doppler Laboratory for Combinatorial Oxide Chemistry, Johannes Kepler University Linz, Austria

<sup>3</sup>Center of Surface and Nanoanalytics (ZONA), Johannes Kepler University Linz, Austria

[andrei.mardare@jku.at](mailto:andrei.mardare@jku.at)

Oxides with improved properties are continuously researched for key applications in various fields in materials science, chemistry and physics. A special attention is lately given to Nb, Ta and Ti oxides due to their promising capabilities of nanocomposite formation enhancing photocatalytic activities in electrochemical energy production and/or storage applications including highly relevant modern research topics such as CO<sub>2</sub> reduction or water splitting. Additionally, the strong tendency of replacing current techniques for development of oxide films by anodization processes (observed in device fabrication) provides a strong motivation for properties screening of combinatorial anodic oxides. Moreover, Nb, Ta and Ti are all valve metals, with the clear advantage of straightforward electrochemical oxide formation control for both compact and porous microstructure varieties.

Variable angle spectroscopic ellipsometry (VASE) is used in the present work for optical properties mapping of anodic oxides grown on wide spread Nb-Ta and Nb-Ti thin film combinatorial libraries. Using a co-sputtering technique, these libraries were deposited on SiO<sub>2</sub> substrates (borosilicate glass) for compatibility with future device integration. The microstructure of the Nb-based parent metal alloys was tuned by modifying the library deposition conditions in order to avoid compositionally induced microstructure dissimilarities between alloys. This allowed a simplified interpretation of the mixed oxides properties based on Tauc-Lorentz oscillators for data fitting.

The crystallographic mapping of both libraries allowed identification of relevant compositional thresholds where symmetry changes occur influencing the anodic oxide properties. Upon step-wise anodization up to 10 V vs SHE (see Figure) VASE was used to calculate the oxide thicknesses in order to map the oxide formation factors, the results being in good agreement with electrochemical data [1]. The mixed oxides showed absorption close to visible photon energies and presented indications that an in-depth compositional gradient may be present. Individual bandgaps of Nb-based mixed oxides were mapped as a function of composition and a non-linear behavior was identified. The deviation from the linear model predicted by the mixed matter theory when applied for calculating the metal alloys electronegativities was explained by an in-depth compositional gradient of the mixed oxides [2]. Surface enrichment of minority species in oxidized form triggered a depletion of that species at the metal/oxide interface shifting the metal alloys electronegativities in a non-linear manner [3, 4]. Compositional tuning of the parent metals revealed the possibility of mixed oxides bandgap tuning.

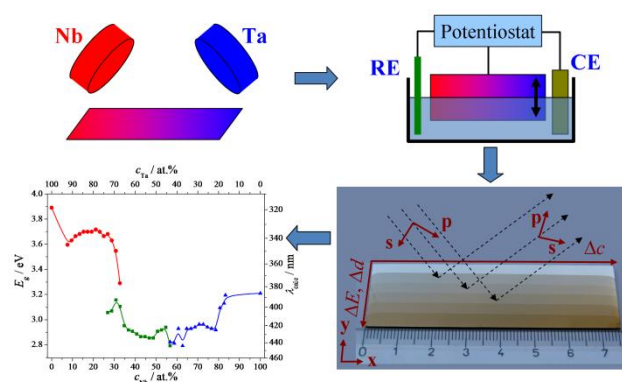

Combinatorial library formation, step-wise anodization and bandgap screening by spectroscopic ellipsometry of Nb-based anodic oxides.

### References

1. A.I. Mardare, A. Ludwig, A. Savan, A.W. Hassel, *Electrochim. Acta*, 140 (2014) 366–375
2. F. Di Franco, G. Zampardi, M. Santamaria, F. Di Quarto, H. Habazaki, *J. Electrochem. Soc.*, 159 (2012) C33-C39
3. W. Limberger, C.C. Mardare, C. Cobet, J. Zuo, A.W. Hassel, A.I. Mardare, *RSC Advances*, 6, (2016), 79934-79942
4. P. Bleckenwegner, C.C. Mardare, C. Cobet, J.P. Kollender, A.W. Hassel, A.I. Mardare, *ACS Combinatorial Science*, 19 (2017) 121-129

## Electrochemistry of macroscopic CVD-graphene on non-conducting substrates in deep eutectic solvents

Bernhard Gollas, David Fuchs, Bernhard C. Bayer<sup>1</sup>

*Institute for Chemistry and Technology of Materials, Graz University of Technology,  
Stremayrgasse 9, 8010 Graz, Austria*

<sup>1</sup>*Faculty of Physics, University of Vienna, Boltzmanngasse 5, 1090 Vienna, Austria  
[bernhard.gollas@tugraz.at](mailto:bernhard.gollas@tugraz.at)*

The publication of its facile production and outstanding properties [1] has sparked vast scientific interest in graphene and its possible applications. Up to now, the electrochemistry of graphene has been studied mainly in conventional aqueous and non-aqueous electrolytes [2]. There are few reports on the electrochemical behavior of graphene ion ionic liquids, but the electrochemistry of graphene in deep eutectic solvents is even less well studied. In this context, deep eutectic solvents have mainly been used for exploring the potential application of graphene in supercapacitors [3] and as electrolytes for the electrochemical exfoliation of graphene [4].

Deep eutectic solvents are described as ionic liquid-like fluids that share many of the beneficial properties of ionic liquids, but additionally being cheap and environmentally friendly [5]. Consequently, they have been suggested in many fields of application [6] including electroplating/metal processing, nanotechnology, organic synthesis, biomass processing, and electrochemical energy storage. For electrochemical applications and heterogeneous catalysis, a sound understanding of the interfacial behavior of deep eutectic solvents is necessary.

Due to the extensive knowledge of its properties, graphene could serve as an ideal model system for other carbon electrodes. The well-defined structure of CVD-graphene allows modelling of the interfacial properties more easily compared to less ordered graphite or glassy carbon electrodes [7]. However, it is essential to validate the resulting models against experimental data. We have thus studied the electrochemistry of CVD-graphene in the 1:2 mixture of choline chloride and ethylene glycol (12CE). The aim of this study was to establish the electrochemical potential window of CVD-graphene in 12CE and to compare its behavior to that of glassy carbon electrodes. We used CVD-graphene monolayers of macroscopic size transferred onto insulating silicon oxide covered Si wafers and electrically contacted them laterally in order to observe signals exclusively from graphene avoiding interference of any conductive support. We used the ferrocene/ferrocenium couple to characterize the electron transfer kinetics and correlated this to the defect density of the CVD-graphene, estimated from Raman spectra. The electrodeposition of zinc and germanium were used to explore the CVD-graphene behavior towards the cathodic potential limit of 12CE. Similarities, but also distinct differences between graphene and glassy carbon have been found for these phase formations [8].

*Acknowledgements:* B.G. and D.F. acknowledge support through the Competitive Initial Funding Programme in the Field of Expertise *Advanced Materials Science* of the Graz University of Technology. B.C.B. acknowledges funding from the European Union's Horizon 2020 research and innovation program under the Marie Skłodowska-Curie Grant Agreement 656214-2DInterFOX.

1. K. S. Novoselov, D. Jiang, F. Schedin, T. J. Booth, V. V. Khotkevich, S. V. Morozov, A. K. Geim, *Proc. Natl. Acad. Sci. USA* **102** (2005) 10451-10453.
2. D. A. C. Brownson, C. E. Banks, *Handbook of Graphene Electrochemistry*, Springer, London 2014.
3. Y. Ju, C. Lien, K. Chang, C. Hu, D.S. Wong, *J. Chin. Chem. Soc.* **59** (2012) 1280-1287.
4. A.M. Abdelkader, H.V. Patten, Z. Li, Y. Chen, I.A. Kinloch, *Nanoscale* **7** (2015) 11386-11392.
5. Q. Zhang, K. De Oliveira Vigier, S. Royer, F. Jérôme, *Chem. Soc. Rev.* **41** (2012) 7108-7146.
6. E.L. Smith, A.P. Abbott, K.S. Ryder, *Chem. Rev.* **114** (2014) 11060-11082.
7. S. Kaur, S. Sharma, H.K. Kashyap, *J. Chem. Phys.* **147** (2017) 194507.
8. B. Gollas, D. Fuchs, B. C. Bayer, manuscript in preparation.

## Electrodeposition of Sn binary and ternary alloys involving deep eutectic solvents

Liana Anicai<sup>1</sup>, Stefania Costovici<sup>1</sup>, Aurora Petica<sup>1</sup>, Sabrina Rosoiu<sup>1</sup>, Aida G. Pantazi<sup>1</sup>, Teodor Visan<sup>1,2</sup>

<sup>1</sup>Center of Surface Science and Nanotechnology, University Politehnica of Bucharest, Splaiul Independentei 313, Bucharest, 060042, Romania

<sup>2</sup>Department of Inorganic Chemistry, Physical Chemistry and Electrochemistry, University Politehnica of Bucharest, 132 Calea Grivitei, Bucharest, Romania, 010737, Bucharest, Romania  
[lanicai@itcnet.ro](mailto:lanicai@itcnet.ro)

As a result of the imposed restrictions on the use of hazardous materials by electronic industries, the development of lead-free solders including Sn-In, Sn-Ag-Cu, Sn-Ni-Cu alloys, attracted an increased interest. Electrodeposition represents a faster and cheaper route suitable to synthesize solder layers, with a great potential for scaling up to industrial level production. In addition, the use of electrolytes based on ionic liquids (ILs) and deep eutectic solvents (DESs) allows obtaining of a quite constant alloys composition which mainly depends on the metallic cations ratio, with no need for supplementary addition of surfactants, grain refiners and brighteners or oxidation inhibitors, as compared to classical water based electrolytes. This issue represents a significant advantage, especially when binary and ternary alloys are intended to be electrodeposited, thus providing an easier bath control.

Therefore, the paper presents some experimental results regarding the electrodeposition of Sn-In, Sn-Ag-Cu and Sn-Cu-Ni alloys from choline chloride-ethylene glycol (denoted ILEG) and choline chloride-malonic acid (denoted ILM) eutectic mixtures. The objective was to optimize the main operation parameters (*i.e.* the metallic ions mass ratio, the current form: direct or pulsed current, temperature) in order to achieve the corresponding alloy compositions able to possess the eutectic or near eutectic melting temperatures. Adherent and uniform Sn-In, Sn-Ag-Cu and Sn-Ni-Cu alloy deposits have been obtained exhibiting various morphologies depending on the applied operation parameters, mainly on the metallic species concentration and the current density (Fig.1).

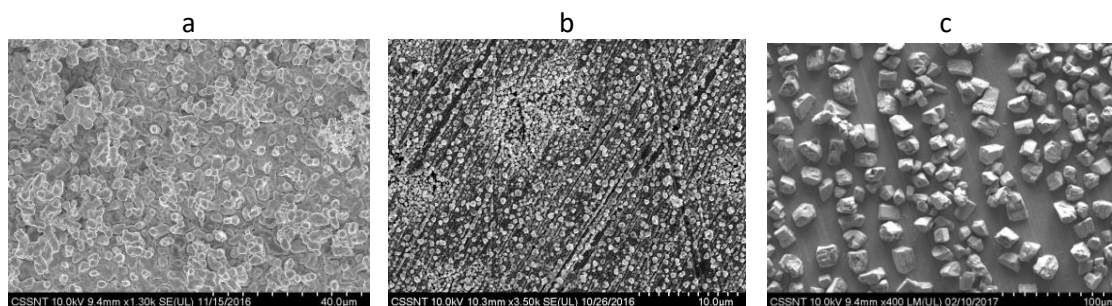

Fig. 1: SEM images of the electrodeposited Sn alloys on Cu substrates using ILEG based electrolytes: (a) Sn-In alloy, 2.5 mA/cm<sup>2</sup>, 45°C, 30 min.; (b) Sn-Ag-Cu alloy, 10 mA/cm<sup>2</sup>, 80°C, 30 min.; (c) Sn-Ni-Cu alloy, 10 mA/cm<sup>2</sup>, 70°C, 30 min.

The obtained results on the solderability performance, on the the risk of whisker formation involving the electronic industry standards (*i.e.* IPC TM 650 - Method 2.4.12, JEDEC 201: Environmental Acceptance requirements for Tin Whiskers Susceptibility of Tin and Tin Alloy Surface Finishes) as well as on corrosion performance are also reported. It should be noticed that no whiskers appearance was evidenced during the performed tests.

**Acknowledgements:** The work was supported by Romanian Ministry of Education and by Executive Agency for Higher Education, Research, Development and Innovation Funding, under NOVTINALBEST project 38/2016, M Era Net Program and under ROFCC project, Contract No. 25 PCCDI/2018. S.P. acknowledges the financial support under the Marie Skłodowska-Curie grant agreement No764977.

## An electrochemical process for the simultaneous purification of H<sub>2</sub>S and SO<sub>2</sub>

Dzhamal Uzun<sup>a</sup>, Elena Razkazova-Velkova<sup>b</sup>, Venko Beschkov<sup>b</sup>, Konstantin Petrov<sup>a</sup>

<sup>1)</sup>*Institute of Electrochemistry and Energy Systems „Acad. Evgeni Budevski”, Bulgarian Academy of Sciences, Acad. G. Bonchev Str., Bl.10, 1113 Sofia, Bulgaria*

<sup>2)</sup>*Institute of Chemical Engineering, Bulgarian Academy of Sciences, Acad. G. Bonchev Str., Bl. 103,1113 Sofia, Bulgaria*  
[kmavrodiev55@abv.bg](mailto:kmavrodiev55@abv.bg)

We propose a method for the simultaneous electrochemical extraction and purification of hydrogen sulfide and sulfur dioxide from sea water or industrial waste. More specifically, the treatment of industrial waste is mandatory, but present day technologies are very expensive and not yet very effective. The two reagents SO<sub>2</sub> and H<sub>2</sub>S are usually treated separately.

The purification of hydrogen sulfide is carried out utilizing the so called “Claus process”, in essence the process involves the oxidation of H<sub>2</sub>S with oxygen from the air. As well known, the chemical kinetics is dysfunctional at reagent concentrations of below 1.0%, in other words the chemical reactions proceed very slowly. Specialized catalysts and technologies are being sought to solve this problem. Common for both are the elevated temperatures.

The method proposed is aimed at the simultaneous purification of both reagents (SO<sub>2</sub> and H<sub>2</sub>S) at room temperatures. Fundamentally the method is based on the chemical affinity of both compounds. As known from classical chemistry the reaction of sulfur dioxide and hydrogen sulfide yields:



The method of sulfur extraction is based on the process, but this is not used in gas purification due to the partial conversion of the reagents and the contamination of the catalysts with sulfur. The method developed by us is based on the Claus reaction, but a specialized catalyst and technology are utilized and as a result it is not required to obtain sulfur, but poly-sulfides, sulfites and sulfates that do not poison the catalysts. The sulfates are ecologically acceptable. The catalysts are chelates of Co, Fe or perovskite deposited on teflonized high surface area carbons. The reactions mechanisms is electrochemical and occurs on distributed micro galvanic elements, possibly by way of the following reactions:



The method can be applied in alkaline, neutral or acidic media. As a result H<sub>2</sub>S and SO<sub>2</sub> are converted to concentrations of C<sub>H<sub>2</sub>S</sub> = 0 и C<sub>SO<sub>2</sub></sub> = 0.

The process may treat waste water or gases in a continuous mode within the reaction zone. Our vision is to apply the method to extract and convert the H<sub>2</sub>S found in the Black Sea waters while also converting the SO<sub>2</sub> into sulfur (a commercial product) by thermal power plants placed along the Black Sea coast. The best location for such an installation is the coast of Turkey, where a depth of 1000 m (C<sub>H<sub>2</sub>S</sub>=10 mg l<sup>-1</sup>) is found very close to the shore.

# **Corrosion Science and Protection**

## The effect of pre-treatment on the surface chemistry and interfacial properties of sol-gel coating applied on aluminium and aluminium alloys

Urša Tiringner<sup>1,2</sup>, Janez Kovač<sup>2</sup>, Shoshan Abrahami<sup>3</sup>, Joost van Dam<sup>1</sup>, Ingrid Milošev<sup>2</sup>, Arjan Mol<sup>1</sup>

<sup>1</sup>Delft University of Technology, Mekelweg 2, 2628 CD Delft, the Netherlands

<sup>2</sup>Jožef Stefan Institute, Jamova c. 39, SI-1000 Ljubljana, Slovenia

<sup>3</sup>Vrije Universiteit Brussel, Research Group Electrochemical and Surface Engineering.

Pleinlaan 2, 1050 Brussels, Belgium

[U.Tiringner-1@tudelft.nl](mailto:U.Tiringner-1@tudelft.nl)

Hybrid sol-gel coatings are one of the most promising environmentally friendly replacements for chromate conversion coatings (1). However, there is still a lack of understanding the importance of pre-treatments of substrate on coating deposition. The goal of this study was to improve the understanding of the effect of different pre-treatments of aluminium (Al) and aluminium alloys (AA7075 and AA2024) on adhesion with hybrid sol-gel coating. Hybrid sol-gel coatings, used in the present study, are based on (3-glycidylxypropyl)trimethoxysilane (GPTMS), tetraethyl orthosilicate (TEOS) and SiO<sub>2</sub> nanoparticles (denoted GTS) (2) and were deposited on differently pre-treated Al, AA7075 and AA2024.

According to earlier studies, more OH<sup>-</sup> groups result in stronger bonding between Al and the silicone from hybrid sol-gel coatings, resulting in better adhesion (1). For that purpose, different pre-treatments, alkaline (KOH), acidic (HNO<sub>3</sub>) and pseudoboehmite (DI boiling water), were used to control the formation of well-defined oxide layers with different hydroxyl fractions, prior to sol-gel coating deposition. Earlier studies showed the higher OH<sup>-</sup> fraction on AA6014, after pseudoboehmite pre-treatment (3).

Preliminary results from XPS and ToF-SIMS analysis confirm that pre-treatment has a significant effect on the quantity of OH<sup>-</sup> groups on Al, AA7075 and AA2024.

Potentiodynamic polarization curves of the different pre-treated substrates were measured in 0.1 M NaCl to study the effect of pre-treatment conditions on the subsequent electrochemical behaviour. Surface roughness and water contact angles of the differently pre-treated surfaces were measured to assess the effect on the adhesion. Early results show a good correlation with the OH<sup>-</sup> fraction, determined by ToF-SIMS and XPS analysis, and the wetting behaviour of the substrates. The morphology and composition of substrates after different pre-treatments were analysed using SEM-EDS analysis. Surface compositional maps were recorded to obtain the elemental distribution after different pre-treatments. A higher hydroxyl fraction is observed after acidic treatment unlike previous findings on different aluminium alloys (3) and the explanation of this is still in progress.

Furthermore, dry and wet adhesion between differently pre-treated substrates and GTS sol-gel coating are determined with pull-off tests. Finally, the effect of sol-gel coating on the dry and wet adhesion of overlaying epoxy-based organic coating, is studied using pull off tests and the delamination kinetics of this topcoat on pre-treated GTS sol-gel coating is measured using scanning Kelvin probe (SKP).

The financial support was provided by the European Union's Horizon 2020 research and innovation programme under the Marie Skłodowska-Curie grant agreement No. 707404.

### References

1. R. B. Figueira, C. J. R. Silva, E. V. Pereira, *Journal of coating technology and research* **12** (2015) 1-35 (<http://link.springer.com/article/10.1007/s11998-014-9595-6>)
2. U. Tiringner, A. Durán, Y. Castro, I. Milošev, *Journal of the electrochemical society* **165** (2018) C213-C225 (<http://jes.ecsdl.org/content/165/5/C213>)
3. J. Cerezo, P. Taheri, I. Vandendael, R. Posner, K. Lill, J. H. W. de Wit, J. M. C. Mol, H. Terryn, *Surface and coatings technology* **254** (2014) 277-283 (<https://doi.org/10.1016/j.surfcoat.2014.06.030>)

## Sol-gel spray and electrophoretic deposition techniques to enhance bioactive and antibacterial response of titanium implants

Josefina Ballarre, Tuba Ademir<sup>1</sup>, Liliana Liverani<sup>1</sup>, Aldo R. Boccaccini<sup>1</sup>

*Applied Electrochemistry Div.-INTEMA, CONICET-UNMDP, Inst. for Biomaterials – FAU-Erlangen Nuremberg*

<sup>1</sup> *Inst. for Biomaterials – FAU-Erlangen Nuremberg*

[jballarre@fi.mdp.edu.ar](mailto:jballarre@fi.mdp.edu.ar)

Compared to stainless steel 316L, titanium and its alloys generally proves a better tolerance for stress loading and fatigue as for permanent implant materials [1]. Cemented and cementless prosthesis are used in orthopaedic surgery and there is a vast discussion about advantages and disadvantages related with the loss of healthy bone tissue and use of acrylic cement. In this context the improvement of the osseointegration and the prevention of infections is a challenge to face in cementless implants. One promising technique is Electrophoretic deposition (EPD)[2]. The aim of this work is to develop a multifunctional and dual surface coating system for permanent titanium orthopedic implants by applying two different cost-effective, scalable and non-complex coating technologies. The first deposit is a sprayed hybrid sol-gel layer with bioactive particles (45S5 Bioglass) and the outer coating consists in a biopolymer/silica-antibiotic composite layer applied by electrophoretic deposition (EPD).

The first layer was applied by spray technique at room temperature on Ti grade 2 polished substrates. The sol was made by sol-gel synthesis of Tetraethoxysilane and Methyl triethoxysilane in acidic catalysis. Bioglass particles of 4 microns diameter were suspended in the sol in 10%w/w. The deposition was intended to generate drops of bioactive spots. The upper layer was made by EPD with constant voltage. The solution was a biopolymer mixture of chitosan and gelatin with ethanol as media. Also silica-gentamicin nanoparticles (Si-Ge np) were added to the EPD solution. Coatings were characterized by SEM, XRD, FTIR, contact angle and roughness tests. In vitro tests were carried on to analyze system degradation, antibiotics release and apatite formation. Also cellular and antibacterial tests were held on to determine the cell attachment and bacterial inhibition of the generated composite coatings.

EPD coatings were uniform and adapted to the sprayed substrate. After 7 days of immersion almost 80% of gentamicin was released but the bioglass components were being released slower. After 14 days of immersion there were clear hydroxyapatite deposits present. This was confirmed by the cell attachment and proliferation after 7 days. The antibacterial effect was evidenced at 24hs with a big inhibition halo circle around composite coated samples compare with bare ones.

The proposed composite system has promising advantageous properties to enhance bone formation and avoid bacterial adhesion of permanent titanium implants.

### References

1. P. Prasad, O. Bazaka, M. Chua, M. Rochford, L. Federick, J. Spoor, R. Symes, M. Tieppo, C. Collins, A. Cao, D. Markwell, K. Ostrikov, K. Bazaka, *Materials*, **10**(2017), 1-33.
2. A.R. Boccaccini, S. Keim, R. Ma, Y. Li, I. Zhitomirsky, *J R Soc Interface*, **7**(2010), 581–613.

## Hybrid sol-gel coatings modified with fluorinated (meth)acrylates for corrosion protection of AA2024-T3 in 0.5 M NaCl

Peter Rodič, Dolores Zimerl, Ingrid Milošev

Jožef Stefan Institute, Jamova cesta 39, 1000 Ljubljana, Slovenia

[peter.rodic@ijs.si](mailto:peter.rodic@ijs.si)

AA2024-T3 holds an important position in the aircraft industry due to superior physical and mechanical properties. However, if this alloy is subjected to some harsh environment such as  $\text{Cl}^-$  containing solution, it is prone to corrosion. Therefore, it is crucial to improve this drawback with additional corrosion protection. One of the options is applying hybrid sol-gel coating on alloy surface. Moreover, this system can also be used to obtain a superhydrophobic surface, where the water contact angle is greater than  $150^\circ$  and a sliding angle less than  $10^\circ$  [1]. Such surface characteristics have attracted tremendous attention over the last decade in both academic and industrial areas because modified surface often show self-cleaning and anti-icing properties [2]. Nowadays the research on the superhydrophobic surface has been mainly focused on coatings containing fluorochemicals with a C–F bond, because these finds applications in many fields, recently also in barrier corrosion protection [3].

In this work we focused on the synthesis of hybrid sol-gel coating from tetraethyl orthosilicate TEOS, 3-(trimethoxysilyl)propyl methacrylate MAPTMS and methyl methacrylate MMA. Primary sol was modified with fluorinated (meth)acrylates with various chain lengths to investigate the effect of C–F group on hydrophobicity and corrosion resistance.

The corrosion characterisation was performed using electrochemical impedance spectroscopy (EIS) and salt spray test according to the ASTM B117-07A standard. The surface characterisation was performed using contact profilometer, scanning electron microscopy, IR spectroscopy and contact angle tensiometer.

Prepared coatings exhibit highly hydrophobic characteristics with self-cleaning effect, superior anti-icing behaviour and efficient long-term corrosion-resistance.

### References:

1. G. Barati Darband, M. Aliofkhazraei, S. Khorsand, S. Sokhanvar, A. Kaboli, *Arabian Journal of Chemistry* In Press (2018) (<https://doi:10.1016/j.arabjc.2018.01.013>).
2. S. Pan, N. Wang, D. Xiong, Y. Deng, Y. Shi, *Applied Surface Science* **389** (2016) 547-553 (<https://doi:10.1016/j.apsusc.2016.07.138>).
3. W. Yao, Y. Li, X. Huang, *Polymer* **55** (2014) 6197-6211 (<https://doi:10.1016/j.polymer.2014.09.036>).

## Al<sub>2</sub>O<sub>3</sub> and HfO<sub>2</sub> films prepared by atomic layer deposition for protection of commercially pure titanium for biomedical applications

Ivan Spajić<sup>1,2</sup>, Ingrid Milošev<sup>1</sup>

<sup>1</sup>Jožef Stefan Institute, Jamova c. 39, SI-1000 Ljubljana, Slovenia

<sup>2</sup>Jožef Stefan International Postgraduate School, Jamova c. 39, SI-1000 Ljubljana, Slovenia

[ivan.spajic@ijs.si](mailto:ivan.spajic@ijs.si)

Titanium-based alloys are one of the most important materials used for manufacture of biomedical implant devices. In order to additionally protect metals subjected to physiological conditions, different strategies have been employed [1-3]. Atomic layer deposition (ALD) is a novel method for deposition of ultrathin barrier films [4]. In this study we focused on the deposition of Al<sub>2</sub>O<sub>3</sub> and HfO<sub>2</sub> films on commercially pure titanium (CP-Ti) to explore their effect on corrosion properties. Specifically, the effect of sample preparation prior the deposition on the barrier properties of these oxides was investigated.

ALD deposition was performed using a trimethylaluminium as a precursor for Al<sub>2</sub>O<sub>3</sub>, and tetrakis(ethylmethylamido)hafnium(IV) as a precursor for HfO<sub>2</sub> films. The film thickness was around 100 nm. CP-Ti samples were prepared in two different ways: (i) grinding using 500-grit SiC emery papers and (ii) grinding followed by polishing using silica suspension. Chemical composition was analysed using Time-of-Flight Secondary Ion Mass Spectrometry (ToF-SIMS) and Energy-dispersive X-ray spectroscopy analysis (EDS) using focused ion-beam system (FIB). Thickness and roughness were measured using ellipsometry and contact profilometer, respectively. Electrochemical measurements were carried out in Hanks' physiological solution at 37 °C [1-3]. According to potentiodynamic (PD) measurements, both Al<sub>2</sub>O<sub>3</sub> and HfO<sub>2</sub> ALD-coated CP-Ti samples have for ca. 6 orders of magnitude lower current density in the passive region than bare CP-Ti. Better barrier properties were noticed when films were deposited onto polished surface. ALD films deposited on rough surfaces tend to be somewhat thicker, less uniform and are likely to have a higher porosity and lower capacitance [4].

Electrochemical impedance spectroscopy (EIS) measurements show that ALD Al<sub>2</sub>O<sub>3</sub> and HfO<sub>2</sub> films on CP-Ti increase impedance values at low frequencies from ca. 10<sup>6</sup> to ca. 10<sup>8</sup> Ω·cm<sup>2</sup> for ground ALD-coated samples after 1h immersion in electrolyte. Similar to PD results, polished ALD-coated samples show larger increase in impedance values at low frequencies, *i.e.* ca. 10<sup>9</sup> Ω·cm<sup>2</sup> after 1h immersion, for both films. Additionally, these coatings retain their good barrier properties very well and even after 4 months immersion there is no changes in impedance and phase angle values. Ground ALD-coated samples show similar EIS behaviour as bare CP-Ti, *i.e.* spontaneous formation of passive layer of TiO<sub>2</sub> during immersion in electrolyte which indicates the porosity of the film or incomplete coverage of rough ground surface of CP-Ti. Films deposited on polished surface exhibit higher capacitive character than the films deposited on ground surface.

Corrosion protection of CP-Ti coated by ALD Al<sub>2</sub>O<sub>3</sub> and HfO<sub>2</sub> films proved to be very effective resulting in reducing the current density in the passive region and increasing the impedance values at low frequencies; however, only ALD films deposited on polished surfaces exhibit excellent protective ability even after extended exposure under corrosive conditions.

*Acknowledgment:* This project has received funding from the European Union's Horizon H2020 research and innovation programme under the Marie Skłodowska Curie grant agreement No. 764977.

### References

1. I. Milošev, *Pure and Applied Chemistry* **83** (2011) 309-324 (<https://doi.org/10.1351/PAC-CON-10-07-09>)
2. H. Wang, R. Zhang, Z. Yuan, X. Shu, E. Liu, Z. Han, *Ceramics International* **41** (2015) 11844-11851 (<http://dx.doi.org/10.1016/j.ceramint.2015.05.153>)
3. V. A. Alves, R. Q. Reis, I. C. B. Santos, D. G. Souza, T. de F. Gonçalves, M. A. Pereira-da-Silva, A. Rossi, L. A. da Silva, *Corrosion Science* **51** (2009) 2473-2482 (<https://doi.org/10.1016/j.corsci.2009.06.035>)
4. J. S. Daubert, G. T. Hill, H. N. Gotsch, A. P. Gremaud, J. S. Ovental, P. S. Williams, C. J. Oldham, G. N. Parsons, *ACS Appl. Mater. Interfaces* **9** (2017) 4192-4201 (<https://pubs.acs.org/doi/10.1021/acsami.6b13571>)

## Functionalization of titanium dioxide coatings for biomedical applications – corrosion impact study

Barbara Burnat, Andrzej Leniart, Sławomira Skrzypek

University of Lodz, Faculty of Chemistry, 12 Tamka St., 91-403 Lodz, Poland

[barbara.burnat@chemia.uni.lodz.pl](mailto:barbara.burnat@chemia.uni.lodz.pl)

Biomaterials as materials implanted into a living system must fulfill stringent requirements. Nowadays, studies on biomaterials are focused on enhancing their bioactivity and giving them new properties, *e.g.* antibacterial properties. One of the methods used for preparation of biomaterials with desirable properties is coating their surfaces with functionalized coatings. For example bioactivity may be enhanced by ion doping procedure – the coating is doped with metal ions *e.g.* calcium and strontium ions. The antibacterial properties may be also achieved by doping procedure – for that purpose silver, copper, zinc or gallium ions are used as antibacterial agent. Another method involves silver nanoparticles deposition. Unfortunately, every performed functionalization may cause deterioration of other features of biomaterials. Therefore, it is important to control the impact of carried out modifications on other material features, especially corrosion resistance. However, analysis of the available literature shows that there is little such information.

The main goal of this study was to apply sol-gel method for the preparation of protective ceramic coatings of titanium dioxide and their modification by doping of calcium, silver and copper ions. Moreover the photoactivity of titanium dioxide coatings was used for silver nanoparticles deposition.

The phase composition, thickness, morphology, topography and roughness of TiO<sub>2</sub>-based coatings were investigated using X-ray diffraction (XRD), X-ray reflectivity (XRR), scanning electron microscopy (SEM) and atomic force microscopy (AFM). The corrosion measurements were carried out in Phosphate Buffered Saline (PBS) solution using electrochemical methods. Anticorrosion properties of TiO<sub>2</sub>-based coatings were specified on the basis of determined values for corrosion potential  $E_{cor}$ , polarization resistance  $R_p$ , corrosion rate CR, current density in passive range and also breakdown  $E_b$  and repassivation  $E_{rep}$  potentials.

The sol-gel procedure and annealing temperature of 450 °C applied in this study allowed the synthesis of crystalline TiO<sub>2</sub> coating with a thickness of ca. 70 nm. Using sol-gel procedure the TiO<sub>2</sub> coating was successfully functionalized by doping of calcium, silver and copper ions. Depending on doped ion the surface morphology of the coating was different. The crystalline form of anatase allow to obtain the silver nanoparticles in photochemical process. The amount, size and morphology of these nanoparticles is dependent on the precursor concentration and time of UV irradiation. The results of corrosion tests in PBS solution confirmed the anticorrosion properties of all TiO<sub>2</sub>-based coatings.

## Improving the anticorrosive properties of chitosan coatings by impregnation with inhibitors

Árpád Ferenc Szőke<sup>1</sup>, Gabriella Stefánia Szabó<sup>1</sup>, Zoltán Hórvölgyi<sup>2</sup>, Emőke Albert<sup>2</sup>, Liana Maria Muresan<sup>1</sup>

<sup>1</sup>Babeş-Bolyai University, Faculty of Chemistry and Chemical Engineering, Romania, RO-400028, Cluj-Napoca, 11 Arany János St, Romania

<sup>2</sup>Budapest University of Technology and Economics, Faculty of Chemical Technology and Biotechnology, HU-1111, Budapest, Budafoki út 6-8, Hungary  
[szokearpad@chem.ubbcluj.ro](mailto:szokearpad@chem.ubbcluj.ro)

Polymeric coatings offer a versatile alternative in corrosion prevention. The incorporation of inhibitors or structural modifications can greatly increase their anticorrosive effect [1,2].

Chitosan (Chit) is an environmentally friendly polymer that is available in abundance. Its solubility in acids makes it easy to process, however due to its low barrier properties, native chitosan coatings have only modest anticorrosive effects. This effect can be greatly improved through the incorporation of inhibitors that affect the coating by reducing permeability through ionic crosslinking [2] or the metal surface directly, reducing the rate of corrosion [3]. Due to the polycationic and porous nature of chitosan, impregnating agents can accumulate extremely well in its polymer matrix.

In this study, thin chitosan coatings were applied to zinc substrates by dip-coating technique. To improve anticorrosive properties, the chitosan was impregnated with a known inhibitor, 2-acetyl-amino-5-mercapto-1,3,4-thiadiazole (AMT) and two different ionic crosslinking agents, indigo carmine (IC) and ammonium paratungstate (PTA). The native and doped chitosan coatings were characterized by wettability, SEM, EDS and UV-Vis spectroscopy measurements. The anticorrosive effect of the different films was assessed by potentiodynamic polarization and electrochemical impedance spectroscopy (EIS) studies.

Results show a good accumulation (up to 2500X) of all impregnating agents. All inhibitors achieved high anticorrosive efficiencies (>90 %). However, it should be mentioned that the high ionic valence of PTA can have a detrimental effect on the structural integrity of chitosan by producing cracks due to a more rigid structure of the polymer matrix.

The Chit-IC system can be a good, eco-friendly alternative in temporary protection of zinc, removable on demand without damaging the underlying substrate.

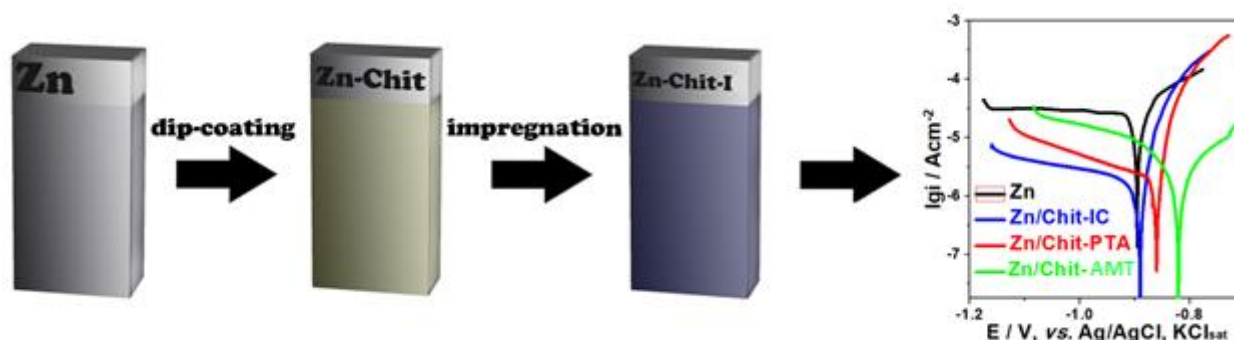

Figure 1 : Preparation of impregnated chitosan coatings (Chit-I) on zinc and subsequent electrochemical study

### References

1. L. Y. Pozzo, T. F. Conceição, A. Spinelli, N. Scharnagl, A. T. N. Pires, *Carbohydrate Polymers*, **181** (2018), 71–77. (<http://dx.doi.org/10.1016/j.carbpol.2017.10.055>)
2. J. Berger, M. Reist, J. M. Mayer, O. Felt, N. A. Peppas, R. Gurny, *European Journal of Pharmaceutics and Biopharmaceutics*, **57** (2004), 19–34. ([https://doi.org/10.1016/S0939-6411\(03\)00161-9](https://doi.org/10.1016/S0939-6411(03)00161-9))
3. J. Carneiro, J. Tedim, S.C. M. Fernandes, C. S. R. Freire, A. Gandini, M. G. S. Ferreira, M. L. Zheludkevicha, *ECS Electrochemistry Letters*, **2:6** (2013), C19-C22. (<https://doi.org/10.1149/2.002306eel>)

## The influence of surface preparation on efficiency of mercapto and phosphonic inhibitors adsorbed on aluminium and copper metal

Dževad K. Kozlica<sup>1,2</sup>, Ingrid Milošev<sup>1</sup>

<sup>1</sup>Jožef Stefan Institute, Department of Physical and Organic Chemistry, Jamova c. 39, 1000 Ljubljana, Slovenia

<sup>2</sup>Jožef Stefan International Postgraduate School, Jamova c. 39, 1000 Ljubljana, Slovenia  
[dzevad.kozlica@ijs.si](mailto:dzevad.kozlica@ijs.si)

Corrosion is an electrochemical phenomenon with enormous economic impact on the society. To reduce corrosion, different strategies are being used to protect metallic materials. These strategies comprise various metallic, inorganic and oxide coatings and paints, as well as corrosion inhibitors. Corrosion inhibitors are compounds which added in small amount retard the rate of anodic and/or cathodic corrosion reaction [1]. Efficiency of corrosion protection using inhibitors is dependent on the chemical structure of the inhibitor compound but also on the type of metal substrate, as well as its appropriate surface preparation [1,2].

We have chosen two inhibitors, 2-mercaptobenzimidazole and octylphosphonic acid, which may differ in their affinity for different metals. In order to understand the corrosion processes occurring on the surface of an alloy, it is of great importance to explore separately the contribution of individual metals. In the present work we focused on aluminum and copper as main constituents of important aluminium alloys used in many industrial applications.

The selection of appropriate pretreatment method plays a significant role in the morphology, microstructure and composition of the surface to be subjected to further treatment; therefore also corrosion properties may be affected [3]. To investigate this issue further, we tested different pretreatments including mechanical and chemical pretreatment of alkaline etching and acid desmutting. Inhibitors were added either directly in aqueous solution or prepared by immersion in a non-aqueous inhibitor containing solution.

Electrochemical measurements revealed the differences in the mechanism of inhibitory action of the compounds regarding the type and preparation of substrate. The efficiency of mercapto and phosphonate corrosion inhibitors is correlated to surface composition, wettability and roughness of the metal surface verified by ATR-FTIR, SEM/EDS, XPS, water contact angle and 3D-profilometry measurements.

*Acknowledgment:* The PhD scholarship for Dž.K.K. by Ad Futura through Public scholarship, development, disability, and maintenance fund of Republic of Slovenia is acknowledged.

### References:

1. Sastri, V. S. (2012). *Green corrosion inhibitors: theory and practice* (Vol. 10). John Wiley & Sons.
2. Milošev, I., Kovačević, N., Kovač, J., & Kokalj, A. (2015). The roles of mercapto, benzene and methyl groups in the corrosion inhibition of imidazoles on copper: I. Experimental characterization. *Corrosion Science*, 98, 107-118. (<https://doi.org/10.1016/j.corsci.2015.05.006>)
3. Hu, S., Chen, Z., & Guo, X. (2018). Inhibition Effect of Three-Dimensional (3D) Nanostructures on the Corrosion Resistance of 1-Dodecanethiol Self-Assembled Monolayer on Copper in NaCl Solution. *Materials*, 11(7), 1225. ([doi: 10.3390/ma11071225](https://doi.org/10.3390/ma11071225).)

## Testing inorganic ions as “green” corrosion inhibitors for construction steel

Francisco Montes, Lucía Yohai, Marcela Vazquez, María B. Valcarce

INTEMA, UNMDP-CONICET, Colón 10850, (7600) Mar del Plata, Argentina

[mvazquez@fi.mdp.edu.ar](mailto:mvazquez@fi.mdp.edu.ar)

Reinforced concrete is a reliable building material due to many excellent properties such as strength and durability. Marine environments and chloride-contaminated aggregates accelerate deterioration and failure<sup>[1]</sup>. Inhibitors are frequently considered to mitigate steel corrosion<sup>[2]</sup>. Nitrite ions are effective corrosion inhibitors but there are environmental concerns associated to their use<sup>[3]</sup>. Sodium phosphate ( $\text{Na}_3\text{PO}_4$ )<sup>[4]</sup> and sodium silicate ( $\text{Na}_2\text{SiO}_3$ ) are tested as alternatives of interest. The evaluation is carried out in a solution that simulates the composition of the pores in chloride-contaminated concrete. The inhibitor concentration is 0.3 mol/L and the pH of the synthetic medium that simulates contaminated concrete is 13 (PSS), while the inhibitor/chloride ratio is 1.

Anodic polarization curves and weight-loss test are complemented with micro-Raman spectroscopy to evaluate the surface film composition in different corrosion stages. The electrodes were stabilized for 24 h at open circuit potential (OCP).

It is well-known that chloride contamination promotes active corrosion. When phosphate ions are incorporated, pitting is inhibited even if the OCP moves toward slightly more negative values. The composition of the surface layer changes when phosphates are present. Raman spectra show a broad band, centered in  $982\text{ cm}^{-1}$ , suggesting that phosphates incorporate to the passive film. Even after 90 days at open circuit potential weight loss is minimal. Phosphates are also present in the corrosion products.

The presence of silicate ion inhibits the localized corrosion, even polarizing to potentials close  $0.6\text{ V}_{\text{MOE}}$ . The passive current decreases markedly when compared to the uninhibited solution. As for phosphates, long term exposures show minimal weight loss when silicates are present. Silicate ions are not readily detectable by Raman spectroscopy, since the bands appear superimposed with others originated in the passive film.

Relevant parameters associated to pitting corrosion are shown in table 1.

It can be concluded that phosphate and silicate ions are good candidates to be used as green corrosion inhibitors for steel in chloride-contaminated concrete.

Table 1: Comparison of electrochemical parameters when phosphate or silicate ions are present. Potential values are evaluated with Hg/HgO/KOH  $1\text{ mol L}^{-1}$  as reference electrode (MOE,  $E = 0.123\text{ V}$  vs. SHE)

	OCP, $\text{mV}_{\text{MOE}}$	$E_{\text{PIT}}/\text{mV}_{\text{MOE}}$	$E_{\text{PIT-OCP}}$ , mV	$i_{\text{PAS}}/\mu\text{A cm}^{-2}$
PSS + $\text{Cl}^-$	$-237 \pm 30$	$-263 \pm 34$	$182 \pm 81$	$5.4 \pm 2.6$
PSS + $[\text{PO}_4^{3-}]/[\text{Cl}^-]=1$	$-263 \pm 34$	No pitting		$0.3 \pm 0.12$
PSS + $[\text{SiO}_3^{2-}]/[\text{Cl}^-]=1$	$-328 \pm 59$	No pitting		$1.3 \pm 0.7$

### References

1. K. Y. Ann and H.-W. Song, Corrosion Science **49** (2007) 4113
2. T. A. Söylev and M. G. Richardson, Construction and Building Materials **22** (2008) 609
3. M. B. Valcarce and M. Vázquez, Electrochimica Acta **53** (2008) 5007
4. L. Yohai, M. Vázquez and M. B. Valcarce, Electrochimica Acta **102** (2013) 88

## Metal surface microstructure and inhibitor performance

Emeka E. Oguzie<sup>1,2,3</sup>, Lui Li<sup>2,3</sup>, Maduabuchi A. Chidiebere<sup>1</sup>, Pan Chen<sup>2</sup>, Ying Li<sup>2</sup>, Fuhui Wang<sup>2,3</sup>

<sup>1</sup>*Africa Centre of Excellence in Future Energies and Electrochemical Systems (ACE-FUELS),  
Federal University of Technology Owerri, PMB 1526, Owerri, Nigeria*

<sup>2</sup>*Institute of Metal Research, Chinese Academy of Sciences, 62 Wencui Road, Shenyang 110016, China*

<sup>3</sup>*Northeastern University, No. 3-11 Wenhua Road, Shenyang 110819, China*

We investigated the corrosion inhibition mechanism of selected organic compounds on microstructurally different Fe and Al, with a view to deciphering the sensitivity of the interfacial processes to modifications in metal surface microstructure. Through a combination of electrochemical measurements, first principle density functional studies and an innovative mode of atomic force microscopy, the performance and structure of the adsorbed inhibitor films on both surfaces is visualized. Our findings show that metal surface modification (roughening) via nanocrystallization did not consistently improve adherence of every kind of corrosion inhibitor, rather the observed effect depended *ab initio* on the actual mechanism of the metal-inhibitor interactions on the polycrystalline metal surface. We also observed that inhibitor species become involved in the oxide film processes and actually stabilize the corrosion product film on the Al surface, with a compact highly ordered array of inhibitor molecules on the Al surfaces. The inhibitor film on the Al thin film however was more precisely ordered, with much smaller particles, suggesting some sort of microstructure-induced alignment of inhibitor species. These outcomes have significant implications for sandblasting pretreatments prior to anticorrosion coating applications.

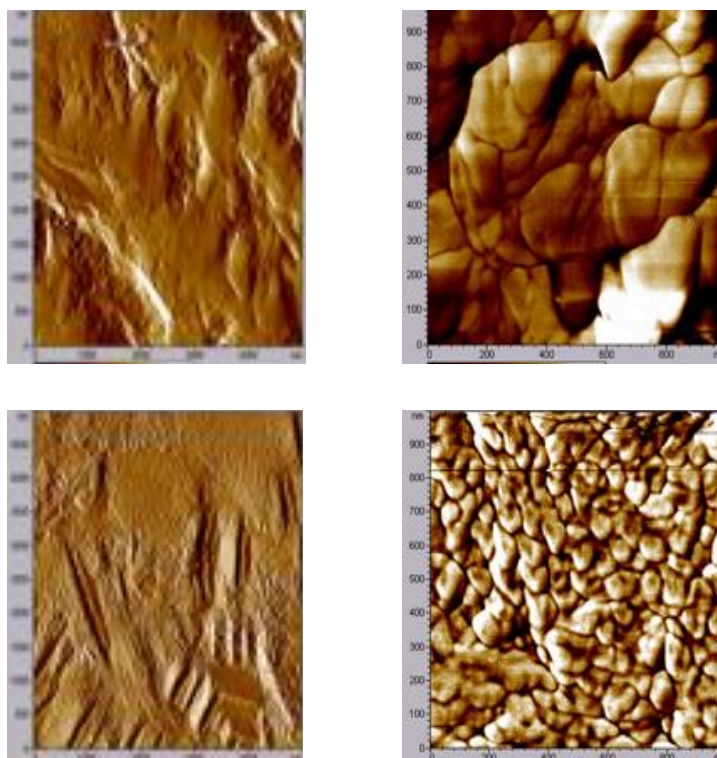

*Pristine polycrystalline (top) and microcrystalline (bottom) Al and with adsorbed inhibitor (RHS): The particles/grains of the additive are very closely packed with much smaller grains on microcrystalline Al*

### References

1. Maduabuchi A. Chidiebere, Emeka E. Oguzie, Li Liu, Ying Li, Akram N. Alshwabkeh, Fuhui Wang (2015) *RSC Advances*, 5 (2015) 93907–93916.
2. E.E. Oguzie, Y. Li, S.G. Wang, F.H. Wang, *RSC Advances*, 1 (2011) 866 – 873.
3. E.E. Oguzie, S.G. Wang, Y. Li, and F.H. Wang, *Journal of Physical Chemistry C*, 113, (2009) 8420 – 8429.
4. E.E. Oguzie, Y. Li, F.H. Wang, *Electrochimica Acta*, 52 (2007) 6988 – 6996.

# **Organic Electrochemistry and Bioelectrochemistry**

## Electrochemical investigation of fluorinated derivatives of 1,3-diphenylisobenzofuran, chromophores for singlet fission

Ludmila Šimková, Jiří Ludvík

Department of Molecular Electrochemistry and Catalysis, J. Heyrovský Institute of Physical Chemistry of the ASCR, v. v. i., Dolejškova 3, 182 23 Prague 8, Czech Republic

[ludmila.simkova@jh-inst.cas.cz](mailto:ludmila.simkova@jh-inst.cas.cz)

1,3-Diphenylisobenzofuran (DPIBF) is a known and commercially available compound which has been considered as a model chromophore for singlet fission.<sup>1</sup> Singlet fission is a photophysical process in which an organic chromophore in excited singlet state shares its excitation energy with a neighbouring ground-state chromophore and both are converted into two triplet states.<sup>1,2</sup> Singlet fission is possible to describe as an exchange of electrons between two molecules which does not require change of spin of any from the molecules. The redox properties of molecules for singlet fission are critical for their use in solar cells. From that reason electrochemical studies of various DPIBF derivatives are very important.<sup>3</sup> Our study is focused on a series of fluorinated derivatives of DPIBF where the influence of number and position of fluorine atoms in the molecule on the redox potentials and mechanism is followed. For electrochemical characterization of these molecules classical electrochemical techniques, and *in situ* UV-vis and EPR spectroscopy were used.

The oxidation as well as reduction patterns of all fluorinated derivatives are mostly analogous to non fluorinated DPIBF. From our results it is evident that the contribution of each fluorine atom is additive. In oxidation process fluorine atom in *p*-position has no big influence on potential values, moves the oxidation potential about 10 mV to higher positive values. On the other hand fluorine atom in *m*-position, due to its strong inductive effect, moved oxidation potential about 50–60 mV to high positive values. Next effect happens in the case of presence two fluorine atoms in *o*-position. The steric influence (twisting the phenyl ring out of the plane) causes lower electronic communication between individual parts of the molecule and thus different electrochemical and UV-vis response.

The reduction mechanism of all DPIBF derivatives is apparently of the EEC type. They are reduced in three or four reduction steps up to -2.9 V vs SCE. Only first two steps are discussed. More detailed study of the reduction mechanism would be necessary for interpretation of other reduction steps. The first reduction step is a one-electron reversible process. This step is connected with change of absorption at the range 1000 – 450 nm. Upon the course of the first reduction step the formation of anion radical was proved and the corresponding change on UV-vis spectra was observed. The fluorine atom in *o*- or *p*-position has no big influence on potential values. It is remarkable that the expected steric interaction of phenyl rings with fluorine atoms in *o*-position has no influence on reduction potentials in comparison with oxidation pattern. On the other hand the contribution of fluorine atom in *m*-position is high and causes a shift of reduction potential by about 70–85 mV to less negative values.

DPIBFs with 5 and 10 fluorine atoms differ substantially from the rest of the series of fluorinated DPIBFs. Their electrochemical reduction proceeds in two two-electron steps pointing to the change of mechanism. This problem is under study.

### References

1. M. B. Smith, J. Michl. *J. Chem. Rev.* **110** (2010) 6891.
2. M. B. Smith, J. Michl. *Annu. Rev. Phys. Chem.* **64** (2013) 361.
3. A. Akdag, A. Wahab, P. Beran, L. Rulíšek, P. I. Dron, J. Ludvík, J. Michl. *J. Organic Chemistry* **80** (2015) 8.

## Spectroelectrochemical studies of perfluoroalkylated derivatives of PAHs

Peter Machata<sup>1</sup>, Alexey Popov<sup>1</sup>, Tyler T. Clikeman<sup>2</sup>, Eric V. Bukovsky<sup>2</sup>, Steven H. Strauss<sup>2</sup>, Olga V. Boltalina<sup>2</sup>

<sup>1</sup> Leibniz Institute for Solid State and Materials Research, Helmholtzstraße 20, 01069 Dresden, Germany,

<sup>2</sup>Department of Chemistry, Colorado State University, 80523 Fort Collins, Colorado, USA

[p.machata@ifw-dresden.de](mailto:p.machata@ifw-dresden.de)

Since the early steps of its development, the field of molecular organic semiconductors has a pronounced imbalance toward p-type materials, despite many efforts dedicated to development of n-type organic semiconductors which might be comparable in stability and device performance with their p-type counterparts<sup>1-3</sup>. As a good candidate for potential application as n-type organic semiconductors can serve substituted polycyclic aromatic hydrocarbons (PAHs) presented in this work.<sup>4</sup>

Functionalization with electron-withdrawing groups, such as fluorine or perfluoroalkyl can have profound tuning effects upon the electronic and optical properties of organic compounds. It is one of the common methods to increase the electron affinity and improve the n-type properties of organic semiconductors<sup>1,5-8</sup>. Electrochemistry is a common tool to characterize the electron-accepting properties of molecular organic materials. Elucidation of the redox center of electrochemical process including mechanism of complex redox reactions often requires the use of complementary spectroscopic techniques. In this work, EPR-UV/Vis/NIR spectroelectrochemical studies of perfluoroalkylated PAHs were performed to get insight to the charge-transfer mechanism depending on chemical structure.

### References

1. J. E. Anthony, A. Facchetti, M. Heeney, S. R. Marder and X. Zhan, *Adv. Mater.* **22** (2010), 3876–3892.
2. C. Wang, H. Dong, W. Hu, Y. Liu and D. Zhu, *Chem. Rev.* **112** (2012), 2208–2267.
3. M. Mas-Torrent and C. Rovira, *Chem. Soc. Rev.*, **37** (2008), 827–838.
4. T. T. Clikeman, E. V. Bukovsky, X. B. Wang, Y. S. Chen, G. Rumbles, S. H. Strauss and O. V. Boltalina, *Eur. J. Org. Chem.*, **30** (2015), 6641-6654.
5. M.L. Tang, Z. Bao, *Chem. Mat.* **23** (2011), 446-455.
6. F. Baburdi, G.M. Farinola, F. Naso, R. Ragni, *Chem. Commun.* (2007) 1003-1022.
7. H. Sun, A. Putta, M. Billion, *J. Phys. Chem. A* **116** (2012) 8015-8022.
8. M.-H. Yoon, A. Facchetti, C.E. Stern, T.J. Marks, *J. Am. Chem. Soc.* **128** (2006) 5792-5801.

## Effect of tripodal anchoring groups (*meta* versus *para* position) on the charge transport in single oligophenylene molecular wires

Magdaléna Hromadová<sup>1</sup>, Viliam Kolivoška<sup>1</sup>, Jakub Šebera<sup>1</sup>, Táňa Sebechlebská<sup>1,2</sup>, Jindřich Gasior<sup>1</sup>, Štěpánka Nováková Lachmanová<sup>1</sup>, Gábor Mészáros<sup>3</sup>, Marcin Lindner<sup>4</sup>, Marcel Mayor<sup>4</sup>, Michal Valášek<sup>4</sup>

<sup>1</sup>J. Heyrovský Institute of Physical Chemistry of the Czech Academy of Sciences, Dolejškova 3, 182 23 Prague, Czech Republic

<sup>2</sup>Department of Physical and Theoretical Chemistry, Faculty of Natural Sciences, Comenius University in Bratislava, Mlynská dolina, Ilkovičova 6, 842 15 Bratislava, Slovak Republic

<sup>3</sup>Research Centre for Natural Sciences, HAS, Magyar Tudósok krt. 2, H-1117, Budapest, Hungary

<sup>4</sup>Karlsruhe Institute of Technology, Institute of Nanotechnology, P. O. Box 3640, 76021 Karlsruhe, Germany  
[magdalena.hromadova@jh-inst.cas.cz](mailto:magdalena.hromadova@jh-inst.cas.cz)

Advancement of molecular electronics relies on the enhancement of the stability and charge transport properties of molecules that could serve as individual molecular wires in the molecule-based electrical circuits. This work presents two types of molecules based on tetraphenylmethane tripodal anchors that are connected to the oligophenylene molecular wire. These differ in the *meta* and *para* position of thiolate

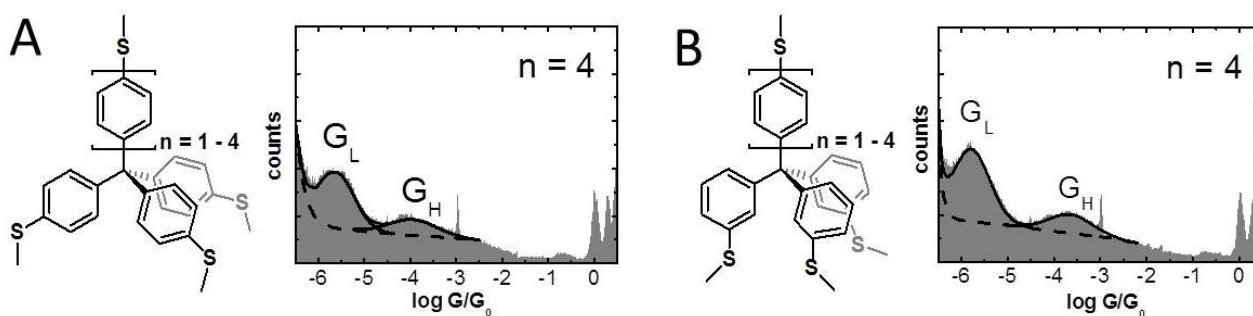

Chemical structure of *para* (A) and *meta* (B) substituted tripodal molecules and corresponding single molecule 1D conductance histograms obtained by scanning tunnelling microscopy break junction method.

anchoring groups of the tripod. For the longest oligophenylene wire with  $n = 4$ , the most probable molecular junction geometry is the following: three thiolate bonds of the tripod are anchored to one electrode and a single thiolate of the wire to another one, which brings about the desired conductance through the oligophenylene wire. Junction formation probability for *meta* functionalization is 68 % and for *para* 55 %, respectively. Single molecule conductance  $G$  for both molecules shows two peaks, where  $G_H$  represents the conductance through a tripodal platform only, whereas  $G_L$  that along the molecule through the tripod and molecular wire. Single molecule conductance for the longest studied *meta* functionalized molecule is  $\log G_H/G_0$  (*meta*) =  $-3.7 \pm 0.6$  and  $\log G_L/G_0$  (*meta*) =  $-5.8 \pm 0.5$ , whereas that for the longest studied *para* functionalized molecule is  $\log G_H/G_0$  (*para*) =  $-3.9 \pm 0.6$  and  $\log G_L/G_0$  (*para*) =  $-5.6 \pm 0.5$ . These results will be discussed in terms of the junction configuration, stabilization and suitability for the future molecular circuit design.<sup>1-3</sup>

Financial support by the Czech Science Foundation (18-04682S) and the Czech Academy of Sciences (RVO: 61388955) is gratefully acknowledged.

### References

1. J. Šebera, V. Kolivoška, M. Valášek, J. Gasior, R. Sokolová, G. Mészáros, W. Hong, M. Mayor, M. Hromadová, *J. Phys. Chem. C* **121** (2017) 12885.
2. M. Lindner, M. Valášek, J. Homberg, K. Edlmann, L. Gerhard, W. Wulfhekel, O. Fuhr, T. Wächter, M. Zharnikov, V. Kolivoška, L. Pospíšil, G. Mészáros, M. Hromadová, M. Mayor, *Chem. Eur. J.* **22** (2016) 13218.
3. T. Sebechlebská, J. Šebera, V. Kolivoška, M. Lindner, J. Gasior, G. Mészáros, M. Valášek, M. Mayor, M. Hromadová, *Electrochim. Acta* **258** (2017) 1191–1200.

## Electrochemical properties of substituted thioxothiazolidin-azulene

Veronica Anăstasoae<sup>1</sup>, Laura Enache<sup>1</sup>, Mihaela Cristea<sup>2</sup>, Raluca Isopescu<sup>1</sup>, Gabriela Stanciu<sup>3</sup>,  
Eleonora-Mihaela Ungureanu<sup>1</sup>

<sup>1</sup>University "Politehnica" of Bucharest, Faculty of Applied Chemistry and Materials Science,  
 Gheorghe Polizu 1-7, 011061 Bucharest, Romania <sup>1</sup>

<sup>2</sup>Institute of Organic Chemistry "C. D. Nenitzescu" of Romanian Academy,  
 Spl. Independentei 202 B, P.O. Box 108, 060023 Bucharest 35, Romania

<sup>3</sup>Department of Chemistry and Chemical Engineering, Ovidius University, Constantza,  
 124 Mamaia Blvd, 900527, Romania

Several derivatives of thioxothiazolidin-azulene have been studied as ligands for heavy metal ions recognition. The electrochemical experiments were carried out by cyclic voltammetry, differential pulse voltammetry and rotating disk electrode voltammetry. The complexing properties of the ligands and their modified electrodes have been investigated towards heavy metals by anodic stripping technique.

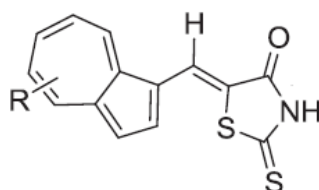

Scheme 1. Structure of investigated compounds R = 3,4,6,8-H, 4,6,8-Me3, 3,8-Me2-5-iPr

The electrochemical characterization of several derivatives of thioxothiazolidine-azulene have been studied using cyclic voltammetry, differential pulse voltammetry and by rotating disk electrode. The modified electrodes were obtained by successive cyclic or by controlled potential electrolysis at different potential or charges. The response of the modified electrode for heavy metals recognition at different concentration was evaluated. In order to detect lower concentrations of analytes the electrode preparation before detection has been optimized.

*Acknowledgements:* The authors are grateful for the financial support from: PCCDI programe, INTELMAT project complement 5 and UEFISCDI project contract no. 236/2014.

### References

1. L., Birzan, M. Cristea, C. Draghici, V. Tecuceanu, M. Maganu, A. Hanganu, G.-L. Arnold, E.-M. Ungureanu, A.C. Razus, *Tetrahedron* 72, 2016, 2316–2326.
2. G.-O. Buica, E.-M. Ungureanu, A. C Razus, L. Birzan, M.-R. Bujduveanu, *Elchim. Acta* 56, 2011, 5028-5036.
3. G.-O. Buica, I.-G. Lazar, L. Birzan, C. Lete, M. Prodana, M. Enachescu, V. Tecuceanu, A.B. Stoian, E.-M. Ungureanu, *Elchim. Acta* 263 (2018) 382-390.

## On the reaction of polyphenols with copper dication

Romana Sokolová<sup>1</sup>, Veronika Majarová<sup>1</sup>, Michaela Obluková<sup>1</sup>, Jan Vacek<sup>2</sup>, Vladimír Křen<sup>3</sup>

<sup>1</sup>J. Heyrovský Institute of Physical Chemistry of the Czech Academy of Sciences, Dolejškova 3, 18223 Prague, Czech Republic

<sup>2</sup>Department of Medical Chemistry and Biochemistry, Faculty of Medicine and Dentistry, Palacký University, Hněvotínská 3, 77515 Olomouc, Czech Republic

<sup>3</sup>Institute of Microbiology of the Czech Academy of Sciences, Center of Biocatalysis and Biotransformation, Vídeňská 1083, 14220 Prague, Czech Republic

[sokolova@jh-inst.cas.cz](mailto:sokolova@jh-inst.cas.cz)

The chemical reaction of polyphenol silybin with copper dication was investigated by means of spectrophotometry, electrochemistry and UV-Vis spectroelectrochemistry.

Silybin belongs to a group of flavonolignans produced in the plant *Silybum marianum* (L.) Gaertner [1]. The antioxidant and hepatoprotective properties of flavonolignans were reported during the last two decades. Electrochemical oxidation of silybin acts on hydroxy group at the ring E and it leads to the formation of hydroxylated product in the presence of water [2]. The reaction of flavonolignans with metallic cations especially the ability of the copper and iron complexes formation has a significant importance for bioactivity and pro-oxidation action. In addition, transition metals could be used for selective oxidation and development of synthetic protocols and biosensing methods for flavonolignans and other polyphenols [3]. The changes of the intensity of absorption bands during reaction with different concentrations of copper showed the presence of two competitive processes *i.e.* silybin oxidation by copper dication and Cu-silybin complexation. These two parallel reactions were possible to distinguish by analysing of absorption spectra obtained during electrochemical oxidation of silybin and methoxy derivative of silybin as well. The ratio between copper and ligand was determined by Job's method of continual variations [4].

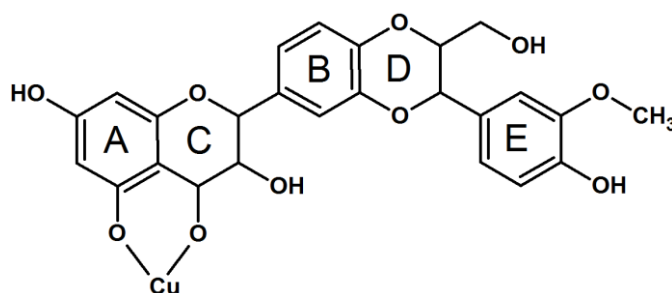

Figure 1: The putative structure of silybin complex with Cu.

**Acknowledgement:** This work is supported by the Czech Science Foundation (GAČR 19-03160S).

### References

1. D. Biedermann, E. Vavrikova, L. Cvak, V. Kren: *Nat. Prod. Rep.* **31** (2014) 1138.
2. R. Sokolova, J. Tarabek, B. Papouskova, J. Kocabova, J. Fiedler, J. Vacek, P. Marhol, E. Vavříková, V. Křen: *Electrochim. Acta* **205** (2016) 118.
3. V. Tvrdy, M. C. Catapano, T. Rawlik, J. Karlickova, D. Biedermann, V. Kren, P. Mladenka, K. Valentova:
4. *J. Inorg. Biochem.* **189** (2018) 115.
5. J. S. Renny, L. L. Tomasevich, E. H. Tallmadge, D. B. Collum: *Angew. Chem. Int. Ed.* **52** (2013) 11998.

## Electrochemical behaviour of toluylene blue

D. Vishenkova<sup>1</sup>, E. Korotkova<sup>1</sup>, J. Barek<sup>2</sup>

<sup>1</sup> National Research Tomsk Polytechnic University, School of Natural Resources, Department of Chemical Engineering, Lenin avenue, 30, Tomsk, 634050, Russia

<sup>2</sup> Charles University, Faculty of Science, Department of Analytical Chemistry, UNESCO Laboratory of Environmental Electrochemistry, Hlavova 8/2030, CZ 128 43 Prague 2, Czech Republic  
[vishenkova\\_darya@mail.ru](mailto:vishenkova_darya@mail.ru)

The cationic basic dye of the indamine series molecule, N-(4-((2,4-diamino-5-methylphenyl)imino)cyclohexa-2,5-dien-1-ylidene)-N-methylmethanaminium chloride, popularly called Toluylene Blue (TB), has long been used as an indicator in redox titration (figure 1) [1].

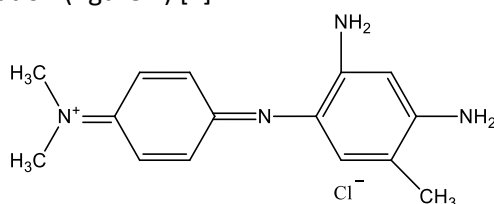

Figure 1. Structural formula of TB

The study of the electrochemical properties of the TB by means of voltammetry has not previously been conducted, and therefore, the investigation of its electrochemical behavior is of interest from a scientific point of view. Initially, the TB electrochemical properties were carried out by cyclic voltammetry with a constant current potential scan on different electrode materials (mercury film electrode, glassy carbon electrode, modified carbon ink electrode) in background electrolytes with different pH values. The form of the obtained voltammograms led to conclude that the redox process of the TB is multi-stage. Based on the greater stability and linearity of the cathodic and anodic peaks for studying TB electrochemical properties was selected the modified carbon ink electrode (ME). Figure 2 shows the cyclic voltammogram of TB on ME in a Britton-Robinson buffer solution with pH 2.

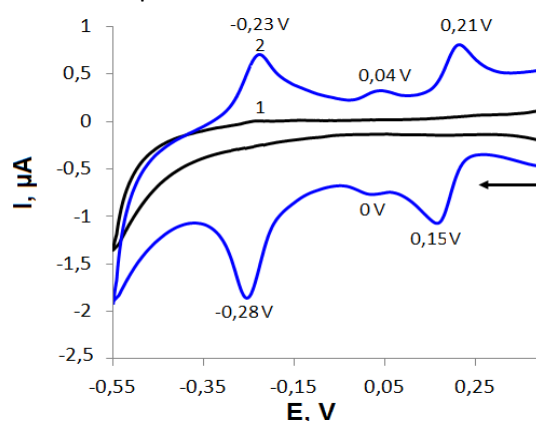

Figure 2. Cyclic voltammogram of TB on ME: 1 - background curve; 2 - TB 5 mg/dm<sup>3</sup>. W = 40 mV/s, pH=2

In order to establish the mechanism of a redox processes and adsorption of the dye, the effect of pH, potential scanning rate and temperature on the TB electrochemical signal were carried out.

In this research, the investigation of electrochemical properties of TB was performed for the purpose of its further application as a sensor for the indirect determination of not electrochemically active compounds such as heparin and hyaluronic acid by means of voltammetry.

*Acknowledgement:* This work was financially supported by the Ministry of Education and Science of the Russian Federation (the project "Science" № 4.5752.2017)

### References

1. Curr, E. Synthetic dyes in Biology, Medicine and Chemistry. Academic Press. (1971) 814 p.

# **Electroanalytical Chemistry and Sensors**

## Insights into copper film electrodes for voltammetric determination of trace toxic elements

Vasko Jovanovski, Nana Ivana Hrastnik, Urša Klun

Analytical Chemistry Department, National Institute of Chemistry, Hajdrihova 19, SI-1000 Ljubljana  
[vasko.jovanovski@ki.si](mailto:vasko.jovanovski@ki.si)

Metal-film electrodes have gained wide interest in trace analysis due to their good performance, fast and reliable response and simple and fast fabrication and operation [1]. Among the most widely employed electrochemical techniques stripping voltammetry is usually employed when the analyte of interest can be electrochemically accumulated on the surface of the modified working electrode.

Since 2000 bismuth [2] and later antimony [3] film electrodes revealed pertinent characteristics for trace toxic metal ion detection associated with performance similar to the traditional mercury based electrodes. These non-mercury electrodes offer low background and measurements in the presence of dissolved oxygen. Recently, copper film electrode (CuFE) was introduced in combination with anodic stripping voltammetry for simultaneous detection of trace mercury and lead [4]. The electrode exhibited performances similar to or even surpassing gold-based electrodes in terms of sensitivity.

In this presentation we will focus on the optimization of key parameters for electrode preparation and operation. Several interesting features of CuFE will be discussed, for example measurements of trace mercury in sea water [5].

We will show that this inexpensive environmentally friendly electrode has great potential for detection of trace levels of numerous toxic elements.

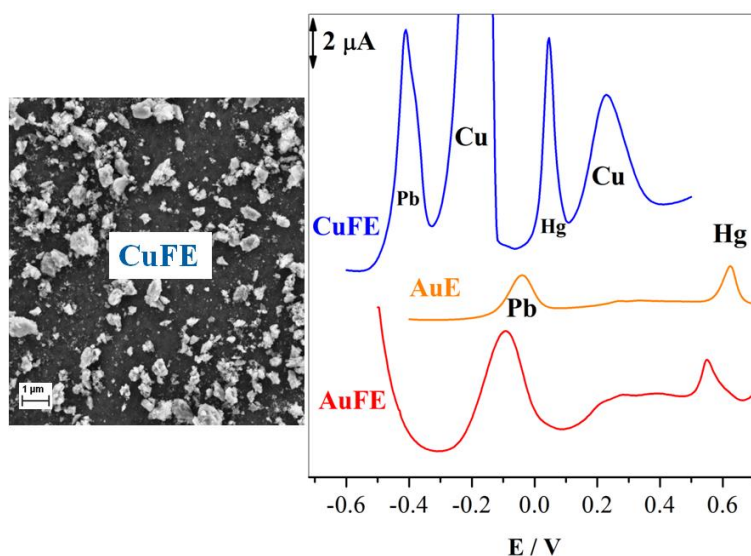

Figure showing morphology of electrodeposited CuFE and corresponding performance in comparison with gold disc (AuE) and gold film (AuFE) electrodes for measuring 40 µg L<sup>-1</sup> of both Pb(II) and Hg(II).

### References

1. J. Wang, *Analytical Electrochemistry*, Wiley-VCH, Hoboken, New Jersey, 2006.
2. J. Wang, J. Lu, S.B. Hocevar, P.A.M. Farias, B. Ogorevc, *Anal. Chem.* **72** (2000) 3218.  
<https://dx.doi.org/10.1021/ac000108x>
3. S.B. Hocevar, I. Švancara, B. Ogorevc, K. Vytřas, *Anal. Chem.* **79** (2007) 8639.  
<https://dx.doi.org/10.1021/ac070478m>
4. V. Jovanovski, N.I. Hrastnik, S.B. Hočevár, *Electrochem. Commun.* **57** (2015) 1.  
<http://dx.doi.org/10.1016/j.elecom.2015.04.018>
5. V. Jovanovski, N.I. Hrastnik, *Microchem. J.* in press. <https://doi.org/10.1016/j.microc.2019.02.027>

## Understanding the gold microwire electrode behavior for the detection of trace metals

Marija Marguš<sup>1,2</sup>, Pierre-Jean Superville<sup>1</sup>, Gabriel Billon<sup>1</sup>

<sup>1</sup> Université de Lille, LASIR, Cité Scientifique, 59655 Villeneuve d'Ascq, France

<sup>2</sup> Ruđer Bošković Institute, Division for Marine and Environmental Research, Bijenička 54,  
10000 Zagreb, Croatia

[mmargus@irb.hr](mailto:mmargus@irb.hr)

Electroanalytical methods are widely used for determination of various contaminants at environmentally relevant conditions. The cost-efficient technology and technical setup that gives possibility to perform *in situ* measurements are two of the main drivers in application of electrochemical measurements (EM). For successful application of the EM, the key point is to choose the optimal analytical setup that will provide a good sensitivity, selectivity and detection limits. One of the crucial steps is the choice of the appropriate working electrode that must provide optimal sensitivity and stability, as well as non-toxicity for environmental application. The alternative materials of liquid mercury are solid electrodes, which have been developed for *in situ* applications during these last ten years [1-3].

In this study, the targeted pollutants are trace metals (TM) and the solid electrode is a gold microwire ( $\mu\text{Au}$ ) for the following reasons [2]: (i) its chemical inertness and resistance to access simultaneous detections and speciation of several trace metals; (ii) its possibility to use vibration instead of stirring; (iii) its surface stability compared to classical Au macro-electrode, allowing long-term *in situ* monitoring.

Although the  $\mu\text{Au}$  has significantly improved the analysis of the trace metals to obtain reliable results, the appropriate choice of the experimental conditions and monitoring of the changes in the  $\mu\text{Au}$  induced by the repetitive use are crucial. The objective of the work is to understand the underlying mechanism and changes occurring during the application of the  $\mu\text{Au}$  in detection of TM in natural samples. For that purpose, two different kind of samples were considered: dredged sediments and river water.

The aged dredged sediment samples were analyzed in the field at a  $\mu\text{Au}$  with voltammetry to determine total TM concentrations in samples after acid digestion and filtration. In the samples, Pb and Cu were systematically detected at pH=2, and to detect Zn in the samples, the pH had to be adjusted at a value of 3. Applicability of the  $\mu\text{Au}$  for the speciation of TM in the Deule River (France) and electrode stability was tested with *in situ* long-term monitoring. The voltammetric measurements were carried out at the natural pH and in acidified samples. At the natural pH values, only Pb was detected, while after acidification (pH = 2) both Pb and Cu were measured. The changes in the  $\mu\text{Au}$  electrode surface were observed during the long-term application of the electrode and chemical activation/cleaning procedures will be discussed.

### References:

1. M. Li, D.W. Li, G. Xiy, Y.T. Long, *Curr. Opin. Electrochem.* **3** (2017) 137-147 (doi:10.1016/j.coelec.2017.08.016)
2. M. Briyani, R. Biyani, T. Tsuchihashi, Y. Takamura, H. Ushijima, Y. Takamura, H. Ushijima, E. Tamiya, M. Biyani, *Sensors* **45** (2017) 1-14 (doi: 10.3390/s17010045)
3. G.M.S. Alves, J.M.C.S. Magalhes, H.M.V.M.S. Soares, *Electroanalysis* **25** (2013) 493-502 (doi: 10.1002/elan.201200518)
4. P. Arhens, M. Zander, U. Hasse, H. Wulff, C. Jeyabharathi, A. Kruth, F. Sholz, *Chem. Electro. Chem.* **5** (2018) 943-957 (doi: 10.1002/celec.201700745)

Acknowledgements: The work was founded by InterReg project VALSE « Nouvelles ressources transfrontalières : vers une validation de scénarii de valorisation de sédiments et autres matériaux ».

5.

## Thin gold film electrode for voltammetric determination of Chromium (VI)

Nevila Broli, Majlinda Vasjari

Faculty of natural Science, Department of Chemistry, University of Tirana

Faculty of natural Science, Department of Chemistry, University of Tirana

[nevilabroli@yahoo.com](mailto:nevilabroli@yahoo.com) [nevila.brroli@fshn.edu.al](mailto:nevila.brroli@fshn.edu.al)

A gold film modified glassy carbon electrode ( $Au_{film}/GCE$ ) was developed for the determination of chromium (VI) in water sample. GCE was immersed into  $HAuCl_4$  solution ( $10^{-3}M$ ) and electrodeposition of thin gold layer was conducted at  $-0.4 V$  (vs  $Ag/AgCl$ ) for 10 min. The strong affinity between Au and Cr species resulted with increasing reduction current of Cr (VI), compared with the bare glassy carbon electrode. The differential pulse stripping voltammetry was used for electrochemical detection of Chromium (VI). The concentration of indifferent electrolyte, the electrodepositing time, pre-concentration potential and the stripping interval were optimized. The analytical performance of the electrode has been evaluated regarding to sensitivity, linear behavior, and detection limit. The calibration graph using accumulation time of 120 s was linear from 9.9 to  $117 \mu gL^{-1}$  with a sensitivity  $1.3 \times 10^{-2} \mu A/\mu gL^{-1}$ . Under optimum experimental conditions, a good correlation coefficient  $R=0.9971$  and a low detection limit  $5.5 \mu g/L$  Cr (VI) was obtained. The signal was reproducible with a relative standard deviation  $\pm 4.5 \%$ . The modified sensor was used for the determination of Cr (VI) in sewage water samples.

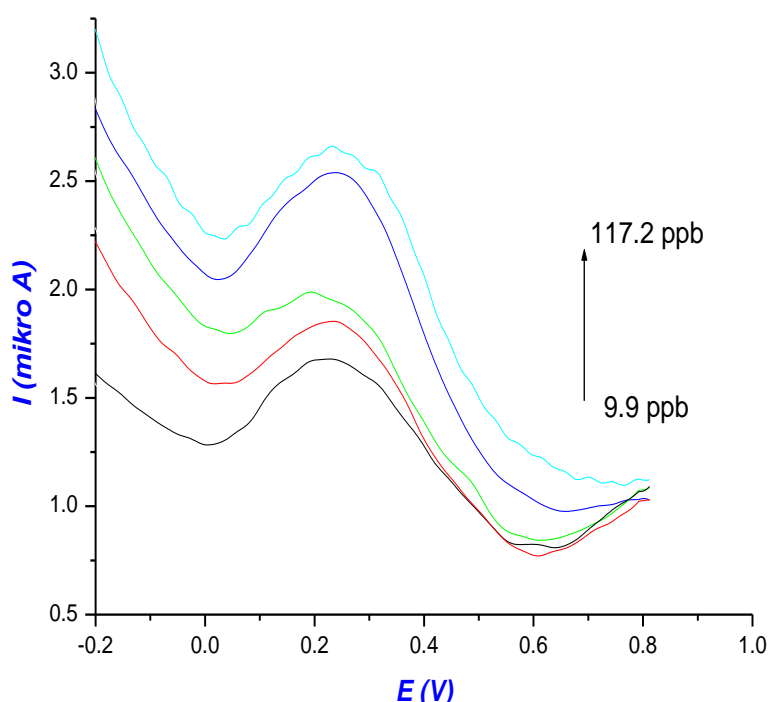

Voltammograms registered with  $Au_{nano}/GCE$  electrode in  $HCl$  0.1 M,  $t_{dep}=120$  s, poteciencial from 1.0 to -0.2 V in different concentration of  $Cr^{6+}$

### References

1. G. Liu, J. Y-Y. Lin, Y. H. Wu and Y. Lin. *Environmental Science & Technology* 41.(2007) pp 8129-8134. <https://pubs.acs.org/doi/10.1021/es071726z>
2. L.E. Korshoj, A.J. Zajtouna and Y.L. Rebecca. *Analytical Chemistry*. 87(5), ( 2015), ppt 2560-2564. <https://pubs.acs.org/doi/abs/10.1021/acs.analchem.5b00197>
3. PujaBiswas<sup>ab</sup>Abhinav KumarKarn<sup>aP</sup>.Balasubramanian<sup>b</sup>Paresh G.Kale<sup>a</sup> *Biosensors and Bioelectronics*.Volume 94, 15 (2017), Pages 589-604. <https://doi.org/10.1016/j.bios.2017.03.043>

## **Novel methodology for investigating electrochemical gas evolution reactions: a case study of oxygen evolution reaction using floating electrode for effective oxygen bubble removal**

Primož Jovanovič, Kevin Stojanovski<sup>1</sup>, Marjan Bele<sup>2</sup>, Luka Suhadolnik<sup>3</sup>, Goran Dražič<sup>2</sup>, Gorazd Koderman Podboršek<sup>2</sup>, Miran Gaberšček<sup>2,4</sup>, Nejc Hodnik<sup>1</sup>

*Department of Catalysis and Chemical Reaction Engineering, National Institute of Chemistry, Hajdrihova 19, SI-1000 Ljubljana, Slovenia*

<sup>1</sup> *Department of Catalysis and Chemical Reaction Engineering, National Institute of Chemistry, Hajdrihova 19, SI-1000 Ljubljana, Slovenia*

<sup>2</sup> *Department of Materials Chemistry, National Institute of Chemistry, Hajdrihova 19, SI-1000 Ljubljana, Slovenia*

<sup>3</sup> *Department for Nanostructured Materials, Jožef Stefan Institute, Jamova 39, SI-1000 Ljubljana, Slovenia*

<sup>4</sup> *Faculty of Chemistry and Chemical Technology, University of Ljubljana, Večna pot 113, SI-1000 Ljubljana, Slovenia*

[primoz.jovanovic@ki.si](mailto:primoz.jovanovic@ki.si)

The future significance of energy conversion has stimulated intense investigation of various electrocatalytic materials. Hence electrocatalysts have become a subject of electrochemical characterization on a daily basis. In certain cases of interest, when measuring electrochemical reactions beyond the onset potentials, however, appropriateness of existing electroanalytical methods may be questioned and alternative approaches need to be developed. The present study highlights some shortcomings in the electrochemical investigation of gas evolving reactions. Oxygen evolution reaction (OER) is selected as a case example with a specific focus on the electrochemical stability of a nanoparticulate iridium catalyst. When conventional electrochemical methods, such as thin film rotating disc electrodes are employed to study the materials stability, the intrinsic degradation is masked by oxygen bubbles, which are inherently being formed during the reaction, especially when high current densities are used. In this paper, we present a solution for this issue, the so-called floating electrode arrangement. Its elegant usage enables fast and reliable electrochemical characterization of oxygen evolution electrocatalysts.

## Development of hydrogen peroxide gas sensor for security applications

J. Isailović<sup>1</sup>, V. Jovanovski<sup>1</sup>, P. Jovanović<sup>2</sup>

<sup>1</sup> Department of Analytical Chemistry, National Institute of Chemistry, Hajdrihova 19, SI-1000 Ljubljana, Slovenia

<sup>2</sup> Department of Catalysis and Chemical Reaction Engineering, National Institute of Chemistry, Hajdrihova 19, SI-1000 Ljubljana, Slovenia  
[jelena.isailovic@ki.si](mailto:jelena.isailovic@ki.si)

Concerns related to global security have given rise to increased research in the field of explosive detection, aimed at developing analytical methods for fast, sensitive, and simple determination of explosives in trace amounts [1]. Particular attention has been given to the peroxy-based explosives due to their increasing usage [2], the issue being that the standard chemical identification techniques are not suitable for peroxy explosives. Hydrogen peroxide, which is both precursor and degradation product of peroxy explosives, is a redox active compound prone to both oxidation and reduction. This implies that electrochemical techniques offer themselves as a prime choice in detection of peroxide-based explosives [3].

In designing gas electrochemical sensors the electrode surface has to be modified to achieve high electrocatalytic properties. There are several possible ways how to achieve this, for examples modification of the electrode surface [4]. Furthermore, besides electrocatalytic properties of the surface modified electrode, the overall performances of H<sub>2</sub>O<sub>2</sub> electrochemical gas sensors depends on the electrochemical technique applied, *i.e.* the excitation protocol in the course of the operation of the sensor. In this context, better outcomes can be achieved with advanced voltammetric techniques such as fast scan cyclic voltammetry and square-wave voltammetry [6].

Our current investigation has been focusing on the development of semi-solid electrolytes comprising several functions: **i)** accumulation of the analyte from the gaseous phase thus considerably improving sensitivity, **ii)** derivatization of the gas analyte facilitating more accessible electrochemical detection or even chemical derivatization of electrochemically inactive compounds into electrochemically active ones and finally, **iii)** semi-solid ionic electrolyte offering rapid diffusion of the analyte to the electrode surface. Recent results in along these lines for electrochemical detection of gaseous H<sub>2</sub>O<sub>2</sub> will be discussed.

### References

1. J.S. Caygill, F. Davis, S.P.J. Higson, Current trends in explosive detection techniques, *Talanta* **88** (2012) 14-29 (<https://doi.org/10.1016/j.talanta.2011.11.043>).
2. R.M. Burks, D.S. Hage, Current trends in the detection of peroxide-based explosives, *Analytical and Bioanalytical Chemistry* **395** (2009) 301-313 (<http://dx.doi.org/10.1007/s00216-010-3480-7>).
3. J. Wang, Electrochemical Sensing of Explosives, *Electroanalysis* **19** (2007) 415-423 (<https://doi.org/10.1016/B978-044452204-7/50023-7>).
4. R. Pauliukaite, S.B. Hočevar, E.A. Hutton, B. Ogorevc, Novel electrochemical microsensor for hydrogen peroxide based on iron-ruthenium hexacyanoferrate modified carbon fiber electrode, *Electroanalysis* **20** (2008) 47-53 (<https://doi.org/10.1002/elan.200704047>).
5. D. Lu, A. Cagan, R.A.A. Munoz, T. Tangkuaram, J. Wang, Highly sensitive electrochemical detection of trace liquid peroxide explosives at a Prussian-blue 'artificial-peroxidase' modified electrode, *Analyst* **131** (2006) 1279-1281 (<https://pubs.rsc.org/en/Content/ArticleLanding/2006/AN/b613092e#ldivAbstract>).
6. C. Batchelor-Mcauley, E. Kätelhön, E.O. Barnes, R.G. Compton, E. Laborda, A. Molina, Recent Advances in Voltammetry, *ChemistryOpen* **4** (2015) 224-260 (<https://doi.org/10.1002/open.201500042>).

## Development of ISE-Cl<sup>-</sup> using modified polymeric membrane

Majlinda Vasjari, Nevila Broli, Sadik Cenolli

University of Tirana, Faculty of Natural Sciences, Department of Chemistry, "Bulevardi Zogi I", Nr 2. Tirana  
[majlinda.vasjari@fshn.edu.al](mailto:majlinda.vasjari@fshn.edu.al)

Home made ion selective electrodes based on modified polymeric membrane and a graphite contact line are developed onto acetate paper platforme. The simplicity of preparation, low cost and easy modification way of polymeric membrane are considered as important advantages. Analytical performance regarding sensitivity, good repeatability and good linearity of response is studied. Modification procedure of the polymeric membrane and the ratio between membrane components are optimized. The potentiometric response of home-made ISE resulted according to Nernstian equation from  $10^{-4}$ M to  $10^{-1}$ M of Chloride ions with a sensitivity up to  $S = -57.82$  mV/decade and  $R^2 = 0.9989$ . The interference of sulphate ion is studied and the selectivity coefficients are determined. The selectivity relating Cl<sup>-</sup> ions resulted over 30 times higher compared to sulfate ions.

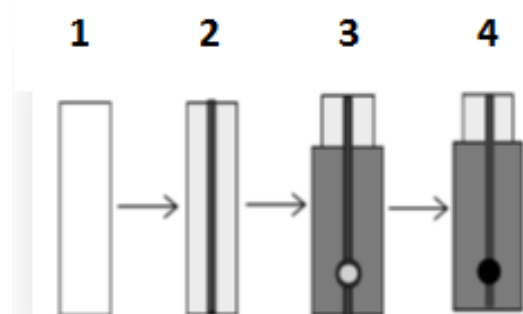

Fig.1. Four steps for preparation of home made ISE:  
 1)acetate paper platforme; 2)graphite contact line;  
 3) coverage with a non-conductive paper;  
 4) adhesion of polymeric membranes

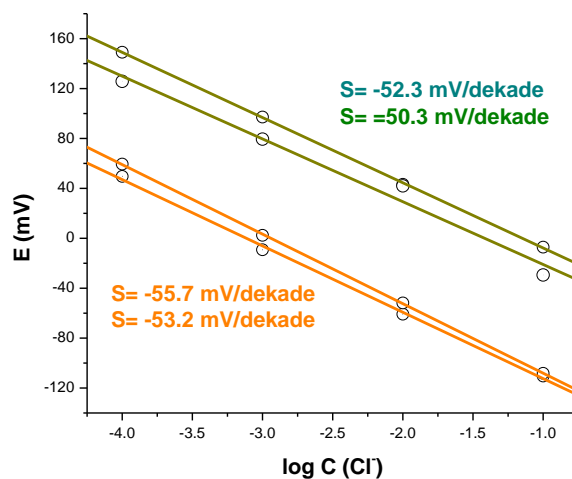

Fig 2. Calibration plots obtained using different ISE-Cl<sup>-</sup>

### References

1. L Mendecki, T Fayose, K A. Stockmal, J Wei, S G-Focil, C M. McGraw, A Radu, *Anal. Chem.* 2015, 87, 7515–7518
2. Kawde A.-N., Baig N., Sajid M. *RSC Advances*.2016, 91325-91340
3. T. Fayose, L Mendeck, S Ullahb., A Radu, *Anal. Methods* 2017, 9, 1213–1220

# **General Topics and Physical Electrochemistry**

## Investigation of the vanadium redox system by dual voltammetry

Mária Ujvári, Soma Vesztergom, Szabolcs Gyulai-Gaál<sup>1</sup>, Gyöző G. Láng

Institute of Chemistry, Eötvös Loránd University, Budapest, H-1117 Budapest, Pázmány P. s. 1/A, Hungary

<sup>1</sup>Department of Oral Diagnostics, Faculty of Dentistry, Semmelweis University, Budapest, H-1088 Budapest, Szentkirályi u. 47, Hungary

[ujvari.maria@chem.elte.hu](mailto:ujvari.maria@chem.elte.hu)

Vanadium in its compounds exists in different oxidation states ranging from +2 to +5, so its electrochemistry is very rich and versatile. The vanadium salts have practical applications in power sources: the most marketed type of redox flow batteries is the vanadium containing one [1]. Despite their limited energy and power densities, the advantage of these batteries are that no cross-contamination occurs and they have unparalleled cycle lives. Vanadium also plays an important role in the steel & iron industry as a steel additive, and in dental implants as alloying element of titanium [2], therefore vanadium electrochemistry is also important for corrosion scientists. It is claimed that vanadium containing implants have better mechanical properties and smaller implant size compared to pure titanium ones.

Here we study the redox transformations of vanadium species by cyclic voltammetry and dual dynamic voltammetry using a rotating ring disk electrode system. In dual voltammetric measurements [3] both the ring and the disk are controlled potentiodynamically at the same time. During the slow polarization of the disk cyclic voltammograms are recorded on the ring at high scan rates. Plotting the ring current as the function of the ring and the disk potential results in a "3D electrochemical map" of the system.

The dependence of cyclic voltammograms (recorded at stationary and rotating disk electrodes) on pH is also very interesting. At low pH values only a few peaks can be observed on the voltammetric curves, nevertheless, at higher pH values the shapes of the voltammograms well reflect the multistep oxidation–reduction processes, *i.e.* the complexity of the system.

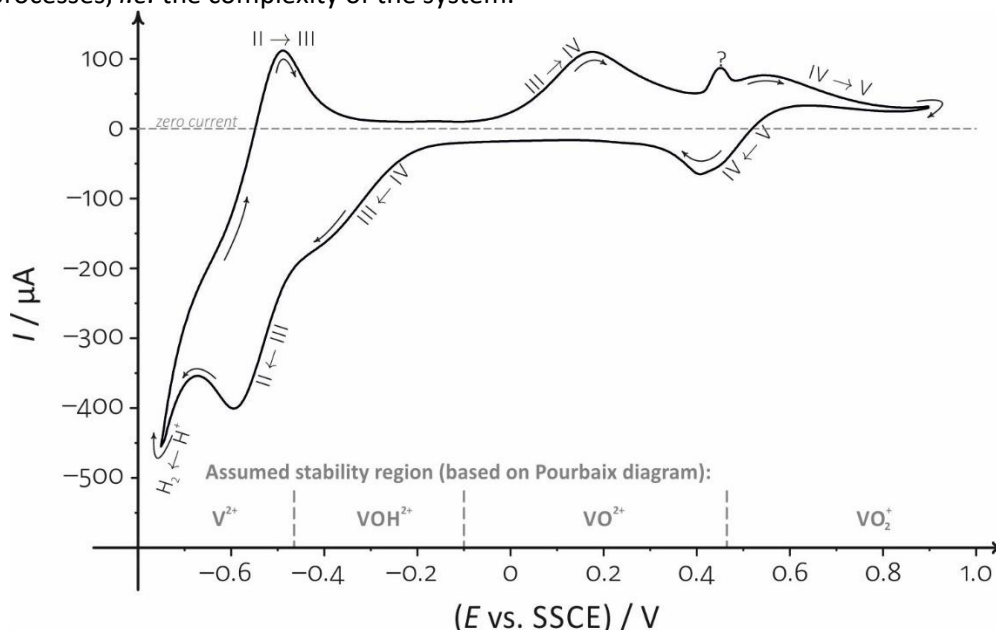

Cyclic voltammogram of  $VOSO_4$  in sulphuric acid/sodium sulphate solution (pH=2.3) on gold.  
Sweep rate 144 mV/s, rotation rate is 0 rpm.

### References

1. Á. Cunha, F. P. Brito, J. Martins, N. Rodrigues, *International Journal of Energy Research* **39**(7), (2015) 889–918 (<https://doi.org/10.1002/er.3260>)
2. N. Kovács, L. Sziráki, S. Vesztergom, G. G. Láng, *J. Electrochem. Sci. Eng.* **8**(2) (2018) 141-149 (<http://dx.doi.org/10.5599/jese.502>)
3. S. Vesztergom, N. Kovács, M. Ujvári, G. G. Láng, *Technisches Messen* **84**(10) (2017) 683–696 (<https://doi.org/10.1515/teme-2016-0083>)

## A model for hydrogen evolution on RDEs: Are the limiting current plateau lengths indicative of electrocatalytic activity?

Soma Vesztergom<sup>1</sup>, María de Jesús Gálvez-Vázquez<sup>2</sup>, Vitali Grozovski<sup>2</sup>, Noémi Kovács<sup>1,2</sup>, Peter Broekmann<sup>2</sup>

<sup>1</sup>Eötvös Loránd University of Budapest, Department of Physical Chemistry, H–1117 Budapest, Pázmány Péter sétány 1/A, Hungary

<sup>2</sup>University of Bern, Department of Chemistry and Biochemistry, CH–3012 Bern, Freiestrasse 3, Switzerland  
[vesztergom@chem.elte.hu](mailto:vesztergom@chem.elte.hu)

Polarization curves of the hydrogen evolution reaction (HER), recorded on rotating disk electrodes (RDEs) in mildly acidic solutions, usually show a “two step” behaviour. That is, two exponentially rising segments (the first commonly assigned to H<sup>+</sup>, the second to water reduction) are separated by a limiting current plateau. Here we devise an analytical model for the current density by relying on two assumptions: i.) that HER proceeds according to a single, quasi-reversible 2-electron reaction, H<sup>+</sup> + H<sub>2</sub>O + 2e<sup>-</sup> = H<sub>2</sub> + OH<sup>-</sup>, obeying the Erdey-Grúz–Volmer–Butler equation; and ii.) that the diffusion coefficients of H<sup>+</sup> and OH<sup>-</sup> ions are equal. Our model is able to reproduce the “two step” behaviour of polarization curves, and can also be used for the fitting of measured currents over a broad range of pH, rotation rate and electrode potential, on both Au and on Pt (see Figure 1).

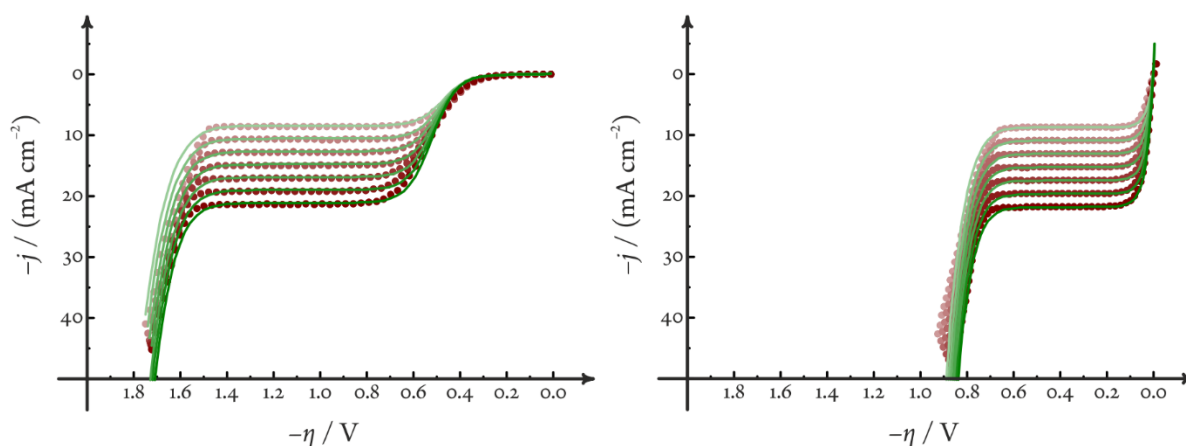

Figure 1. Sets of polarization curves recorded on a gold (left) and on a platinum (right) disk electrode, rotated at 400, 625, 900, 1225, 1600, 2025 and 2500 min<sup>-1</sup> (from top to bottom) of rotation rates in a pH = 2.35 solution of NaClO<sub>4</sub> + HClO<sub>4</sub>. Red dots are measured data; green curves are created by fitting the analytical model presented in the talk. Note that the limiting current plateau lengths differ for the two metals

Table 1. Values of the diffusion coefficient of H<sup>+</sup> ions (D), as well as the reaction rate coefficient k and the charge transfer coefficient α of hydrogen evolution, determined for Au and Pt on a pH interval of 2 < pH < 4 by fitting the developed model to measured data

Electrode	D / (10 <sup>-4</sup> cm <sup>2</sup> s <sup>-1</sup> )	lg(k / (m s <sup>-1</sup> ))	α
Au	1.027 ± 0.053	-5.10 ± 0.26	0.486 ± 0.067
Pt	1.069 ± 0.043	0.024 ± 0.050	0.643 ± 0.037

We are the first to show that the length of the limiting current plateaus measured on RDEs for HER are inversely related to the electrocatalytic activity of the electrode, and that at a given rotation rate, a linear relationship exists between the plateau length and the bulk solution pH. By analysing this relationship, we can estimate kinetic parameters (see Table 1), even in cases where it is commonly assumed that the transport performance of RDEs does not permit the measurement of well-defined kinetic currents.

## Ammonia synthesis under ambient conditions by electrochemical nitrogen reduction

Viktor Čolić<sup>1</sup>, Sungeun Yang<sup>1</sup>, Suzanne Z. Andersen<sup>1</sup>, Kasper Enemark-Rasmussen<sup>2</sup>, Peter C.K. Vesborg<sup>1</sup>, Ifan E.L. Stephens<sup>3</sup>, Jakob Kibsgaard<sup>1</sup>, Ib Chorkendorff<sup>1</sup>

<sup>1</sup>Section for Surface Physics and Catalysis, Department of Physics, Technical University of Denmark, Building 312, DK-2800 Kongens Lyngby, Denmark

<sup>2</sup>Organic and Inorganic Chemistry, Department of Chemistry, Technical University of Denmark, Building 207, DK-2800 Kongens Lyngby, Denmark

<sup>3</sup>Department of Materials, Imperial College London, Royal School of Mines, Exhibition Road SW7 2AZ, London, United Kingdom

[colic@fysik.dtu.dk](mailto:colic@fysik.dtu.dk)

The reduction of molecular nitrogen to ammonia is one of the most challenging problems in catalysis, both because of the high stability of N<sub>2</sub>, and the high demand for ammonia, one of the most ubiquitous industrial chemicals. It is primarily used in the production of artificial fertilizers, which are crucial for supporting a growing global population and largely responsible for the population boom in the 20th century. Due to the challenging nature of the reaction, ammonia is still produced in the highly energy consuming Haber-Bosch process, which requires high temperature and pressure, necessitating production in large, centralized plants. The modest energy efficiency and high demand for ammonia result in 1 % of the world's energy being used for ammonia production. The electrochemical production of ammonia is an attractive alternative where electrochemical potential could be used to drive the reaction, enabling on-site production using electricity from green energy sources. In this work, a critical consideration of the state-of-the-art will be presented and an experimental protocol that can address the most common problems in nitrogen reduction benchmarking is suggested. The reduction of N<sub>2</sub> is theoretically predicted to be possible at very negative potentials and it competes against the much more facile hydrogen evolution reaction, resulting in low faradaic efficiencies. Ammonia is usually quantified using the indophenol method, which can detect it at ppb levels. However, ammonia is ubiquitous in the environment and can easily contaminate electrochemical setups and samples. Therefore, it is difficult to determine the source of measured ammonia with certainty and reliably benchmark low activities. These problems necessitate extreme scrutiny for the assessment of the reaction. The necessity of background measurements will be demonstrated along with the need for rigorous quantification of the catalytic activity in terms of turnover frequency, yield rate, quantity, and concentration of detected ammonia. Isotope labelled <sup>15</sup>N<sub>2</sub> experiments will be shown to enable the differentiation between ammonia originating from the reduction of N<sub>2</sub> gas introduced to the system and sources of contamination. The synthesized ammonia can subsequently be detected and quantified using NMR, providing robust benchmarks. An additional concern, which is generally not addressed in the literature, will be discussed - the fact that ammonia and easily reducible nitrogen oxides are a common and an experimentally significant impurity in isotope labelled <sup>15</sup>N<sub>2</sub> nitrogen gas. The developed protocol is then applied to test for the most attractive candidates for nitrogen reduction predicted by theory, in both aqueous and non-aqueous electrolytes and an example of successful electrochemical nitrogen reduction will be presented.

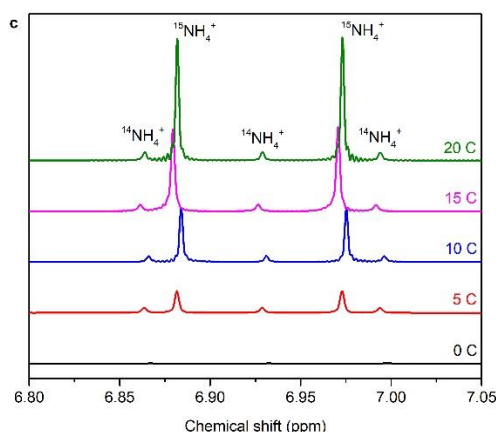

Figure 1: NMR spectra of samples containing isotope labelled <sup>15</sup>NH<sub>3</sub> originating from the reaction

## On the electrochemical reduction of molecular oxygen in coexisting equilibrium phases of solutions of limited miscibility

Gyöző G. Láng<sup>1</sup>, Mária Ujvári<sup>1</sup>

<sup>1</sup>Department of Physical Chemistry, Eötvös Loránd University, H-1117 Budapest, Pázmány P. s. 1/A, Hungary  
[langgyg@chem.elte.hu](mailto:langgyg@chem.elte.hu)

It is well known from thermodynamics that the chemical potential of each component is the same in all phases coexisting at equilibrium. Equilibrium also implies that the thermodynamic interfacial properties of a given electrode (*e.g.* a metal in contact with the liquid phase) in either equilibrium phase of a partially miscible system are the same. Experimental results with mercury and gold metals support this expectation [1-3]. Although from the similarities of thermodynamic characteristic no structural uniformity of the interface follows, the surface tension and differential capacity data measured in the double layer regions indicate that the structure of the double layer formed in the equilibrium phases might be similar. However, many physical properties (*e.g.* density, composition, viscosity, conductivity) of the coexistent equilibrium phases are widely different. It means, that according to the thermodynamic considerations the investigation of electrochemical processes in such media may give an unique opportunity to identify physicochemical parameters which are directly connected with and determined by either the equilibrium properties of the system only, or/and depend on other properties of the phases, as well. Especially, very interesting conclusions are expected from the comparison of polarization curves and impedance spectra taken in the equilibrium phases using the same electrode metal. The electrochemical reduction of molecular oxygen on polycrystalline Au has been studied in air saturated equilibrium phases of the 2-methylpropan-1-ol (isobutyl alcohol) – water – sulfuric acid model system by the rotating disk technique combined with cyclic voltammetry and impedance spectroscopy. Characteristic physicochemical properties of the equilibrium phases have been measured directly (*e.g.* composition, density, dynamic viscosity, etc.) or have been evaluated from impedance data by CNLS fitting (diffusion coefficient of O<sub>2</sub>, rate constants, transfer coefficients, double layer capacity). It should be noted that besides the fact that investigation of the properties of partially miscible systems is exciting from a theoretical point of view, the reduction of oxygen in different media has received a continuous interest regarding its importance in different practical applications.

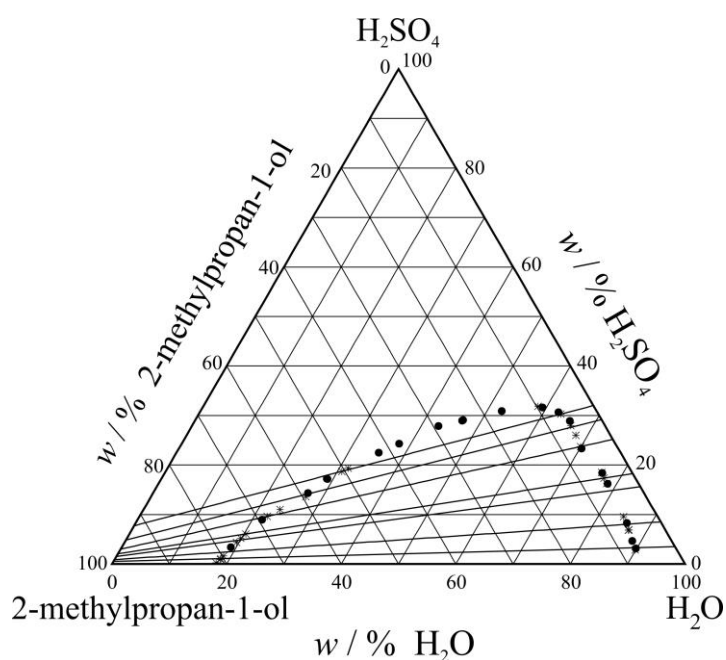

Fig. 1. Phase diagram of the ternary system water – isobutanol – sulfuric acid

**Acknowledgement:** Support from the Hungarian Scientific Research Fund - OTKA, the National Research, Development and Innovation Office – NKFI (grant No. K 129210) is gratefully acknowledged.

### References

1. K.E. Heusler, G. Láng, *Electrochim. Acta* 42 (1997) 747 ([https://doi.org/10.1016/S0013-4686\(96\)00341-6](https://doi.org/10.1016/S0013-4686(96)00341-6)).
2. G. Láng, K.E. Heusler, *J. Chem. Soc., Farad. Trans.* 93(4) (1997) 583 (<https://doi.org/10.1039/A606627E>).
3. G.G. Láng, C.A. Barbero, *Laser Techniques for the Study of Electrode Processes*, Springer-Verlag, Berlin, Heidelberg, 2012 (<https://doi.org/10.1007/978-3-642-27651-4>).

## Investigation of the electrochemical behaviour of bisphenol A on gold in contact with 0.1 M aqueous NaClO<sub>4</sub> solution

Krisztina J. Szekeres, Éva Fekete, Gyöző G. Láng

Department of Physical Chemistry, Institute of Chemistry, Laboratory of Electrochemistry and Electroanalytical Chemistry, Eötvös Loránd University, Pázmány Péter sétány 1/A, 1117 Budapest, Hungary  
[szekkriszt@caesar.elte.hu](mailto:szekkriszt@caesar.elte.hu)

Bisphenol A (BPA, 4,4'-(propane-2,2-diyl)diphenol or 2,2-bis(4-hydroxyphenyl)propane is an organic synthetic compound with two unsaturated phenolic rings. It is widely used in plastic industry as a monomer to produce epoxy resins, polycarbonate plastics, and flame retardants. Phenolic compounds as BPA are toxic to humans, animals and plants and despite its widespread use, many reports claim that BPA can leach out from plastic products such as food packaging materials and act as an endocrine disrupting chemical (EDC). The understanding of the electrochemical properties of BPA is critical for the design and successful application of electrochemical BPA sensors. According to the literature, the electrochemical oxidation of phenolic compounds (including bisphenol A) via the deposition of electropolymerized films often causes the inactivation of different electrodes. In this work a similar behavior was observed in the gold | 0.1 M sodium perchlorate + 100 ppm BPA system: during the cycling of the electrode potential a thin polymer layer was formed on the electrode. Electrochemical quartz crystal microbalance (EQCM) coupled with cyclic voltammetry was used to monitor in situ the surface changes and the film buildup process (Fig.1). The layer was measured ex situ by electrochemical impedance spectroscopy (EIS). Impedance measurements suggest that the polymer is practically electrochemically inactive at the applied potentials. Scanning electron microscopy with a focused Ga ion beam (SEM-FIB) was used for the study of the structure and the morphology of the deposited polymer film. According to the SEM images, the surface of the polymer layer is quite smooth, apart from some small holes and cracks [1]. The results show that polymerization and degradation of the BPA monomer may occur simultaneously during its electrochemical oxidation.

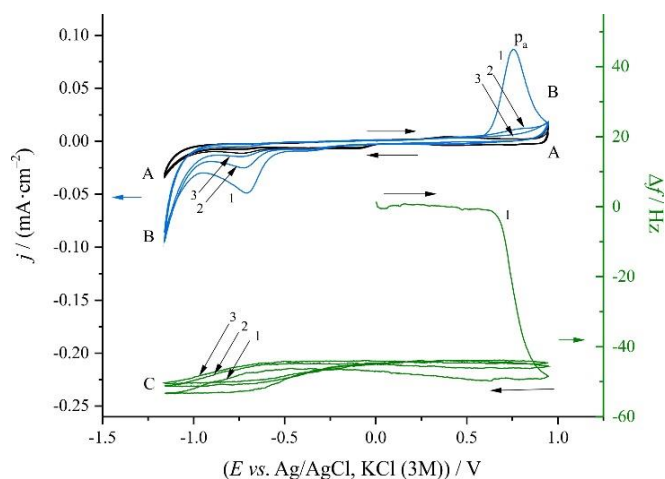

Figure 1. Cyclic voltammograms (A, B) and the corresponding changes in the EQCM frequency (C) recorded at a Au/TiO<sub>2</sub> quartz crystal (surface area A = 0.36 cm<sup>2</sup>) in contact with (A) 0.1 M NaClO<sub>4</sub>; (B, C) 100 ppm bisphenol A / 0.1 M NaClO<sub>4</sub> aqueous solutions. Sweep rate:  $\nu = 20 \text{ mV}\cdot\text{s}^{-1}$ ,  $E = -1.16 \text{ V} - 0.95 \text{ V vs. Ag|AgCl, KCl (3M)}$ . ( $\Delta f$ : frequency change of the quartz oscillator,  $E$ : electrode potential,  $j$ : current density.)  $E(p_a) = 0.76 \text{ V vs. Ag|AgCl, KCl (3M)}$ .

**Acknowledgment:** This work was supported by the ÚNKP-18-3 New National Excellence Program of the Ministry of Human Capacities and by NKFI - OTKA (grant No. K 129210). The research within project No. VEKOP-2.3.2-16-2017-00013 was supported by the European Union and the State of Hungary, co-financed by the European Regional Development Fund.

### References

1. K.J. Szekeres, É. Fekete, M. Ujvári, S. Vesztergom, V.V. Kondratiev, G.G. Láng, *Russ. J. Electrochem.*, submitted.

# **8<sup>th</sup> Kurt Schwabe Symposium**

## Kurt Schwabe – Name given of an international symposium

Vonau Winfried

*Kurt Schwabe Institute, Kurt-Schwabe-Straße 4, 04736 Waldheim, Germany*  
[winfried.vonau@ksi-meinsberg.de](mailto:winfried.vonau@ksi-meinsberg.de)

The Kurt Schwabe Symposium was established in 1993 by Erika Kálmán in memoriam of Kurt Schwabe (1905-1983), a famous German electrochemist. In the following some stations of Schwabes life are briefly sketched: After attending school in his hometown Reichenbach, he completed a study of chemistry in Dresden. In 1924 he finished his diploma thesis on the subject of catalytic decomposition and oxidation of formic acid under the supervision of Erich Müller. He completed his doctorate in 1928 with a dissertation on adsorption capacity of platinum metals for hydrogen, followed by his habilitation in 1933 dealing with anodic behaviour of metals in saturated solutions of their salts.

1934 Schwabe was appointed as honouree lecturer and 1939 as associate professor for chemical technology at the Dresden technical college. Mainly he worked as chemist in chief of the paper mill Kübler & Niethammer in Meinsberg during this time. In addition, from 1938 – 1945 he acted as expert for cellulose and paper industry in Berlin.

1945 he bought parts of buildings of the company Kübler & Niethammer and founded a privat research institute with associated production department. The application orientated research activities carried out there until his death generally concerned electrochemical sensors and measurement equipment as well as devices for corrosion investigations. Often salable products could be developed.

After Schwabe's death the institute with about 230 employees was assigned to the former Ministry of Science and Technology of the GDR. Since 1993 it operates under the name Kurt Schwabe Institute for measurement and sensor technology under the authority of the Saxon Ministry for Science and Arts.

In 1949 Schwabe himself was appointed as professor of electrochemistry and physical chemistry at the Dresden technical college. From 1961 – 1963 he was the first rector of the later Dresden university of technology and has held a number of further positions at national and international levels. E.g., he was director of the Institute of radiochemistry in Rossendorf, president of the Saxony Academy of Sciences in Leipzig, director of the institute of corrosion protection, vice president of the Academy of Sciences of the GDR in Berlin and of the international society of electrochemistry. Schwabe was author and co-author of 484 scientific publications, he filed 40 patents and supervised 545 graduands, 414 Ph.D. students and 51 habilitands. Beside the above mentioned institute there are two foundations bearing his name. Furthermore, three organisations awarding a Schwabe prize.

The Kurt Schwabe symposium initiated by his doctoral student Erika Kálmán has taken place seven times so far and focused on different branches of electrochemistry:

- 1<sup>st</sup> Kurt Schwabe Corrosion Symposium, August 25-27, 1993, Tata, Hungary
- 2<sup>nd</sup> Kurt Schwabe Corrosion Symposium, April 17-19, 1997, Dresden, Germany
- 3<sup>rd</sup> Kurt Schwabe Corrosion Symposium, August 29-September 2, 2000, Zakopane, Poland
- 4<sup>th</sup> Kurt Schwabe Corrosion Symposium, Juni 13-17, 2004, Helsinki, Finland
- 5<sup>th</sup> Kurt Schwabe Symposium from Corrosion to Semiconductors, Mai 24-28, 2009, Erlangen-Nürnberg, Germany
- 6<sup>th</sup> Kurt Schwabe Symposium, Surface Analysis and Material Engineering in Corrosion Science and Electrochemical Technologies, September 16-19, 2013, Krakow, Poland
- 7<sup>th</sup> Schwabe Symposium, Corrosion Science, Electroanalysis, Electrochemical Sensors and Electrochemical Engineering, September 4-7, 2016, Mittweida, Germany

## Coulometric titration of oxygen in the picomol range

Alexander Herms<sup>1</sup>, Jingying Yao<sup>1</sup>, Jens Zosel<sup>1</sup>, Wolfram Oelßner<sup>1</sup>, Michael Mertig<sup>1,2</sup>

<sup>1</sup>Kurt-Schwabe-Institut für Mess- und Sensortechnik e.V. Meinsberg, 04736 Waldheim, Germany

<sup>2</sup>Professur für Physikalische Chemie, Mess- und Sensortechnik, TU Dresden, Dresden, Germany

[alexander.herms@ksi-meinsberg.de](mailto:alexander.herms@ksi-meinsberg.de)

Metal oxides are widely used in different fields, e.g. as cathode material in batteries or as solid electrolytes in fuel cells. For a better understanding of these materials, it is crucial to investigate the changes of oxygen stoichiometry at high temperatures and varying oxygen partial pressures ( $p(\text{O}_2)$ ) because their conductivity can depend on these parameters. For this purpose, often oxygen solid electrolyte coulometry (OSEC) [1,2] is used. State-of-the-art systems contain galvanostatically controlled zirconia-based pump cells up- and downstream of a heated sample reactor. With such a setup, however, it is not possible to quantify small amounts of exchanged oxygen in the  $p(\text{O}_2)$  range between  $10^{-5}$ ...0.1 Pa.

Recently, a new setup was described, as schematically shown in Figure 1, enabling coulometric oxygen titration experiments in basic  $p(\text{O}_2) < 0.3$  Pa with a lower limit of detection below 100 pmol  $\text{O}_2$  [3,4].

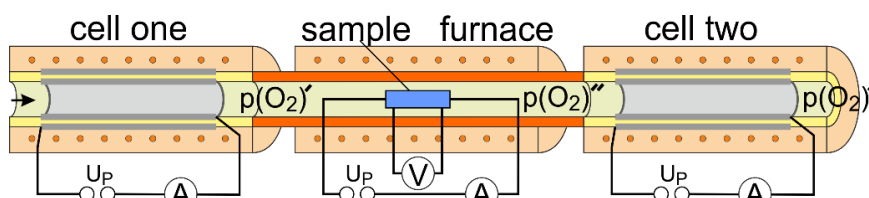

Figure 1. Setup for coulometric measurement of oxygen exchange of heated samples.

It consists of a gas mixing station for flow rate adjustment and gas pre-mixing, followed by a first YSZ flow-through cell (Zirox Sensoren und Elektronik GmbH, Greifswald, Germany (O2-DF28.0)). In this first cell the oxygen partial pressure  $p(\text{O}_2)$  of the carrier gas is precisely adjusted by applying a constant polarization  $U_p$  (cell one) versus a Pt/air reference electrode. The gas with fixed  $p(\text{O}_2)$  is guided into a sample furnace where the material of interest is heated to temperatures between 300-800 °C while its oxygen exchange with the surrounding gas atmosphere is measured. The exchanged oxygen is quantified by a second YSZ sensor at the furnace outlet by applying a constant polarization  $U_p$  (cell two) and a high-resolution measurement of the cell current.

Due to sealing modifications at the oxygen titration cell and at the sample furnace, the tightness of the system could be considerably increased. This improvement and the usage of an integrated control unit, as described in [5], enables a significant diminishment of the limit of detection for this setup down to amounts  $< 100$  pmol of exchanged oxygen for a  $p(\text{O}_2)$  of the carrier gas  $< 0.3$  Pa.

This contribution gives an insight in the system characteristics like oxygen dispersion, titration efficiency, lower limit of detection, and the influence of the flow rate on to these parameters is shown.

Furthermore, various experimental results are presented which demonstrate that the Faradaic oxygen titration with these YSZ cells is capable of detecting picomols of exchanged oxygen released in some seconds up to micromols of exchanged oxygen released in hours.

### References

1. V. Vashook, J. Zosel, U. Guth, *Journal of Solid State Electrochemistry* **16** (2012) 3401 – 3421 ([doi:10.1007/s10008-012-1876-3](https://doi.org/10.1007/s10008-012-1876-3))
2. M. Stöber, C. Cherkouk, T. Leisegang, M. Schelter, J. Zosel, J. Walter, J. Hanzig, M. Zschornak, S. Prucnal, R. Böttger, D. C. Meyer, *Crystal Research and Technology* **53** (2018) 1800004 (<https://doi.org/10.1002/crat.201800004>)
3. A. Herms, A., J. Yao, J. Zosel, J. V. Vashook, W. Oelßner, M. Mertig, *Journal of Sensors and Sensor Systems* **7** (2018) 621 – 625. (<https://doi.org/10.5194/jsss-7-621-2018>)
4. J. Zosel, A. Herms, J. Yao, P. Sood, A. Ruchets, U. Guth, M. Mertig, *Sensor Reviews* (2019) submitted
5. M. Schelter, J. Zosel, W. Oelßner, U. Guth, M. Mertig, *Sensors and Actuators B: Chemical* **187** (2013) 209-14 (<https://doi.org/10.1016/j.snb.2012.10.111>)

## In situ observation of crevice corrosion by a modified chemical imaging sensor system

Ko-ichiro Miyamoto<sup>1</sup>, Tatsuo Yoshinobu<sup>1,2</sup>

<sup>1</sup>Department of Electronic Engineering, Tohoku University

<sup>2</sup>Department of Biomedical Engineering, Tohoku University

[k-miya@ecei.tohoku.ac.jp](mailto:k-miya@ecei.tohoku.ac.jp)

In the study of corrosion, the pH value in the vicinity of a corroded metal surface and the morphological change of the surface are essential information. However, a direct observation of these can be challenging especially in the case of ‘crevice corrosion’, which occurs in a narrow gap between metal parts in underwater environments. Crevice corrosion is a potential hazard to marine infrastructure, because of the difficulty of detection and non-linear propagation of the damage.

Recently, we proposed monitoring of crevice corrosion<sup>1-3</sup> by a chemical imaging sensor<sup>4</sup>, which is based on the field effect in semiconductor. It can visualize the pH distribution without any colour reagent, and has been applied to various applications<sup>5</sup>. The flat surface of the sensor is well-suited to form a crevice by contacting a metal test piece, inside which the pH distribution can be monitored label-free<sup>1-3</sup>. The local pH value inside the crevice decreases drastically from neutral to strong acidic condition (< pH2) in the course of corrosion. As shown in Fig. 1a, a circuit for polarization was integrated with the measurement electronics of the chemical imaging sensor to realize collection of chemical images during an accelerated crevice corrosion<sup>2</sup>.

However, the morphology of the corroded area could be observed only after dismantling the test piece. In this study, a novel measurement system was constructed for in situ and simultaneous observation of both the pH distribution and propagation of crevice corrosion. Figure 1b is a schematic view of the setup, in which the shorter wavelength of light (850 nm) is used for mapping the pH value, while the longer wavelength of light (1550 nm) is used for mapping the surface roughness. Time-lapse measurements of pH and roughness were conducted by combining the optical setup in Fig. 1b with the circuit in Fig. 1a.

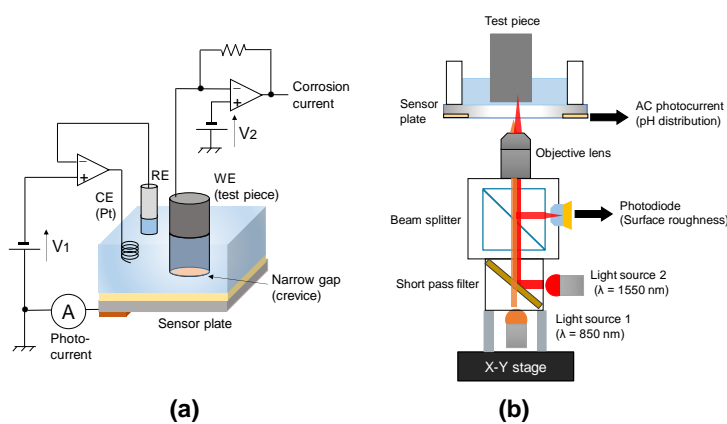

Figures1: (a) Combination of the chemical imaging sensor and the circuit for polarization. (b) The modified measurement system to monitor the pH distribution and the surface roughness simultaneously.

### References

1. K. Miyamoto, S. Sakakita, T. Wagner, M. J. Schöning and T. Yoshinobu, *Electrochimica Acta* **183** (2015) 137-142. (<https://doi.org/10.1016/j.electacta.2015.07.184>)
2. K. Miyamoto, S. Sakakita, C. F. Werner and T. Yoshinobu, *physica status solidi A* **215** (2018) 1700963. (<http://doi.org/10.1002/pssa.201700963>)
3. “Sensors and techniques for visualization and characterization of local corrosion” K. Miyamoto and T. Yoshinobu, *Japanese Journal of Applied Physics* (2019) in press.
4. M. Nakao, T. Yoshinobu and H. Iwasaki, *Sensors and Actuators B* **20** (1994) 119-123. ([https://doi.org/10.1016/0925-4005\(93\)01199-E](https://doi.org/10.1016/0925-4005(93)01199-E))
5. K. Miyamoto and T. Yoshinobu, *Sensors and Materials* **28** (2016) 1091-1104. (<https://doi.org/10.18494/SAM.2016.1364>)

## Corrosion screening of dysprosium-magnesium-zinc alloys for bioresorptive implants

Dominik Recktenwald<sup>1,2</sup>, Cezarina Cela Mardare<sup>1,2</sup>, Andrei Ionut Mardare<sup>1</sup>, Achim Walter Hassel<sup>1,2</sup>

<sup>1</sup>Johannes Kepler University Linz, Institute for Chemical Technology of Inorganic Materials,  
Altenberger Straße 69, 4040 Linz, Austria.

<sup>2</sup>Christian Doppler Laboratory for Combinatorial Oxide Chemistry, Altenberger Straße 69, 4040 Linz, Austria.  
[Dominik.Recktenwald@jku.at](mailto:Dominik.Recktenwald@jku.at)

Alloys have become a major material class for biomedical applications.[1] Mg-Zn alloys in particular are interesting as materials for stents and non-permanent bone supports on account of their bioresorbability.[2] The corrosion products  $Mg^{2+}$  and  $Zn^{2+}$  play a vital role in many enzymatic processes in the human body and they are not considered a health hazard.[3] The main challenge in Mg-Zn alloys is the high corrosion rate and the corresponding development of  $H_2$  inside the body. While this is less of a problem in stents due to the steady gas removal by the blood stream, at bone level only a limited amount of gas can be transported in a given time interval resulting in large gas pockets.[4] To reduce this problem the corrosion reaction must be suppressed by coatings or alloying with other metals.[4,5] Co-alloying, besides adding new properties, opens a way to tune the alloys properties by minor changes in the final composition. Mg-Rare Earth alloys for example show an increased corrosion resistance even in vivo.[6] However in order to find the right composition displaying the desired properties a screening process on a large compositional spread is often necessary. Due to the cosine law of thermal evaporation it is easily possible to generate a combinatorial library of thin films alloys on a single sample. Scanning droplet cell microscopy[7] offers a fast and systematic way to analyse a large quantity of alloy samples in a short time, thereby enabling an efficient screening process.

A ternary Dy-Mg-Zn material library has been produced originating from pure elements using physical vapour deposition (PVD). Energy dispersive x-ray spectroscopy (EDX) measurements showed a composition range for Dy from 2.5 – 0 at%, for Mg from 91 – 55 at% and for Zn from 44 – 9 at%. XRD exhibited no visible peaks in the Mg rich region and small signals in Mg poor areas. SEM images displayed a topographical change from plates to grains by increasing Zn content and simultaneously a flattening by increasing Dy content. Electrochemical impedance spectroscopy (EIS), polarisation curves and cyclic voltammetry (CV) measurements have been conducted with scanning droplet cell microscopy (SDCM) coupled to an inductively coupled plasma optical emission spectroscope (ICP-OES) to measure both the used current and the resulting dissolution of dysprosium, magnesium and zinc ions in modified simulated body fluids ( $SrCl_2$  instead of  $MgCl_2$ ). EIS measurements, polarisation curves and CVs showed a constant low  $Mg^{2+}$  dissolution of  $5 \text{ ng s}^{-1} \text{ cm}^{-2}$  ( $\approx 550 \text{ } \mu\text{g month}^{-1} \text{ cm}^{-2} H_2 \approx 14 \text{ mL month}^{-1} \text{ cm}^{-2} H_2$ ) until approximately 20 at% Zn was reached. At higher concentrations the constant dissolution increased to over  $10 \text{ ng s}^{-1} \text{ cm}^{-2}$  and peaks correlating with the applied potential could be observed. Zinc peaks sometimes appeared alongside these magnesium peaks while dysprosium dissolution remained below the detection limit.

### References

1. G. A. dos Santos, *Adv. Tissue Eng. Regen. Med.* **3** (2017) 300-302 (<https://doi.org/10.15406/atroa.2017.03.00054>)
2. M. P. Staiger, A. M. Pieatak, J. Huadmai, G. Dias, *Biomaterials* **27** (2006) 1728-1734 (<https://doi.org/10.1016/j.biomaterials.2005.10.003>)
3. S. Dhivya, J. Ajita, N. Selvamurugan, *J. Biomed. Nanotechnol.* **11** (2015) 1675-1700 (<https://doi.org/10.1166/jbn.2015.2115>)
4. Y. Yan et al., *Mat. Sci. Eng. C* **74** (2017) 582-596 (<https://doi.org/10.1016/j.msec.2016.12.132>)
5. L. Li, J. Gao, Y. Wang, *J. Surf Coat Technol* **185** (2004) 92-98 (<https://doi.org/10.1016/j.surfcoat.2004.01.004>)
6. F. Witte et al., *Biomaterials* **26** (2005) 3557-3563 (<https://doi.org/10.1016/j.biomaterials.2004.09.049>)
7. J. P. Kollender et al., *J. Electroanal. Chem.* **740** (2015) 53-60 (<https://doi.org/10.1016/j.jelechem.2014.12.043>)

## Adrenaline biosensing – from macroelectrode to chip-based biosensor to support tumor diagnosis

Denise Molinnus<sup>1,2</sup>, Petra Siegert<sup>1</sup>, Holger S. Willenberg<sup>3</sup>, Arshak Poghossian<sup>1,4</sup>, Michael Keusgen<sup>2</sup>, Michael J. Schöning<sup>1,4</sup>

<sup>1</sup>*Institute of Nano- and Biotechnologies (INB), FH Aachen, Campus Jülich, Jülich, Germany*

<sup>2</sup>*Institute of Pharmaceutical Chemistry, Philipps-University Marburg, Marburg, Germany*

<sup>3</sup>*Division of Endocrinology and Metabolism, Rostock University Medical Center, Rostock, Germany*

<sup>4</sup>*Institute of Complex Systems 8 (ICS-8), Forschungszentrum Jülich GmbH, Jülich, Germany*

[molinnus@fh-aachen.de](mailto:molinnus@fh-aachen.de)

Patients older than 40 years have a higher risk to come down with adrenal gland tumors, which are often responsible for drug-resistant high blood pressure. The only reliable way to diagnose these tumors is the so-called adrenal venous sampling procedure (AVS). During this examination, blood samples from adrenal veins were extracted, which is quite challenging due to the small size of the veins. To facilitate AVS and to guarantee the right blood samples, adrenal veins' adrenaline concentration can be measured to confirm the successful insertion of the catheter tip in the right vein, since there is a concentration difference between adrenal blood (>100 nM) and peripheral blood (1-5 nM).

Two different detection methods are presented by using substrate recycling principle:

1) The first one is based on a modified oxygen sensor with a bi-enzyme membrane. A laccase for the oxidation of adrenaline to adrenochrome under oxygen consumption is applied. As a second enzyme, a PQQ (pyrroloquinoline quinone) -glucose dehydrogenase guarantees the reduction of adrenochrome back to adrenaline [1]. The oxygen consumption represents the measured quantity and is directly proportional to the adrenaline concentration. With this bi-enzyme biosensor, a lower detection limit of 1 nM could be reached in both, buffer solution as well as in patients' blood samples.

2) A chip-based biosensor is used to miniaturize the measurement set-up with the enzyme PQQ-glucose dehydrogenase realizing the bioelectrocatalytical measurement principle [2]. Here, adrenaline is oxidized directly at the sensor surface to adrenochrome, followed by the reduction reaction of adrenochrome back to adrenaline that is catalyzed by the enzyme. After several optimization steps, first experiments demonstrated the possible application of the chip-based biosensor to detect the adrenaline concentration difference between adrenal bold and peripheral blood during AVS.

### References

1. F. Lisdat, U. Wollenberger, A. Makower, H. Hörtnagl, D. Pfeiffer, F.W. Scheller, *Biosens. Bioelectron.*, 12, (1997) 296-303.
2. F. Lisdat, W.O. Ho, U. Wollenberger, F.W. Scheller, T. Richter, U. Bilitewski, *Elektroanal.*, 12, (1998) 803-807.

## Electrooxidation of nucleobases on disposable electrodes investigated by electrochemistry-capillary electrophoresis-mass spectrometry

Thomas Herl, Daniel Böhm, Frank-Michael Matysik

University of Regensburg, Universitätsstraße 31, 93053 Regensburg, Germany

[Thomas.Herl@chemie.uni-regensburg.de](mailto:Thomas.Herl@chemie.uni-regensburg.de)

Nucleobases are important analytical targets for the investigation of DNA damage and mutations. Hereby, electroanalytical techniques such as cyclic voltammetry, differential pulse voltammetry, or square-wave voltammetry are often considered as cheap alternatives to expensive and time-consuming instrumental methods like GC or HPLC demanding complex sample preparation and expensive devices [1]. However, in this context understanding the mechanism of electrode processes is of fundamental interest.

Capillary electrophoresis in combination with screen-printed electrodes is an elegant method for online investigation of electrochemical reactions. The injection into the separation system can be carried out directly from the electrode surface during oxidation or reduction without the risk of electrode fouling as the electrodes can easily be replaced after each measurement [2]. Detection by electrospray ionization and time-of-flight mass spectrometry (ESI-TOF-MS) allows for identification of generated product species and is the basis for elucidation of electrochemical redox mechanisms.

In this contribution, the electrooxidation of cytosine and thymine on commercial screen-printed carbon electrodes was investigated by online electrochemistry-capillary electrophoresis-mass spectrometry (EC-CE-MS). After electrochemical characterization by cyclic voltammetry in MS-compatible electrolytes, oxidation products were evaluated at different oxidation and separation conditions. The oxidation of cytosine led to the formation of 6-hydroxy-5-hydroperoxy-5,6-dihydrocytosine as main product under the present conditions [3]. Thymine formed a dimeric species upon oxidation.

### References

1. A. Brotons, F. J. Vidal-Iglesias, J. Solla-Gullón, J. Iniesta, *Anal. Methods* **8** (2016) 702-715.
2. P. Palatzky, A. Zöpfl, T. Hirsch, F.-M. Matysik, *Electroanalysis* **25** (2013) 117-122.
3. T. Herl, L. Taraba, D. Böhm, F.-M. Matysik, *Electrochem. Commun.* **99** (2019) 41-45.

## Electrochemical biosensors for on-line monitoring of biogas processes

Johanna Pilas<sup>1,2</sup>, Shahriar Dantism<sup>1,3</sup>, Desiree Röhlen<sup>1</sup>, Thorsten Selmer<sup>1</sup>, Torsten Wagner<sup>1</sup>,  
Michael Keusgen<sup>2</sup>, Patrick Wagner<sup>3</sup>, Michael J. Schöning<sup>1,4</sup>

<sup>1</sup>*Institute of Nano- and Biotechnologies (INB), FH Aachen, Jülich, Germany*

<sup>2</sup>*Department of Pharmaceutical Chemistry, Philipps-Universität Marburg, Marburg, Germany*

<sup>3</sup>*Department of Physics and Astronomy, KU Leuven, Leuven, Belgium*

<sup>4</sup>*Institute of Complex Systems (ICS-8), Forschungszentrum Jülich GmbH, Jülich, Germany*  
[schoening@fh-aachen.de](mailto:schoening@fh-aachen.de)

Monitoring of biogas processes represents an important issue for stable operation and efficient conversion of the digested material into methane. In this context, controlling and analysis of several key parameters might be helpful to operate such processes with high yield and allows avoiding disturbances or even process downtimes in biogas plants.

Two complementary biosensor-based array approaches will be presented:

- 1) An amperometric biosensor array has been developed for simultaneous detection of four intermediates, namely formate, ethanol, d-lactate and l-lactate. The biosensor array comprises bi-enzymatic systems of nicotinamide adenine dinucleotide (NAD<sup>+</sup>)-dependent dehydrogenases for the particular analytes in combination with a diaphorase from *Clostridium kluyveri*. The successful application of this electrochemical biosensor array is demonstrated in real samples such as maize silage, inoculum and fermentation sludge from different biogas plants at different process stages.
- 2) The second approach is based on a light-addressable potentiometric sensor (LAPS) array enabling to study the metabolic activity of different model microorganisms such as *Corynebacterium glutamicum*, *Escherichia coli* and *Lactobacillus brevis*. The test microorganisms have been investigated with regard to their cellular metabolization after glucose uptake. With the knowledge about the acidification behaviour of each microorganism on the biosensor surface a characteristic calibration matrix can be realized that might serve as a basis for further-on multi-variate analysis correlated with the status of the biogas process.

*Acknowledgements:* The authors thank the German Federal Ministry of Food and Agriculture (BMEL) for financial support of the project (FKZ: 22006613).

## Pulse polarization measurements on the system Pt|YSZ by varying the polarization voltage

Nils Donker<sup>1</sup>, Anastasiya Ruchets<sup>2</sup>, Daniela Schönauer-Kamin<sup>1</sup>, Jens Zosel<sup>2</sup>, Ulrich Guth<sup>2</sup>, Ralf Moos<sup>1</sup>

<sup>1</sup>Department of Functional Materials, University of Bayreuth, 95440 Bayreuth, Germany

<sup>2</sup>Kurt-Schwabe-Institut für Mess- und Sensortechnik e.V. Meinsberg, 04736 Waldheim, Germany  
[funktionsmaterialien@uni-bayreuth.de](mailto:funktionsmaterialien@uni-bayreuth.de)

Most sensors for nitrogen oxides ( $\text{NO}_x$ ; NO and  $\text{NO}_2$ ) are based on potentiometric (equilibrium and non-equilibrium), amperometric, or impedancemetric principles to detect the concentration of  $\text{NO}_x$  in the atmosphere. All these methods have in common that they reach a steady state value at a constant atmosphere after certain time.

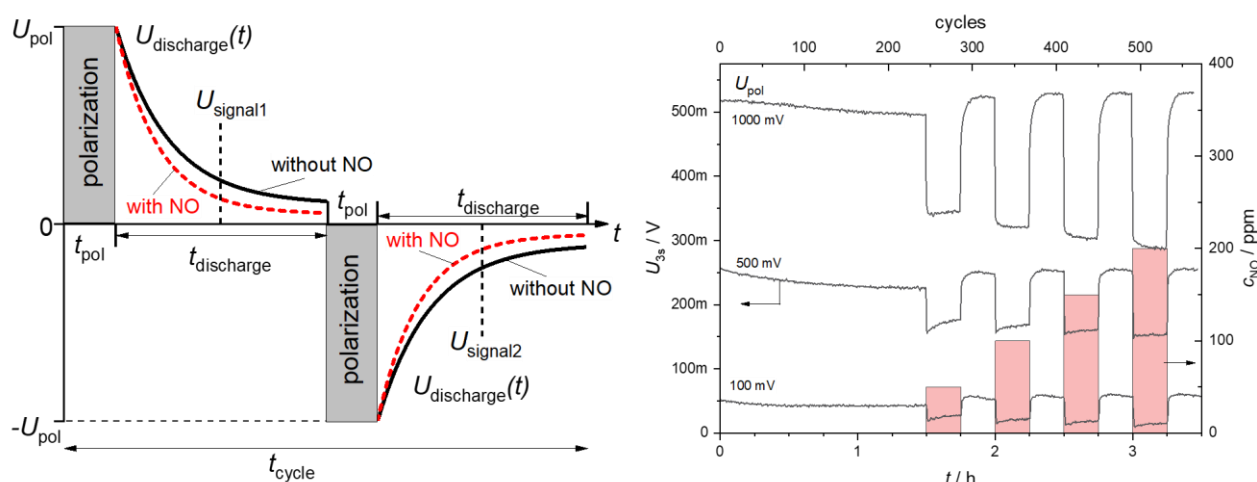

Fig. 1 – Sketch of a pulsed polarization cycle and b) measured sensor signal with  $t_{pol} = 1s$ ;  $t_{discharge} = 10s$  at  $T_{gas} = 400^\circ\text{C}$ ,  $c_{\text{CO}_2} = 10\%$ ,  $c_{\text{H}_2\text{O}} = 2\%$  as well as with 50, 100, 150 and 200 ppm NO. The voltages displayed ( $U_{signal}$ ) are measured 3 s after the beginning of the cycle

In contrast, the pulsed polarization method is a dynamic method and it utilizes the well-known Pt|YSZ-system. Platinum electrodes are screen-printed on both sides of a YSZ substrate for this purpose. Both sensor electrodes are exposed to the same gas atmosphere at the same temperature. Therefore, a potentiometric measurement would result in the voltage difference 0 V. To receive a signal, the sensor is brought out of its equilibrium state. In order to do this, the sensor is polarized with the polarization voltage  $U_{pol}$  for a duration  $t_{pol}$  (see Fig. 1a). The sensor then automatically discharges after the voltage source has been removed. It could be shown that the self-discharge accelerates strongly with increasing  $\text{NO}_x$  concentration [1]. After the discharge time  $t_{discharge}$ , the sensor is polarized again for the duration  $t_{pol}$ , but with the opposite sign  $-U_{pol}$ . Such a cycle with alternating polarization and intermediate discharge is schematically shown in Fig. 1a.

A sensor signal can be generated on the basis of the voltage values at a defined point in time in the cycle. Examples for such points in time are schematically marked as  $U_{signal1}$  and  $U_{signal2}$  in In the case of a perfectly symmetrical sensor design, the magnitude of these voltages is the same in terms of measurement accuracy. In this study, the operation of the pulse polarization with different polarization voltages shall be shown. It can be expected that the voltage and the resulting reactions will have a significant influence on the sensor signal. Some results measured at various polarization voltages (100, 500 and 1000 mV) are shown in Fig. 1b. Here, the voltages 3 seconds after the beginning of each cycle are displayed.

### References

1. S. Fischer, R. Pohle, E. Magori, M. Fleischer, R. Moos, Detection of NO by pulsed polarization of Pt | YSZ, Solid State Ionics 262 (2014) 288–291.

## Selective multi-gas measurements with solid electrolyte cells operated by cyclic voltammetry

Anastasiya Ruchets<sup>1</sup>, Nils Donker<sup>2</sup>, Daniela Schönauer-Kamin<sup>2</sup>, Ralf Moos<sup>2</sup>, Jens Zosel<sup>1</sup>, Ulrich Guth<sup>1</sup>, Michael Mertig<sup>1</sup>

<sup>1</sup>Kurt-Schwabe-Institut für Mess- und Sensortechnik e.V. Meinsberg, Kurt-Schwabe-Straße 4, 04736 Waldheim, Germany

<sup>2</sup>Department of Functional Materials, University of Bayreuth, 95440 Bayreuth, Germany

Up to now, solid electrolyte cells (SEC) have mainly been operated with stationary methods such as potentiometry, amperometry or coulometry. These methods are not suitable for selective determining of several redox-active components in gas mixture. In contrast, dynamic methods such as pulse polarization [1], CV [2] or impedance spectroscopy [3] can use different kinetics of the electrode reactions and allow detecting individual components independently on each other. This is demonstrated here with a commercial SEC based on yttria-stabilized zirconia, which was tested with cyclic voltammetry (CV) in gas mixtures containing redox-active gases such as H<sub>2</sub>, O<sub>2</sub> and H<sub>2</sub>O.

The test setup (Fig.1) was designed for adjustment and measurement of H<sub>2</sub>, O<sub>2</sub> and H<sub>2</sub>O gas concentrations. While the H<sub>2</sub> concentration was regulated by mass flow controllers (MFCs), the adjustment of O<sub>2</sub> and H<sub>2</sub>O was made by pumping O<sub>2</sub> with SEC 1. Cyclic voltammetric measurements were carried out at SEC 2 with a potentiostat at different scan rates (10-1000 mV/s), ranges (between -0.7 and -0.1 V vs. air reference), sensor temperatures (650-750 °C), gas flow rates (10-50 sccm) and gas concentrations of the components mentioned above in N<sub>2</sub> (0-200 vol.-ppm).

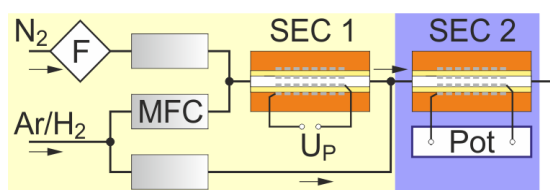

Fig.1. Sketch of the experimental setup, SEC = solid electrolyte cell, Pot = Potentiostat, MFC = Mass flow controller, F = O<sub>2</sub>/H<sub>2</sub>O/hydrocarbon-filter

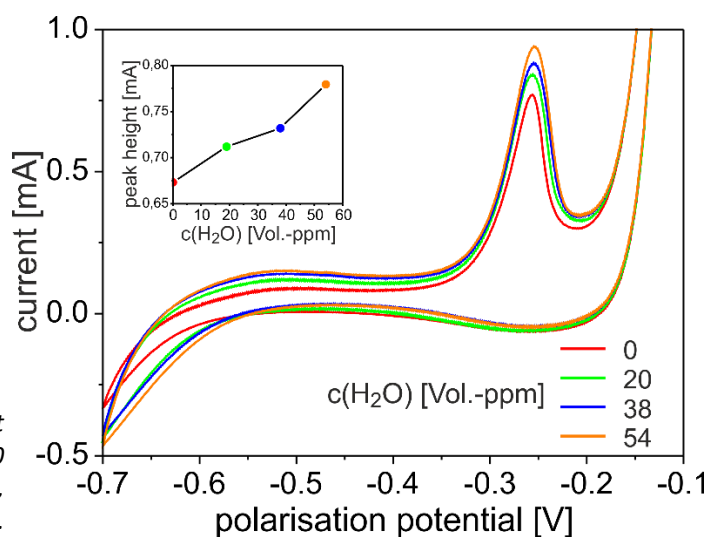

Fig.2. Voltammograms at SEC 2 according to Fig. 1 at different H<sub>2</sub>O-concentrations. SEC temperature = 750 °C, flow rate = 10 sccm, scan rate = 20 mV/s, c(H<sub>2</sub>) = 50 vol.-ppm, c(O<sub>2</sub>) = 0.2 vol.-ppm.

The water vapour influence was investigated in a concentration range from 0 to 54 vol.-ppm (Fig. 2). Increasing H<sub>2</sub>O concentrations lead to a slightly grow of the H<sub>2</sub>-related peak. The method thus allows the selective determination of H<sub>2</sub> at different H<sub>2</sub>O concentrations without sensitivity loss. The results show that both H<sub>2</sub> and O<sub>2</sub> could be measured quantitatively and with high selectivity at different H<sub>2</sub>O concentrations.

### References

1. S. Fischer et al., *Sensors and Actuators B: Chemical* 147 (2010) 780-785 <https://doi.org/10.1016/j.snb.2010.03.092>
2. M. Schelter et al., *Journal of Sensors and Sensor Systems*, 5 (2016) 319-324 <https://doi.org/10.5194/jsss-5-319-2016>
3. D. Franke et al., *Sensors and Actuators B: Chemical* 223 (2016) 723-729 <https://doi.org/10.1016/j.snb.2015.09.134>

## Comparison of different screen printed sensors based on carbon paste with incorporated Prussian blue nanoparticles as electrode material for hydrogen peroxide detection

Anne Müller<sup>1</sup>, Susan Sachse<sup>2</sup>, Manfred Decker<sup>1</sup>, Frank-Michael Matysik<sup>3</sup>, Winfried Vonau<sup>1</sup>

<sup>1</sup>Kurt-Schwabe-Institut für Mess- und Sensortechnik e.V. Meinsberg, Kurt-Schwabe-Straße 4, 04736 Waldheim, Germany

<sup>2</sup>Hochschule Mittweida, University of Applied Sciences, Technikumplatz 17, 09648 Mittweida, Germany

<sup>3</sup>Universität Regensburg, Universitätsstraße 31, 93053 Regensburg, Germany

[anne.mueller@ksi-meinsberg.de](mailto:anne.mueller@ksi-meinsberg.de)

The sensitive and selective determination of hydrogen peroxide (H<sub>2</sub>O<sub>2</sub>) is of great importance for biological, pharmaceutical, ecological and many other fields of application. Aim of these investigations is the development of screen printed electrodes for the determination of hydrogen peroxide in the gas phase condensing in small films of a collecting electrolyte. A common method for the determination of H<sub>2</sub>O<sub>2</sub> is the amperometric detection by use of electrochemical sensors with the redox mediator Prussian blue (PB) because of its excellent catalytic activity and selectivity for the reduction of hydrogen peroxide [1]. PB is usually applied to carbon electrodes by electrochemical deposition [2, 3], dip coating [4], inkjet printing [5, 6], or immobilization on functionalized surfaces [7, 8]. An alternative method suitable for mass production is the screen printing of the PB working electrode described by *Benedet et al.* [9]. According to this method, PB nanoparticles with a particle size of 20-30 nm were synthesized and incorporated into a carbon paste. The mixture of carbon and PB was screen printed on ceramic substrate as working electrode. Thus, it was possible to make specific modifications to the composition of the ingredients of the paste for the working electrode and to tailor the sensor surface and design according to the corresponding measurement requirements. In a range between 10<sup>-4</sup> M and 10<sup>-2</sup> M H<sub>2</sub>O<sub>2</sub> a linear correlation between the hydrogen peroxide concentration and the sensor signal can be determined.

### References

1. A. A. Karyakin, *Current Opinion in Electrochemistry* **5** (2017) 92-98 (<https://doi.org/10.1016/j.coelec.2017.07.006>)
2. A. A. Karyakin, E. E. Karyakina, L. Gorton, *Analytical Chemistry* **72** (2000) 1720-1723 (doi:10.1021/ac990801o)
3. A. A. Karyakin, E. A. Kuritsyna, E. E. Karyakina, V. L. Sukhanov, *Electrochimica Acta* **54** (2009) 5048-5052 (doi:10.1016/j.electacta.2008.11.049)
4. B. Haghghi, H. Hamidi, L. Gorton, *Sensors and Actuators B* **147** (2010) 270-276 (doi:10.1016/j.snb.2010.03.020)
5. J. Y. Hu, Y. P. Lin, Y. C. Liao, *Analytical Sciences* **28** (2012) 135-140
6. S. Cinti, F. Arduini, D. Moscone, G. Palleschi, A. J. Killard, *Sensors* **14** (2014) 14222-14234 (doi:10.3390/s140x0000x)
7. J. Chen, Y. Miao, X. Wu, *Colloid Journal* **69** (2007) 660-665 (doi:10.1134/S1061933X07050195)
8. J. H. Yang, N. Myoung, H. G. Hong, *Electrochimica Acta* **81** (2012) 37-43 (<http://dx.doi.org/10.1016/j.electacta.2012.07.038>)
9. J. Benedet, D. Lu, K. Cizek, J. La Belle, J. Wang, *Analytical Bioanalytical Chemistry* **395** (2009) 371-376 (doi:10.1007/s00216-009-2788-7)

## Investigations about the simultaneous potentiometric determination of pH-value and potassium amount in freshly sampled soil on-site on the field

Manfred Decker<sup>1</sup>, Arnold Wezel<sup>2</sup>, Robert Hasler<sup>2</sup>, Petra Teichmann<sup>1</sup>, Martin Schneider<sup>3</sup>, Winfried Vonau<sup>1</sup>

<sup>1</sup>*Kurt-Schwabe-Institut für Mess- und Sensortechnik e.V. Meinsberg, Kurt-Schwabe-Straße 4,  
04736 Waldheim, Germany*

<sup>2</sup>*Hochschule Mittweida, University of Applied Sciences, Technikumplatz 17, 09648 Mittweida, Germany*

<sup>3</sup>*Agricon GmbH, Im Wiesengrund 4, 04749 Ostrau, Germany*

[manfred.decker@ksi-meinsberg.de](mailto:manfred.decker@ksi-meinsberg.de)

A spatially resolved chemical analysis of some key parameters in the soil of extensive areas of farmland is an important precondition for a demand-oriented treatment and fertilization of the arable ground. Especially an exact knowledge of the distribution of pH-value and the amount of potassium, phosphate, and magnesium ions is very helpful for the establishment of a small meshed supply of the soil with fertilizers according the real need. This reduces the costs and decreases the ecological burden by the introduction of excessive nutritive substances. Up to now an analysis directly on the arable land is not possible. A space resolved sampling is followed by a cost- and labor-intensive determination of the targeted parameters in the lab. The presented results show the possibility to establish a potentiometric measuring system for the simultaneous determination of the pH-value and the potassium amount of earth samples directly on-site on the field.

Former investigations have shown that the use of robust antimony oxide electrodes is an adequate way to determine the pH-value of freshly sampled soil [1]. Before the potentiometric measurement the soil samples needed to be sieved and suspended in an appropriate extraction solution. The best agreement with the pH-results obtained by the method described in the German standard [2] has been achieved by the utilization of 0.01 M calcium chloride solution for suspending of the soil. Combined together in a small measuring cell with an adapted Ag/AgCl-based reference electrode the antimony oxide pH-sensor delivered a stable signal within 30 seconds.

This basic measuring setup will be extended by the integration of a polymer based ion-selective potassium probe. The suitability of this potentiometric technology for the determination of potassium in soil extraction solutions has been described by Adamchuk et al. [3]. To ensure a higher mechanical rigidity of these fragile membrane electrodes in the abrasive soil suspensions different ways for stabilization have been investigated. In addition, results concerning the optimization of ion-selective membrane composition and of the extraction solutions to ensure satisfactory results for the pH- and the potassium detection will be presented.

### References

1. M. Decker, S. Bause, P. Teichmann, M. Schneider, W. Vonau, *tm technisches messen* **84** (2017) 659-671
2. DIN ISO 10390: Soil quality – Determination of pH (ISO 10390:2005), DIN Deutsches Institut für Normung e. V. Berlin
3. V.I. Adamchuk, E.D. Lund, B. Sethuramasamyraja, M.T. Morgan, A. Dobermann, D.B. Marx, *Comput. Electron. Agr.* **48** (2005) 272-294

## Hydrodynamic scanning electrochemical microscopy

Timo Raith, Christian Iffelsberger, Stefan Wert, Frank-Michael Matysik

University of Regensburg, Universitätsstraße 31, 93053 Regensburg/D, Germany

[frank-michael.matysik@chemie.uni-r.de](mailto:frank-michael.matysik@chemie.uni-r.de)

In the frame of this contribution, forced convection in the context of scanning electrochemical microscopy (SECM) was investigated. Forced convection was generated either by integrating a high precision stirring device into the electrochemical cell or by a flow of the mediator solution through an electrochemical flow cell developed especially for this purpose. A description of the mandatory design aspects of the experimental setups is included.

Using a macroscopic working electrode as a substrate electrode, forced convection leads to the formation of a stable diffusion layer during amperometric experiments in contrast to a growing diffusion layer in quiescent solution. To characterize the effects of forced convection, the diffusion layer around a platinum substrate electrode integrated into the SECM cells was investigated utilizing chronoamperometric measurements and hydrodynamic SECM imaging in amperometric substrate generation-tip collection (SG/TC) mode. Both approaches proved the stability and the time-independency of the diffusion layer. Mathematical simulations using COMSOL Multiphysics were computed in order to investigate the velocity profile originating from the forced convection in the relevant region close to the substrate electrode.

In summary, two different approaches to apply forced convection to the SECM electrolyte were established and characterized [1, 2]. Both techniques offer interesting possibilities such as time-independent measurements in the context of the SG/TC mode or complementary measurements in hydrodynamic feedback mode [3, 4].

*Acknowledgments:* T. Raith gratefully acknowledges financial support from the Studienstiftung des deutschen Volkes.

### References

1. C. Iffelsberger, P. Vatsyayan, F. M. Matysik, *Anal. Chem.* **89** (2017) 1658-1664.
2. T. Raith, C. Iffelsberger, S. Wert, F. M. Matysik, *Monatsh. Chem.* **149** (2018) 1671–1677.
3. C. Iffelsberger, T. Raith, P. Vatsyayan, V. Vyskocil, F. M. Matysik, *Electrochim. Acta* **281** (2018) 494-501.
4. T. Raith, C. Iffelsberger, P. Vatsyayan, F.-M. Matysik, *Electroanalysis* (2018)  
(<https://doi.org/10.1002/elan.201800562>)

# **POSTER PRESENTATIONS**

# **Batteries and Electrochemical Energy Storage**

## Comparative study of synthesis way influence on the electrochemical behaviour of NMC 811

Krum Banov<sup>1,2</sup>, Iliyan Popov<sup>2</sup>, Todor Petkov<sup>2</sup>, Branimir Banov<sup>2,3</sup>

<sup>1</sup>University of Chemical Technology and Metallurgy (UCTM), Bulgaria

<sup>2</sup>Institute of Electrochemistry and Energy Systems "Academician Evgeni Budevski", Bulgaria

<sup>3</sup>European Polytechnical University, Bulgaria

[k.banov@iees.bas.bg](mailto:k.banov@iees.bas.bg)

Lithium-rich layered compounds attract recently ever-growing attention in the lithium ion batteries for electrical vehicles and prospective energy storage devices due to their high energy density. It is obviously clear that the electrochemical characteristics are widely influenced by the synthesis way.

The aim of the present work is to try to find the optimal route and appropriated starting precursors for preparation of NMC 811 with best electrochemical performances. As internal reference, it was chosen standard solid state reaction route and different precursors as  $\text{Li}_2\text{CO}_3$ ,  $\text{MnO}_2$ ,  $\text{CoCO}_3$ ,  $\text{NiCO}_3$ ,  $\text{LiAc}$ ,  $\text{MnAc}$ ,  $\text{CoAc}$  and  $\text{NiAc}$  (Ac - acetate). The same starting compounds have been used as also for the applied sol-gel method for preparation. Scanned temperature range for both synthesis ways was from 600°C to 800°C. Complete physicochemical characterizations have been performed including XRD, SEM/TEM, B.E.T., TGA/DTA and EDX. Preparations of test sample have been performed in Ar filled glow box with moisture content as low as 10ppm. Electrochemical tests have been effectuated in three electrode test cell with Li reference electrode. As electrolyte it was used standard LP30 electrolyte (1.0M  $\text{LiPF}_6$  in EC:DMC). Test charge discharge test protocol include constant current mode (CC) followed by constant voltage mode (CV) in a voltage window from 2.5V up to 4.5V. For better understanding electrochemical behaviour of AEM a slow cyclic voltammetry (SCV) was applied on test samples at a speed of 50  $\mu\text{V}$  per second.

Results show that when an appropriated starting precursor is used it is possible to obtain good electrochemical characteristic even when a SSR is used. The best results obtained are when sol-gel synthesis way is applied and the starting precursor is chosen between the acetic based compound as  $\text{LiAc}$ ,  $\text{MnAc}$ ,  $\text{CoAc}$  and  $\text{NiAc}$ . In this case the obtained reversible capacity on the first cycle is 250  $\text{mAh g}^{-1}$  and go down to 180  $\text{mAh g}^{-1}$  within 50 cycles, while the SSR is the method of preparation the initial capacity is lower – 220  $\text{mAh g}^{-1}$ . In this case displayed capacity on the 50<sup>th</sup> cycle is only 160  $\text{mAh g}^{-1}$ .

## Lithium diffusion properties of Fe<sub>3</sub>O<sub>4</sub> nanoparticles as different morphologies for anode materials of lithium ion batteries

Jong Seok Kim<sup>1</sup>, Dae Won Kim<sup>1</sup>, Tae Hyun Kim<sup>2</sup>

<sup>a</sup> School of Chemical Engineering, Chonbuk National University, Jeonju, Republic of Korea

<sup>b</sup> Department of Mechanical Engineering, Sogang University, Seoul, Republic of Korea

[js-kim@jbnu.ac.kr](mailto:js-kim@jbnu.ac.kr)

Fe<sub>3</sub>O<sub>4</sub> is extensively used in industrial production for products used daily life. Due to its high theoretical capacity of 942 mAhg<sup>-1</sup> has received a promising electrode material for the next generation of lithium ion batteries (LIB) with multiple electron transfer per metal cluster. However, lithiation and delithiation of Fe<sub>3</sub>O<sub>4</sub> can effectively reduce the obviously volume change that result in capacity fade and poor performance. In this study, hollow magnetite microspheres and Fe<sub>3</sub>O<sub>4</sub> nanoparticles have been synthesized by using a one-step hydrothermal method. Electrochemical impedance spectroscopy (EIS) was used to investigate the as-prepared and cycled cells from 1 cycle to 100 cycles in the charged state. The rate performance of Fe<sub>3</sub>O<sub>4</sub> nanoparticles was measured using a rate capability test. EIS showed that Fe<sub>3</sub>O<sub>4</sub> nanoparticle compare to its hollow microsphere had higher lithium diffusion coefficients during the charging.

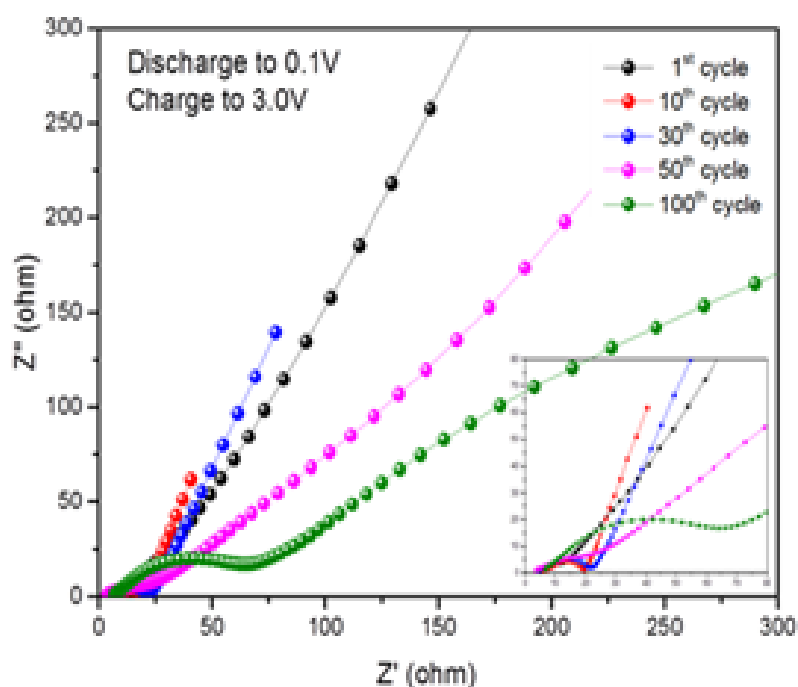

Fig. Nyquist plot of hollow Fe<sub>3</sub>O<sub>4</sub> electrode

### References

1. S. Xuan, Y. Wang, J. C. Yu, and K. Leung, Tuning the grain size and particle size of superparamagnetic Fe<sub>3</sub>O<sub>4</sub> microparticles, *Chem. Mater* **2009**, 21, 5079-5087.
2. L. Zhang, H. B. Wu, X. W. Lou, Iron-oxide-based advanced anode materials for lithium-ion batteries, *Adv. Energy. Mater* **2014**, 4,1300958.
3. B. B. Tian, J. Swiatowska, V. Maurice, C. Pereira-Nabais, A. Seyeux, and P. Marcus, Insight into Lithium Diffusion in Conversion-Type Iron Oxide Negative Electrode, *J. Phys. Chem C* **2015**, 119, 919-925.

## Silicon as anode for lithium-ion batteries

Matea Raić<sup>1,2</sup>, Lara Mikac<sup>1,2</sup>, Zoran Mandić<sup>3</sup>, Vedran Petrić<sup>3</sup>, Mile Ivanda<sup>1,2</sup>

<sup>1</sup>Center of Excellence for Advanced Materials and Sensing Devices, Research Unit New Functional Materials, Bijenička c. 54, Zagreb, Croatia

<sup>2</sup>Ruđer Bošković Institute, Division of Materials Physics, Laboratory for Molecular Physics and Synthesis of New Materials, Bijenička c. 54, Zagreb, Croatia

<sup>3</sup>Faculty of Chemical Engineering and Technology, Department of Electrochemistry, University of Zagreb, Croatia

[ivanda@irb.hr](mailto:ivanda@irb.hr)

The success of Li-ion batteries in the early 1960s took years of research and contribution of many scientists and engineers. Since then there are several electronic revolutions and still lithium-ion (Li-ion) cells are the most widely used as rechargeable battery system for portable electronic devices and electrical vehicles. It has many advantages like high energy density, long storage life, small volume, light weight, low self-discharge efficiency and non-memory effect. The most widely used anode is graphite whose lithiated compounds have stable phases up to the  $\text{LiC}_6$  stoichiometry corresponding to a theoretical specific capacity of 372 mAh / g<sup>[1]</sup>. In contrast, silicon possesses a very high theoretical capacity of 4200 mAh / g and can intercalate 4.4 Li into Si at high temperature to form  $\text{Li}_{15}\text{Si}_4$ <sup>[2]</sup>. Silicon also features a working potential around 0.4 V vs.  $\text{Li}^+/\text{Li}$  which is safer than operating potential of graphite (0.05 V vs.  $\text{Li}^+/\text{Li}$ ). Although silicon possesses all of these advantages, silicon based anodes suffer from huge volume expansion upon cycling ( $\approx 400\%$ ) causing electrode fracture and electrical isolation during repeated cycling<sup>[3]</sup>. Continuous volume changes cause the breaking-reformation of the solid electrolyte interphase (SEI) film which leads to consumption of lithium-ions and electrolyte. Exhaustion of the electrolyte causes the degradation of conductivity and induces fast capacity loss<sup>[4]</sup>. The porous structure can provide a large space to accommodate volume expansion and provide a large surface area for lithium-ion transport from electrolyte to silicon<sup>[5]</sup>. In this work we present silicon microparticles as anode material for lithium-ion battery. Anode was based on powder silicon mixed with polyvinylidene fluoride (PVDF) and conductive carbon black (CB) in N-Methyl-2-pyrrolidone (NMP). The structural properties of the anode was characterized by scanning electron microscope (SEM). Silicon particles were also characterized with gas adsorption measurements to obtain pore size distributions and size of particles. Capacitive properties and stability were determined by using cyclic voltammetry (CV), electrochemical impedance spectroscopy (EIS) and galvanostatic measurements. Our work provides promising results so we will continue our research.

### References

1. P. Simon, Y. Gogotsi, *Nature Mater* **7**, (2008) 845-854 ([https://doi.org/10.1142/9789814287005\\_0033](https://doi.org/10.1142/9789814287005_0033))
2. B. Kang, G. Ceder, *Nature* **458** (2009) 190-193 (<https://dx.doi.org/10.1038/nature07853>)
3. M. S. Wang, W. I. Song, I.Z. *ChemElectroChem* **2** (2015)1699-1706 (<https://doi.org/10.1002/celec.201500187>)
4. A. S. Arico, P. Bruce, B. Scrosati, J.M. Tarascon, W. Van Schalkwijk, *Nature Mater* **4** (2005) 366-377(<https://doi.org/10.1038/nmat1368>)
5. T. Ikonen, T. Nissinen, E. Pohjalainen, O. Sorsa, T. Kallio, V. P. Lehto, *Nature* **7** (2017) 7880 (<https://dx.doi.org/10.1038/s41598-017-08285-3>)

## Electrochemical performance of nanotube sodium titanate in hybrid Li-Mg ion cells

Sv. Veleva<sup>1</sup>, E. Zhecheva<sup>2</sup>, P. Polrolniczak<sup>3</sup>, A. Stoyanova<sup>1</sup>, R. Stoyanova<sup>2</sup>

<sup>1</sup> Institute of Electrochemistry and Energy Systems, Bulgarian Academy of Sciences, Sofia, 1113, Bulgaria

<sup>2</sup> Institute of General and Inorganic Chemistry, Bulgarian Academy of Sciences, Sofia, 1113, Bulgaria

<sup>3</sup> Institute of Non-Ferrous Metals, Division in Poznań, Central Laboratory of Batteries and Cells,  
61-362 Poznań, Poland

[svetlana\\_veleva@iees.bas.bg](mailto:svetlana_veleva@iees.bas.bg)

Lithium ion batteries are recognized as the most effective technology for energy storage with a variety of applications in different technological sectors. Irrespective of this achievement, they have some major disadvantages associated with their safety, cost and toxicity. The modern requirements for introducing more effective systems for energy storage require the searching of new approaches to develop safe batteries with higher energy density and lower costs.

One of the possible chemical approaches for increasing the capacity of the battery is by replacement of monovalent lithium ions with di- or trivalent ions while preserving the intercalation mechanism of the battery operation. In this regard, magnesium ion batteries are most attractive, since they operate by the same mechanism of reversible intercalation of  $Mg^{2+}$  ions. The replacement of monovalent  $Li^+$  with divalent  $Mg^{2+}$  ions will provoke a doubling of the battery capacity. Contrary to the intercalation of  $Li^+$ , the intercalation of  $Mg^{2+}$  is a kinetically limited process owing to the polarizing ability of the ions and the significant Coulomb interactions between "guest" ions and anionic groups of the "host" compound. The scientific challenge is how to shield these effects and what type of structural matrices should be selected to make the rapid and reversible intercalation of  $Mg^{2+}$  ion feasible.

The present study provides the first data on the electrochemical performance of nanotube sodium titanate as an anode material in hybrid Li-Mg ion cells. The sodium titanate with nanotube morphology is synthesized hydrothermally using NaOH and  $TiO_2$  (Fig. 1). The electrochemical performance of sodium titanate is first examined in half ion cells *versus* metallic Li anode and using two electrolyte compositions: magnesium

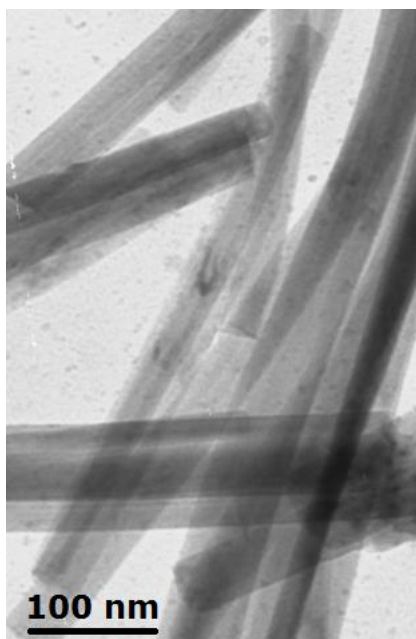

Figure 1. TEM image of hydrothermally prepared sodium titanate

electrolyte including 0.5 M solution of  $Mg(TFSI)_2$  in diglyme and lithium electrolyte containing 0.5 M  $Li(TFSI)_2$  in diglyme. Through detailed physicochemical characterization, it is found that nanotube sodium titanate is able to co-intercalate reversibly  $Mg^{2+}$  and  $Li^+$  ions at potential lower than 1.5 V *versus* Li/Li<sup>+</sup>. The electrochemical activity of sodium titanate as an anode material is further tested in full hybrid ion cell. This cell is constructed by a pairing sodium titanate as an anode and  $MgMn_2O_4$  spinel as a cathode. The best electrochemical performance is established when lithium electrolyte is used. The mechanism of the hybrid cell operation is discussed. These first studies could initiate further investigations focused on the design of full cells involving titanium and magnesium compounds as negative and positive electrodes.

*Acknowledgement:* The authors are grateful to the financial support from the National Science Fund of Bulgaria, Project DN09/13. The parts of the experiments were performed with equipment included in the National Infrastructure NI SEVE supported by the Ministry of Education and Science under grant agreement № DO1-160/28.08.18.

## Synthesis and study of phosphorus sulfide-based electrodes for lithium-ion and sodium-ion batteries

Yuliya Kudryashova<sup>1,2</sup>, Dmitrii Gryzlov<sup>1</sup>, Anna Kuz'mina<sup>1</sup>, Tatiana Kulova<sup>1</sup>, Alexander Skundin<sup>1</sup>

<sup>1</sup>*Frumkin Institute of Physical Chemistry and Electrochemistry of the RAS, Moscow, Russia, 119071*

<sup>2</sup>*National Research University "Moscow Power Engineering Institute" Moscow, Russia 111250*

[yulia.kudryashova@mail.ru](mailto:yulia.kudryashova@mail.ru)

The search for new functional materials for chemical power sources is an urgent task of electrochemical energy. In the present work, we have synthesized composites based on phosphorus sulfide and carbon (P<sub>x</sub>S<sub>y</sub>/C). Synthesis of P<sub>x</sub>S<sub>y</sub>/C was carried out in an atmosphere of argon at a temperature of 470 ° C for 2 hours. The stoichiometric mixtures of red phosphorus and sulfur were used as starting reagents. Two types of carbon black with different specific surface area: Ketjen Black-300 (KB-300) and Ketjen Black-600 (KB-600) were used as a carbon substrate.

For physico-chemical and electrochemical characterization of the synthesized samples scanning electron spectroscopy, Raman spectroscopy, electron dispersion analysis and cyclic voltammetry were used. As a result, the synthesized composites were found to have the composition P<sub>4</sub>S<sub>3</sub>/C. The morphology of the synthesized samples is determined by the morphology of the carbon substrate. Electrochemical tests showed that lithium and sodium are capable of being reversibly incorporated into the synthesized composites. The reversible capacity for lithium insertion at a current density of 250 mA/g was about 550 and 660 mAh/g for P<sub>4</sub>S<sub>3</sub>/KB-600 and P<sub>4</sub>S<sub>3</sub>/KB-300, respectively. Reversible capacity during sodium introducing in P<sub>4</sub>S<sub>3</sub>/C was much lower and for both composites did not exceed 300 mAh/g.

Prolonged cycling of P<sub>4</sub>S<sub>3</sub>/KB-300 at a current density of 250 mA/g showed that stable capacity can be achieved by using 1M LiPF<sub>6</sub> electrolyte in a mixture of ethylene carbonate – diethylcarbonate – dimethylcarbonate (1: 1: 1) with the addition of 1% vinylene carbonate.

*Acknowledgments:* This work was supported by the Russian Foundation for Basic Research, project nos. 19-03-00236.

## Study of the lithium insertion into germanium nanofilaments

Anna Kuz'mina<sup>1</sup>, Il'ya Gavrilin<sup>2</sup>, Yuliya Kudryashova<sup>1,3</sup>, Tatiana Kulova<sup>1</sup>, Alexander Skundin<sup>1</sup>

<sup>1</sup>Frumkin Institute of Physical Chemistry and Electrochemistry of the RAS, Moscow, Russia, 119071

<sup>2</sup>National Research University of Electronic Technology, Zelenograd, Moscow Region, 124498 Russia

<sup>3</sup>National Research University "Moscow Power Engineering Institute" Moscow, Russia 111250

[nyurka\\_92@mail.ru](mailto:nyurka_92@mail.ru)

Germanium is a promising material for the negative electrode in lithium-ion batteries. Germanium can form alloys with lithium with the general composition of up to  $\text{Li}_{4.2}\text{Ge}$  [1].

Nanostructured germanium samples prepared by electrochemical deposition were tested as the negative electrodes of lithium-ion batteries. The electrochemical deposition of germanium was carried out in a three-electrode cell. A titanium plate with the applied array of indium nanoparticles was used as the working electrode; the counter electrode was a platinum plate; the reference electrode was a saturated calomel electrode. The deposition was carried out in an electrolyte solution contained 0.05 M germanium(IV) oxide  $\text{GeO}_2$ , 0.5 M potassium sulfate  $\text{K}_2\text{SO}_4$  as the supporting salt and 0.5M succinic acid as the buffering additive. The solution pH was brought to 6.5 by adding  $\text{NH}_4\text{OH}$ . The solution temperature was kept at a level of 20 °C. The current densities were about 0.1, 0.5 and 2  $\text{mA}/\text{cm}^2$ . The electrochemical testing of electrodes with the deposited germanium layer (working electrodes) were carried out in hermetically sealed three-electrode cells of the plane-parallel design with lithium counter electrodes and lithium reference electrodes. As the electrolyte, we used 1 M  $\text{LiPF}_6$  in the mixture of ethylene carbonate-diethylcarbonate-dimethylcarbonate (1:1:1).

Studying germanium by means of SEM method has shown that the synthesized samples represent filamentary structures with the diameter from 30 to 60 nm. The increase of the current density leads to formation of germanium filaments with less diameter.

Cyclic voltammograms (CVA) of germanium electrode were recorded at different potential scan rates in the potential range from 3 to 0.01 V ( $\text{Li}^+/\text{Li}$ ). In the CVA, three clear cathodic peaks are observed, which formally correspond to the formation of lithium-germanium alloys with different composition. The anodic CVA branch represents superposition of two anodic peaks in the potential range of 0.01–0.8 V, the sharp division of which is possible only at a low potential scan rate, and also a weakly pronounced anodic peak in the potential range of 1.0–1.1 V. The reversible capacities calculated from the area under the anodic CVA branches for the potential scan rate of 0.05 mV/s were 740, 650, 1210 mA h/g for samples obtained at current densities of 0.1, 0.5 and 2.0  $\text{mA}/\text{cm}^2$  respectively. The increase of scan rate leads to slight decrease of capacity, and for germanium synthesized at current density of 2  $\text{mA}/\text{cm}^2$  reversible capacity at scan rate 20 mV/s remains about 500 mA h/g.

The aforesaid allows us to conclude that nanostructured germanium produced by electrochemical deposition from aqueous solution is a promising material for the negative electrode of lithium-ion batteries.

*Acknowledgment:* The work was carried out in accordance with the State Task for Frumkin Institute of Physical Chemistry and Electrochemistry of the RAS.

### References

1. S. Goriparti, E. Miele, F.D. Angelis, E.D. Fabrizio, R.P. Zaccaria, C. Capiglia Review on recent progress of nanostructured anode materials for Li-ion batteries. Review article. *J. Power Sources*, 2014, vol. 257, p.421.

## Nickel-manganese sulfates as electrode materials for hybrid lithium–sodium ion cell

Delyana Marinova, Rosica Kukeva, Ekaterina Zhecheva, Radostina Stoyanova

*Institute of General and Inorganic Chemistry, BAS, 1113 Sofia, Bulgaria*

[d.manasieva@gmail.com](mailto:d.manasieva@gmail.com)

Polyanionic compounds belong to the main class of electrode materials for both lithium- and sodium-ion batteries that respond, to a great extent, to the modern requirements for efficient, safe and environmental compatible storage of energy. Among polyanionic compounds, sodium transition metal sulfates are of huge interest as low-cost electrode materials offering high operating voltage for alkaline ion intercalation.

In this contribution, we provide new data on the reversible electrochemical intercalation of  $\text{Li}^+$  and  $\text{Na}^+$  ions into sodium nickel manganese sulfates  $\text{Na}_2\text{Ni}_{1-x}\text{Mn}_x(\text{SO}_4)_2$  ( $0 \leq x \leq 0.44$ ) having an unusually large super-cell structure. Sulfate salts  $\text{Na}_2\text{Ni}_{1-x}\text{Mn}_x(\text{SO}_4)_2$  were simply obtained by thermal dehydration of the respective hydrates with a blödite type of structures  $\text{Na}_2\text{Ni}_{1-x}\text{Mn}_x(\text{SO}_4)_2 \cdot 4\text{H}_2\text{O}$ . The alkaline intercalation into  $\text{Na}_2\text{Ni}_{1-x}\text{Mn}_x(\text{SO}_4)_2$  was examined in model half ion cells versus metallic lithium as an anode, as well as by using Li metal as an anode and conventional lithium electrolyte.

Based on X-ray powder diffraction, TEM, IR/Raman spectroscopy and electron paramagnetic resonance spectroscopy we demonstrate that anhydrous salt  $\text{Na}_2\text{Ni}_{1-x}\text{Mn}_x(\text{SO}_4)_2$  ( $0 \leq x \leq 0.44$ ) crystallize into a new type of structure where  $\text{Ni}_{1-x}\text{Mn}_x\text{O}_6$  octahedra are bridged into pairs by edge- and corner-sharing  $\text{SO}_4^{2-}$  groups. The replacement of smaller  $\text{Ni}^{2+}$  ions by bigger  $\text{Mn}^{2+}$  ions induces significant lattice strains, which are accommodated by increasing the distortion of metal polyhedra. As a result, the concentration range of the Mn solubility in the super-cell  $\text{Na}_2\text{Ni}_{1-x}\text{Mn}_x(\text{SO}_4)_2$  is restricted up to  $x \leq 0.44$ .

We demonstrate for the first time that  $\text{Na}_2\text{Ni}_{1-x}\text{Mn}_x(\text{SO}_4)_2$  participates in reversible intercalation/de-intercalation reactions with alkaline ions and exhibits a specific capacity above 100 mAh/g as a cathode material in lithium-ion cells. A mechanism of the electrochemical reaction is monitored by ex-situ powder X-ray diffraction. The electrochemical behaviour of  $\text{Na}_2\text{Ni}_{1-x}\text{Mn}_x(\text{SO}_4)_2$  in lithium-ion cells is compared with that for recently reported new phase  $\text{Na}_{2+\delta}\text{Mn}_{2-\delta/2}(\text{SO}_4)_3$  ( $\delta = 0.44$ ) with an alluaudite type of structure [2].

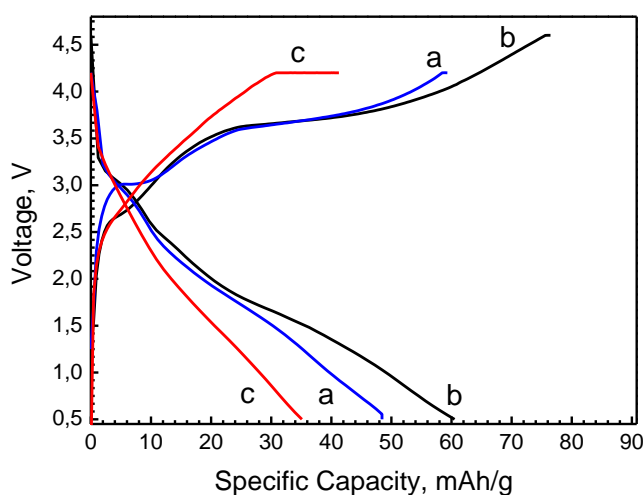

Figure. First charging curve up to 4.2 V (a) and 4.6 V (b) and corresponding discharging curves (a and b) for  $\text{Na}_2\text{Ni}_{1/2}\text{Mn}_{1/2}(\text{SO}_4)_2$  in a full-cell versus  $\text{Li}_4\text{Ti}_5\text{O}_{12}$  anode and lithium electrolyte  $\text{LiPF}_6/\text{EC}:\text{DMC}$ . The cell starts with a charge mode. The charging and discharging curves for  $\text{Na}_2\text{Ni}_{1/2}\text{Mn}_{1/2}(\text{SO}_4)_2$  in a full-cell versus  $\text{Li}_4\text{Ti}_5\text{O}_{12}$  anode and sodium electrolyte,  $\text{NaPF}_6/\text{EC}:\text{DEC}$  (c).

*Acknowledgments:* The National Science Fund of Bulgaria (Project DN09/13) is acknowledged for the financial support.

### References

1. D. Marinova, R. Kukeva, E. Zhecheva, R. Stoyanova, *Physical Chemistry Chemical Physics*, **20** (2018), 12755 (DOI:10.1039/C8CP01667D).

## Modelling of sodium manganese-based sulfates as a new class of polyanion electrode materials

Delyana Marinova, Rosica Kukeva, Ekaterina Zhecheva, Radostina Stoyanova

Institute of General and Inorganic Chemistry, BAS, 1113 Sofia, Bulgaria

[d.manasieva@gmail.com](mailto:d.manasieva@gmail.com)

Since the discovery of the first lithium-ion battery, most of the research in electrochemical energy storage has been devoted to transition metal oxides in a search of better electrode materials. The desire to keep up with the ever-growing technological needs of society and the sudden depletion of our planet's natural resources leads us to demand new electrode materials that are more efficient.

Via the last few years, the experiments in the electrochemistry of cathode materials are targeting the double sulfates of sodium and transition-metals as very perspective, cheaper and environmentally compatible. Double sulfates of sodium and transition metals, having alluaudite structure, are predicted to be a new class of high-voltage electrodes for Li/Na-ion batteries.

With this report we provide one of the first experimental evidence for electrochemical activity of sodium cobalt-manganese sulfates series,  $\text{Na}_{2+2\delta}(\text{Co}_{1-x}\text{Mn}_x)_{2-6}(\text{SO}_4)_3$  ( $0 \leq x \leq 0.54$ ) at potentials higher than 4.5 V vs  $\text{Li}/\text{Li}^+$ . The electrochemical performance of sulfate electrodes is examined in model two- and three-electrode cells. Through diffraction and spectroscopic analyzes, it is found that the high-voltage operation of the sulfate electrodes is a result of the unique properties of alluaudite salts, concerning redox properties of Co and Mn ions and stability of the structure during  $\text{Li}^+/\text{Na}^+$  exchange.

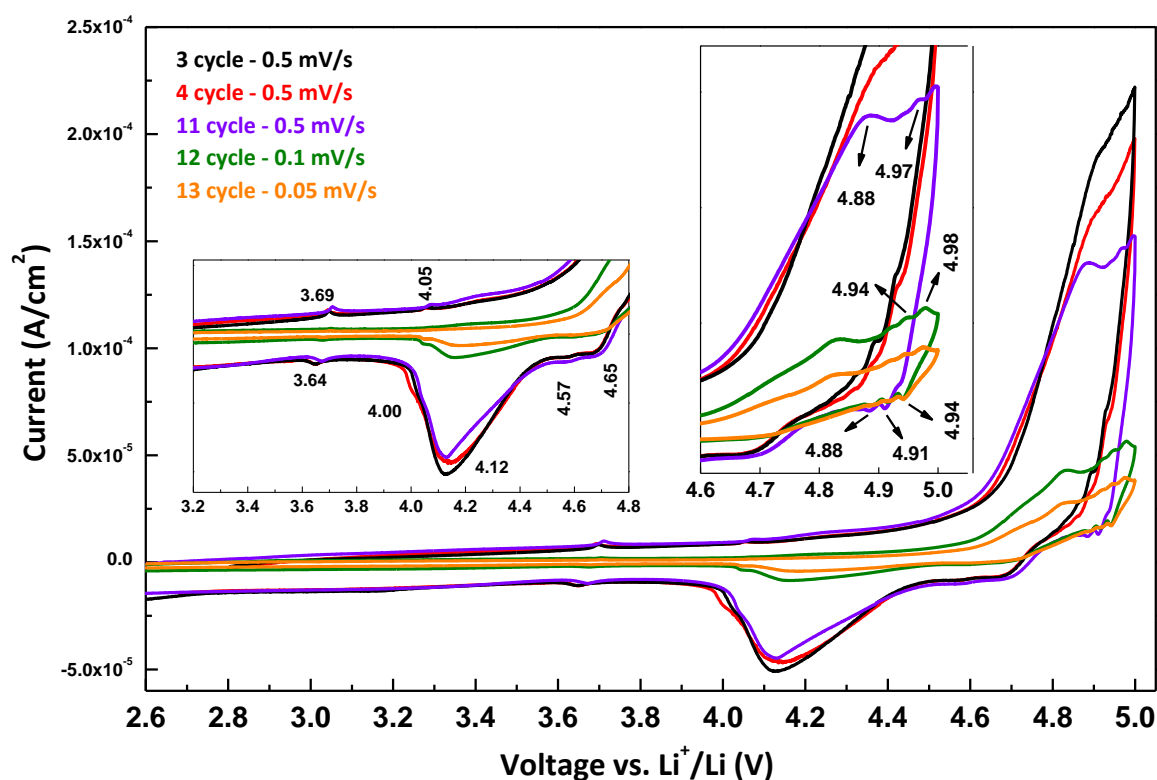

Figure: Cyclic voltammogram of  $\text{Na}_{2+2\delta}(\text{Co}_{0.63}\text{Mn}_{0.37})_{2-6}(\text{SO}_4)_3$  cells at the scan rate of 0.5, 0.1 and 0.05 mV/s

**Acknowledgments:** The National Science Fund of Bulgaria (Project DN09/13) is acknowledged for the financial support.

### References

1. D.M. Marinova, V.V. Kostov, R.P. Nikolova, R.R. Kukeva, E.N. Zhecheva, R.K. Stoyanova, *Chemical Communications*, **54** (2018) 5466 (DOI\_10.1039/C8CC01922C).

## Effect of Mg-doping on the electrochemical properties of NaMn<sub>1-x</sub>Mg<sub>x</sub>PO<sub>4</sub> phospho-olivine electrodes

Tanya Boyadzhieva, Violeta Koleva, Radostina Stoyanova

Institute of General and Inorganic Chemistry, Bulgarian Academy of Sciences, Sofia 1113, Bulgaria

[tanya\\_jb@svr.igic.bas.bg](mailto:tanya_jb@svr.igic.bas.bg)

At present, the investigations on next generation of electrode materials that should meet the increasing requirements for high power, safety, low cost and environmental compatibility are a hot research topic in the field of the alkaline-ion batteries for renewable energy storage. In this regard, phosphate-framework electrode materials offer a great promise due to the high structural and thermal stability, good cycling stability and low cost, particularly for Fe and Mn representatives. The industrial realization of LiFePO<sub>4</sub>-based battery has provoked great research interest in the other members of the olivine-type family AMPO<sub>4</sub> (A = Li, Na; M = Fe, Mn, Co, Ni). More recently, sodium analogues NaMPO<sub>4</sub> (M = Fe, Mn) phospho-olivines have attracted considerable attention as a cheaper alternative to the lithium compounds due to low cost and widespread abundance of the sodium resources with a potential for large scale applications [1-3].

In this contribution we report first data on the intercalation properties of solid solutions of NaMn<sub>1-x</sub>Mg<sub>x</sub>PO<sub>4</sub> phospho-olivines containing up to 15 at% Mg ions. To prepare NaMn<sub>1-x</sub>Mg<sub>x</sub>PO<sub>4</sub> compositions we have developed a special synthesis route based on ion-exchange reactions at 200 °C using sodium acetate and Mg-substituted dittmarite-type precursors KMn<sub>1-x</sub>Mg<sub>x</sub>PO<sub>4</sub>·H<sub>2</sub>O as structure-directing templates. By partial replacement of Mn ions with Mg ions we expect to achieve the following main effects: (i) Structural stabilization of the desodiated phase Mn<sub>1-x</sub>Mg<sub>x</sub>PO<sub>4</sub> as a result of the dilution of Jahn Teller Mn<sup>3+</sup> ions; (ii) Increased electron conductivity of the Mg-doped compositions. The latter effect has been confirmed by our measurements indicating higher electron conductivity with two orders of magnitude for NaMn<sub>1-x</sub>Mg<sub>x</sub>PO<sub>4</sub> as compared to non-substituted NaMnPO<sub>4</sub>. This benefit has a particularly favourable impact on the improved intercalation properties of NaMn<sub>1-x</sub>Mg<sub>x</sub>PO<sub>4</sub> compounds as electrodes in alkaline-ion batteries.

The electrochemical tests have been performed with composites of pristine NaMn<sub>1-x</sub>Mg<sub>x</sub>PO<sub>4</sub> compositions with carbon black Super C/65 obtained by ball milling. Both pristine and composites phospho-olivines have been characterized by XRD-powder diffraction (Rietveld analysis), IR, Raman and EPR spectroscopy and SEM and TEM analyses.

The intercalation properties of NaMn<sub>1-x</sub>Mg<sub>x</sub>PO<sub>4</sub>/C cathodes in respect to Li<sup>+</sup> and Na<sup>+</sup> ions have been examined in two-electrode cells using both lithium and sodium electrolytes (LiPF<sub>6</sub> in EC:DMC, NaPF<sub>6</sub> in EC:DMC, NaPF<sub>6</sub> in PC) and different anodes such as metal Li, Li<sub>4</sub>Ti<sub>5</sub>O<sub>12</sub> and nanotube sodium titanate. In order to gain insight on the mechanism of the intercalation reactions *ex-situ* diffraction, spectroscopic and microscopic studies have been also carried out. The results obtained show the potential of the Mg-doped NaMnPO<sub>4</sub> phospho-olivines for use as electrode materials in alkaline ion batteries.

*Acknowledgments:* The authors are grateful to the financial support from the National Science Fund of Bulgaria (Project DN09/13).

### References

1. Q. Ni, Y. Bai, F. Wu, C. Wu, *Adv. Sci.*, **4** (2017) 1600275.
2. T. Boyadzhieva, V. Koleva, E. Zhecheva, D. Nihtianova, L. Mihaylov, R. Stoyanova, *RSC Advances* **5** (2015) 87694-87705.
3. R. Stoyanova, V. Koleva, A. Stoyanova, *The Chemical Record (Review)* (2019), DOI: 10.1002/tcr.201800081.

## Mixed Fe/Mn based phospho-olivines as electrodes in hybrid metal-ion batteries

Tanya Boyadzhieva, Violeta Koleva, Radostina Stoyanova

*Institute of General and Inorganic Chemistry, Bulgarian Academy of Sciences, Sofia 1113, Bulgaria*

[tanya\\_ib@svr.igic.bas.bg](mailto:tanya_ib@svr.igic.bas.bg)

Olivine-type  $\text{LiMPO}_4$  ( $M = \text{Fe, Mn, Co, Ni}$ ) compounds, known as phospho-olivines, are the major representatives of the polyanion electrode materials of which only  $\text{LiFePO}_4$  is currently used as commercialized cathode materials in lithium-ion batteries. They are characterized by high theoretical capacity (170 mAh/g), high safety due to structure and thermal stability, and long-term durability. More recently, the current requirements for the development of cheaper "green" batteries gave a strong impetus to research on the sodium analogies of phospho-olivines,  $\text{NaMPO}_4$  ( $M = \text{Fe, Mn}$ ). Manganese-based compounds,  $\text{LiMnPO}_4$  and  $\text{NaMnPO}_4$ , display higher energy density than the respective iron compounds (the working potentials for  $\text{LiFePO}_4$  and  $\text{LiMnPO}_4$  are 4.1 and 3.4 V, respectively) and this makes them highly desirable electrode materials for high-power applications. The electrochemical performance of the Mn-based materials, however, is worse (low discharge capacity and rather poor rate capability during prolonged cycling) than that of the iron representatives mainly due to: (i) very low ion and electron conductivities that lead to sluggish kinetics of the alkaline-ion intercalation; (ii) structure instability of the charged phase  $\text{MnPO}_4$  induced by the Jahn–Teller  $\text{Mn}^{3+}$  ions. From electrochemical point of view, the solid solutions between  $\text{Li/NaFePO}_4$  and  $\text{Li/NaMnPO}_4$  are expected to combine all advantages of the single electrode materials such as higher power density typical for the manganese compounds and fast charge/discharge and structure stability typical for the iron compounds.

In this contribution our attention is focused on both lithium and sodium iron-manganese phospho-olivines, where 20 mol% of the Mn ions are substituted by Fe ions. The compositions  $\text{LiMn}_{0.8}\text{Fe}_{0.2}\text{PO}_4$  and  $\text{NaMn}_{0.8}\text{Fe}_{0.2}\text{PO}_4$  are particularly promising since the iron amount is sufficient to stabilize the charged phase  $\text{Mn}_{0.8}\text{Fe}_{0.2}\text{PO}_4$  and to improve the Li/Na diffusion kinetics without compromising energy density.

Unlike  $\text{LiFe}_x\text{Mn}_{1-x}\text{PO}_4$ , sodium analogues are metastable phases, so that original synthesis approaches are required for their preparation. Till now, there is only one report on the formation of a mixed composition  $\text{NaMn}_{0.5}\text{Fe}_{0.5}\text{PO}_4$ . Here, we present first data on the synthesis, characterization and intercalation properties of olivine-type  $\text{NaMn}_{0.8}\text{Fe}_{0.2}\text{PO}_4$ .

Both  $\text{NaMn}_{0.8}\text{Fe}_{0.2}\text{PO}_4$  and  $\text{LiMn}_{0.8}\text{Fe}_{0.2}\text{PO}_4$  are prepared by ion-exchange reactions at low temperature (200–325°C) using one and the same dittmarite-type precursor  $\text{NH}_4\text{Mn}_{0.8}\text{Fe}_{0.2}\text{PO}_4$  acting as a structure template. Macro-structure and local structure of the cations and phosphate anions in both precursor and target phospho-olivines have been studied by Rietveld refinement of X-ray powder diffraction data, EPR and IR spectroscopy. The results obtained give evidence that the homogeneous Mn/Fe distribution in the metal-phosphate layers of the dittmarite structure is transmitted to the target olivine structure without any reorganization, thus providing phospho-olivines largely free of anti-site defects. Despite the use of one and the same precursor the morphology of the lithium and sodium phases differs remarkably as shown by SEM images. Whereas  $\text{LiMn}_{0.8}\text{Fe}_{0.2}\text{PO}_4$  inherits plate-like morphology typical for  $\text{NH}_4\text{Mn}_{0.8}\text{Fe}_{0.2}\text{PO}_4$  precursor,  $\text{NaMn}_{0.8}\text{Fe}_{0.2}\text{PO}_4$  displays rod-like morphology which could be related to the large interface strains at the grain boundary precursor/sodium olivine phase because of the hindered sodium ion diffusion.

The electrochemical properties of  $\text{NaMn}_{0.8}\text{Fe}_{0.2}\text{PO}_4$  and  $\text{LiMn}_{0.8}\text{Fe}_{0.2}\text{PO}_4$  are tested in model two electrode cells versus lithium anode and  $\text{LiPF}_6$ -based electrolyte. It is established that  $\text{NaMn}_{0.8}\text{Fe}_{0.2}\text{PO}_4$  is able to intercalate reversibly about 0.55 mol alkaline ions which proceeds through not well defined voltage plateaus. In contrast, Li intercalation in  $\text{LiMn}_{0.8}\text{Fe}_{0.2}\text{PO}_4$  takes place via two plateaus due to  $\text{Mn}^{3+}/\text{Mn}^{2+}$  and  $\text{Fe}^{3+}/\text{Fe}^{2+}$  couples with a good reversible capacity of about 140 mAh/g. These data determine the potential of these mixed phospho-olivines for application as electrode materials for lithium and sodium ion batteries.

*Acknowledgments:* The authors are grateful to the financial support from the National Science Fund of Bulgaria (Project DN09/13).

## Gas diffusion electrodes (GDEs) for MH-Air battery systems

Borislav Abrashev, George Pchelarov, Konstantin Petrov

*Institute of Electrochemistry and Energy Systems, Bulgarian Academy of Sciences, G. Bonchev St.,  
Building 10, 1113 Sofia, Bulgaria*  
[babrashev@iees.bas.bg](mailto:babrashev@iees.bas.bg)

Metal hydride-air batteries are a promising candidate for energy storage devices. A key issue in attaining that goal is the usage of bi-functional oxygen electrode (BOE)[1]. The GDEs with two different active layers (AL) were tested and investigated. The gas diffusion layer (GDL) is produced from teflonized Vulcan XC-72. In this research the electrocatalytic properties of  $\text{Co}_3\text{O}_4$  and  $\gamma$  -  $\text{MnO}_2$  were investigated. The current densities obtained for the oxygen reduction reaction (ORR) were in the range  $5 \text{ mA/cm}^2$  and up to  $30 \text{ mA/cm}^2$ . The Volt-Ampere characteristics and the charge/discharge tests show that the most suitable catalyst with regard to the stability of the GDEs is  $\gamma$  -  $\text{MnO}_2$ . The GDEs with the above composition reach more than 100 cycles without a decrease in performance.

### References

- [1] B. Abrashev, **D. Uzun**, H. Hristov, D. Nicheva, K. Petrov, Design of an electrochemical cell for Bi-functional Oxygen Electrode (BOE) studies, *Advances in Natural Science: Theory & Applications*, Volume 4 No. 2, 65-68, **2015**

## Reduced graphene oxide/ $\alpha$ -Fe<sub>2</sub>O<sub>3</sub> fibres as active material for supercapacitor application

Gabrijela Radić<sup>1</sup>, Ivan Šajnović<sup>1</sup>, Marijana Kraljić Roković<sup>1</sup>, Željka Petrović<sup>2</sup>

<sup>1</sup>University of Zagreb, Faculty of Chemical Engineering and Technology, Department of Electrochemistry, Marulićev trg 19, 10000 Zagreb, Croatia

<sup>2</sup>Ruđer Bošković Institute, Division of Materials Chemistry, Bijenička c. 54, 10002 Zagreb, Croatia  
[mkralj@fkit.hr](mailto:mkralj@fkit.hr); [zpetrov@irb.hr](mailto:zpetrov@irb.hr)

The supercapacitors are an attractive alternative to batteries because they can provide higher power density and longer cycle life but suffer from lower energy density. For successful application of supercapacitors in hybrid electric vehicles, both high power and energy densities are required.<sup>1,2</sup> Therefore, much effort has been made to achieve these demands. One approach includes a development of new active materials based on the different material combinations, morphology and particle size.<sup>3</sup> A promising strategy would be a combination of a capacitive material (carbon nanotubes, graphene) with an earth-abundant, nontoxic and low-cost metal oxide (RuO<sub>2</sub>, MnO<sub>2</sub>, IrO<sub>2</sub>, MoO<sub>2</sub>, V<sub>2</sub>O<sub>5</sub>, SnO<sub>2</sub>, Fe<sub>2</sub>O<sub>3</sub>, or Fe<sub>3</sub>O<sub>4</sub>). Such a combination provides good conductivity which is attributed to the carbon structures and high energy densities which are attributed to the pseudocapacitive effects of metal oxides.

In this work the composite hydrogel, composed of reduced graphene oxide and hematite fibres (rGO/hematite), was successfully prepared by the hydrothermal procedure starting from GO and hematite nanofibres. Morphological and structural characteristics of the composite hydrogel were investigated by using SEM and XRD techniques. According to the results, hematite fibres are distributed between rGO sheets increasing the inter-sheet space and decreasing the rGO restacking. The composite was tested as an active material in supercapacitor and therefore, two different symmetric supercapacitors were prepared, one containing pure rGO and the other composite hydrogel. The electrochemical charge storage characteristics of prepared supercapacitors were investigated in 0.5 mol dm<sup>-3</sup> Na<sub>2</sub>SO<sub>4</sub> by cyclic voltammetry, galvanostatic charge/discharge, and electrochemical impedance spectroscopy. The obtained results confirmed a positive effect of the hematite addition on electrochemical properties of the new composite material: (i) specific capacitance values of supercapacitor were increased from 17.5 F g<sup>-1</sup> (bare rGO) to 26.2 F g<sup>-1</sup> (composite rGO/hematite) and (ii) restructuring of the active material, that takes place during charging/discharging, is minimized.

*Acknowledgment:* This work was financially supported by the Croatian Science Foundation (HRZZ) within the projects: 1D-DopedFeOX (IP-2016-06-8254) and ESUP-CAP (IP-11-2013-8825).

### References

1. F. Zhang, T. Zhang, X. Yang, L. Zhang, K. Leng, Y. Huang, Y. Chen, *Energy and Environmental Science* **6** (2013) 1623
2. G. Yu, L. M. Vosgueritchian, H. Wang, X. Xie, J. R. McDonough, X. Cui, Y. Cui, Z. Bao, *Nano Letters* **11** (2011) 2905
3. J. Eskusson, P. Rauwel, J. Nerut, A. Jänes, *Journal of The Electrochemical Society* **163** (2016) A2768

## PEDOT-based composites prepared by one-step electrochemical method for supercapacitors applications

Gabrijela Ljubek, Nikola Vugrinec<sup>1</sup>, Marijana Kraljić Roković<sup>1</sup>

University of Zagreb, Faculty of Mining, Geology and Petroleum Engineering, Zagreb, Croatia

<sup>1</sup>University of Zagreb, Faculty of Chemical Engineering and Technology, Zagreb, Croatia

[gslavic@rqn.hr](mailto:gslavic@rqn.hr)

Poly(3,4-ethylenedioxythiophene) (PEDOT) is a conductive polymer which already has a brief history of being used as an active material in supercapacitors. It is mostly due its low-cost, flexibility and good electrical conductivity, which results in fast electrochemical reactions. However, the major drawback is low cycling stability due to its poor mechanical strength [1]. Another disadvantage is its limited capacitance due to the low utilisation of the material. The activity of PEDOT is decreased by limited ion transport in the bulk of material [2]. To solve this problems, composites of PEDOT and graphene or its derivatives has gained a lot of scientific ground during the last few years, especially in the field of supercapacitors.

In this work, a facile and one-step electrochemical method is introduced for incorporating graphene oxide (GO) into PEDOT layer in the presents of poly(4-styrene sulfonate) (PSS) as supporting electrolyte. The presence of PSS can enhance not only the polymerization step but also the morphology and microstructure of PEDOT layer. The incorporation of GO could significantly increase cycling stability as well as porosity of the material. Morphological and structural properties of the obtained layers were characterized by means of scanning electron microscopy and UV/Vis spectroscopy. By using cyclic voltammetry and electrochemical impedance spectroscopy (EIS) methods it was shown that all prepared materials exhibited good capacitive properties in  $0.1 \text{ mol dm}^{-3}$  KCl solution. The prepared materials were used to assemble symmetric supercapacitors that were tested by cyclic voltammetry and EIS methods. The stability of the supercapacitors was determined by charging/discharging at constant current during 1000 cycles.

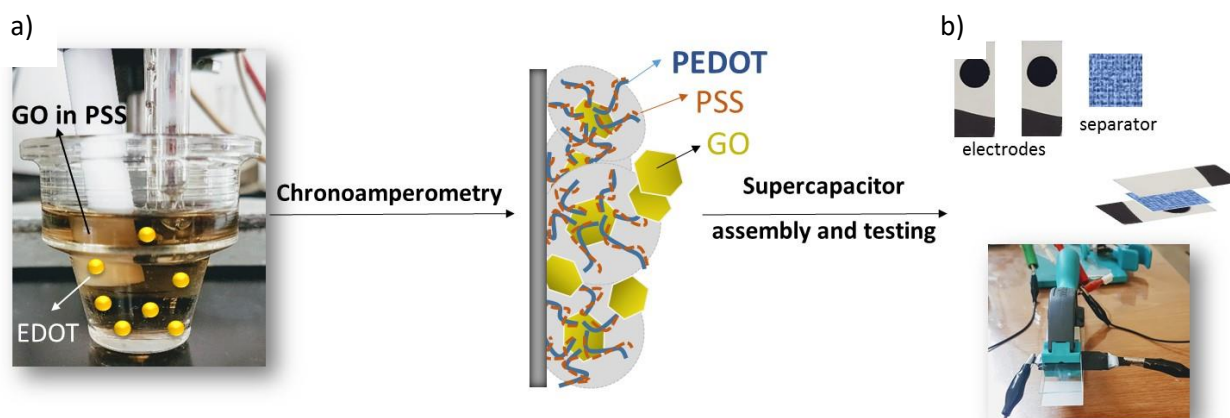

Fig.1 a) Electrochemical polymerization of PEDOT/GO layer at constant potential in an aqueous solution containing  $0.02 \text{ mol dm}^{-3}$  EDOT monomer and  $0.01 \text{ mol dm}^{-3}$  PSS with addition of  $2 \text{ mg ml}^{-1}$  GO. b) Assembly and testing of the supercapacitors with PEDOT/GO electrodes as active material.

### References

1. M. Wilamowska, M. Kujawa, M. Michalska, L. Lipinska, A. Lisowska-Oleksiak, *Synthetic Metals* **220**(2016) 334-346 ([https://dx.doi.org/XX.YYYY/doi\\_number](https://dx.doi.org/XX.YYYY/doi_number))
2. A. Österholma, T. Lindfors, J. Kauppilab, P. Damlinb, C. Kvarnströmb, *Electrochimica Acta* **83** (2012) 463-470 (<https://doi.org/10.1016/j.electacta.2012.07.121>)

## Electrochemical performance of symmetric supercapacitors based on carbon biomaterials in different electrolytes

B. Karamanova<sup>1</sup>, Sv. Veleva<sup>1</sup>, A. Stoyanova<sup>1</sup>, R. Stoyanova<sup>2</sup>

<sup>1</sup> Institute of Electrochemistry and Energy Systems, Bulgarian Academy of Sciences, Sofia, 1113, Bulgaria

<sup>2</sup> Institute of General and Inorganic Chemistry, Bulgarian Academy of Sciences, Sofia, 1113, Bulgaria  
[boriana.karamanova@iees.bas.bg](mailto:boriana.karamanova@iees.bas.bg)

The supercapacitors are known to be promising energy storage devices for applications requiring high power and long cycle life. There are two basic and interlinked approaches to improving their capacity and stability, focusing on the appropriate choice of electrode material on the one hand and the electrolyte on the other. The present study examines the relationship between the texture and the surface chemistry of two activated carbons, the electrolyte type and the electrochemical properties of symmetric supercapacitors.

The used carbons are commercial materials, produced from “Kuraray Europe” GmbH and obtained by pyrolysis of coconuts by green technology. They are physicochemically characterized by XPS spectroscopy, SEM and BET analyses. The surface functional groups and pore size distribution are determined by Böhm titration method and Barrett-Joyner-Halenda analysis, respectively. The supercapacitor performances are tested by charge/discharge galvanostatic experiments in aqueous (KOH, LiOH, NaOH) and organic electrolytes (LiBF<sub>4</sub>, NaBF<sub>4</sub>, LiPF<sub>6</sub> with different solvents). To go inside into surface and bulk electrode changes during electrode cycling, the *ex-situ* XPS and SEM/EDS experiments are undertaken.

The SC cells demonstrate high discharge and stable capacitance as well as high effectiveness of charge-discharge process in alkaline electrolytes. It is found that activated carbon having lower content of acidic groups and higher specific surface area displays best performances in 6 M KOH. These results confirm that the electrolyte conductivity and the adsorption of the electrolyte ions into electrode materials contribute greatly on charge storage behaviour of the electrodes in these systems.

In organic electrolytes, the investigated ACs show stable behaviour, but a lower capacity than in alkaline electrolytes. The reasons for this result may be related to their morphology and the different (more complex) processes occurring in these mediums. The development of composite electrodes between AC and transition metal oxides/hydroxides, which show complex morphological architectures and provide a synergistic effect between the components, is a perspective of improving their electrochemical properties.

*Acknowledgement:* The financial support of the BNSF under project № КП-06-ОПР 04/5 is gratefully acknowledged. The parts of the experiments were performed with equipment included in the National Infrastructure NI SEVE supported by the Ministry of Education and Science under grant agreement № DO1-160/28.08.18.

## Microwave-assisted polyol synthesis of Pt based catalysts: enhanced methanol activity and CO tolerance

Sanja Stevanović, Vladislava M. Jovanović

*ICTM, Department of Electrochemistry, University of Belgrade, Njegoševa 12, Belgrade*  
[sanjat@tmf.bg.ac.rs](mailto:sanjat@tmf.bg.ac.rs)

Direct methanol fuel cells (DMFCs) are very promising power sources for stationary and portable electric devices due to its high efficiency and low emissions of pollutants, low operating temperature, high energy density, nontoxic and environmentally friendly characteristics. However, their wider commercial use is limited by factors such as: high costs of precious metal in electrocatalyst (for example, Pt) and poor operation durability *i.e.* rapid anode activity degradation. In order to reduce the catalyst cost and promote their performance, many strategies have been launched, and over the past few years the most were based on the synthesis of platinum catalysts in which platinum is alloyed with less expensive metals such as Ru [1], Sn [2], Ni [3], Zn [4] *etc.*

In this work, the activity for methanol electrooxidation of PtSn, PtZn and PtSnZn catalysts in acidic medium has been introduced. Stable Pt, PtSn, PtZn and PtSnZn nanoparticles have been successfully synthesized by microwave assisted polyol method. The results are always benchmarked to Pt/C prepared following the same treatment.

The effects of composition, alloying degree, particle size and morphology on electrocatalytic activity were examined through the CO stripping voltammetry and methanol electrooxidation reaction. Detailed comprehensive study of CO and methanol oxidation was investigated at an *as prepared* and electrochemically treated catalysts.

The results obtained indicate enhanced catalytic activities for methanol oxidation reaction and improved resistance ability to CO inhibition, after addition of Sn or Zn to Pt catalyst.

*Acknowledgements:* This work was financially supported by the Ministry of Education and Science, Republic of Serbia, Contract No. H-172060.

### References

1. Y. Hu, A. Zhu, Q. Zhang, Q. Liu, „Preparation of PtRu/C core–shell catalyst with polyol method for alcohol oxidation”, *International Journal of Hydrogen Energy*, 41 (26), (2016), pp 11359–11368.
2. H. Su, Tie-Hong Chen, „Preparation of PtSn<sub>2</sub>–SnO<sub>2</sub>/C nanocatalyst and its high performance for methanol electro-oxidation” *Chinese Chemical Letters*, 27(7), (2016), pp 1083–1086.
3. N.R. Mathe, M.R. Scriba, N.J. Coville, „Methanol oxidation reaction activity of microwave-irradiated and heat-treated Pt/Co and Pt/Ni nano-electrocatalysts” *Int J Hydrogen Energy*, 39, (2014), pp. 18871–18881.
4. Chien-Te Hsieh, Wei-Min Hung, Wei-Yu Chen, Jia-Yi Lin, „Microwave-assisted polyol synthesis of PteZn electrocatalysts on carbon nanotube electrodes for methanol oxidation”, *Int J Hydrogen Energy*, 36 (4), (2011), pp 2765-2772.

## Ni-Sn coating as electrocatalyst for ethanol oxidation in alkaline solution

Jelena Lović, Vladimir Jović<sup>1</sup>

ICTM, Department of Electrochemistry, University of Belgrade, Njegoševa 12, 11000, Belgrade, Serbia

<sup>1</sup> Institute for Multidisciplinary Research, University of Belgrade, Kneza Višeslava 1, 11030, Belgrade, Serbia

[jelena.lovic@ihm.bq.ac.rs](mailto:jelena.lovic@ihm.bq.ac.rs)

Ni-Sn alloy coating was deposited galvanostatically at  $j = -100 \text{ mA cm}^{-2}$  from the bath containing  $0.1 \text{ M Sn}^{2+}$  and  $0.1 \text{ M Ni}^{2+}$  ions in the pyrophosphate-glycine solution [1]. The coating sample was investigated for ethanol oxidation reaction (EOR) in alkaline solution using cyclic voltammetry (Fig. 1). Chronoamperometric measurements were used to determine the electrocatalyst stability. The presence of Sn can contribute to the oxidation of the EOR products that poisons the Ni surface sites. Also the presence of Sn atoms within the Ni structure, modifies the electronic density of states of Ni, thus preventing strong binding of poisoning species. This work represents a recommendation in developing cost-effective electrocatalyst with high activity and stability for EOR in DEFCs.

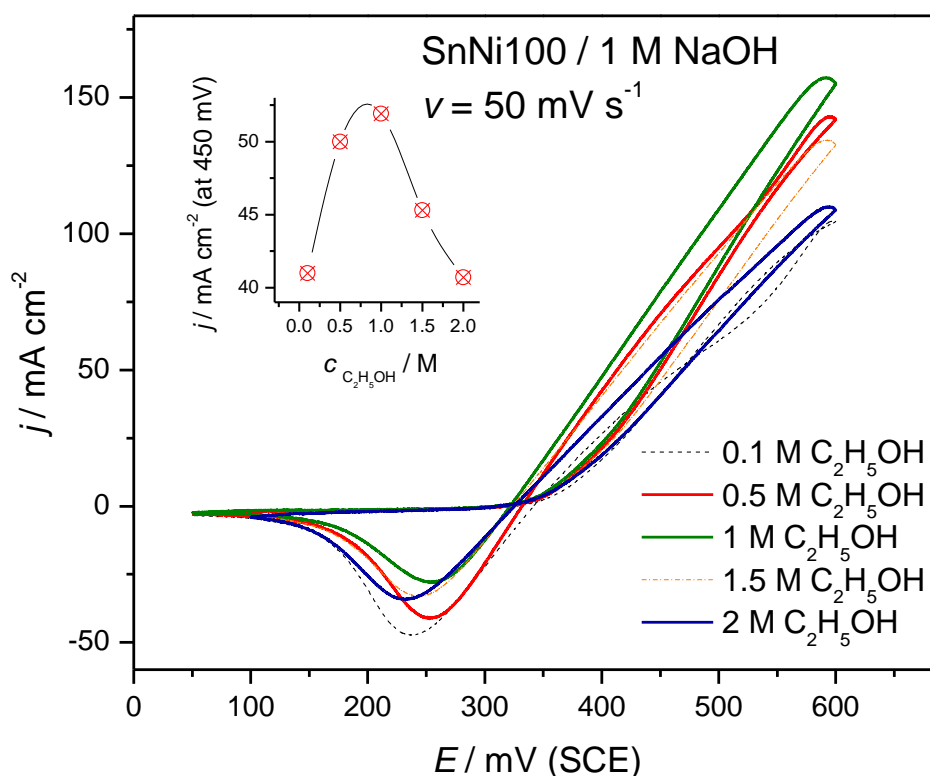

Fig. 1. CVs of Ni-Sn alloy coating in 1 M NaOH recorded for different concentrations of ethanol. Scan rate  $50 \text{ mV s}^{-1}$

This work was financially supported by the Ministry of Education, Science and Technological Development of the Republic of Serbia (Project No.172060)

### References

1. V.D. Jović, U. Lačnjevac, B.M. Jović, Lj. Karanović, N.V. Krstajić, *Int. J. Hydrogen Energ.* **37** (2012) 17882-17891 (<http://dx.doi.org/10.1016/j.ijhydene.2012.09.110>)

# **Materials and Electrochemical Processing & Electrochemical Engineering**

## Electrochemical performances of rare earth Co-based mixed oxides and their application as supercapacitors and fuel cells

Sanja Eraković<sup>1</sup>, Miroslav Pavlović<sup>1</sup>, Srećko Stopić<sup>2</sup>, Miodrag Mitrić<sup>3</sup>, Miroslava Varničić<sup>1</sup>,  
Jasmina Stevanović<sup>1,4</sup>, Vladimir Panić<sup>1,4,5</sup>, Bernd Friedrich<sup>2</sup>

<sup>1</sup>Institute of Chemistry, Technology and Metallurgy, Department of Electrochemistry,  
University of Belgrade, Serbia

<sup>2</sup>Process Metallurgy and Metal Recycling, RWTH Aachen University, Aachen, Germany

<sup>3</sup>Vinča Institute of Nuclear Sciences, University of Belgrade, Belgrade, Serbia

<sup>4</sup>Centre of Excellence in Environmental Chemistry and Engineering-ICTM, University of Belgrade, Serbia

<sup>5</sup>State University of Novi Pazar, Department of Chemical-Technological Sciences, Novi Pazar, Serbia  
[sanja@ihtm.bg.ac.rs](mailto:sanja@ihtm.bg.ac.rs)

Perovskite have emerged as promising materials in newly invented energy storage and conversion devices due to their exceptional thermal stability, electronic structure, ionic conductivity, electron mobility, and redox behaviour [1]. Among perovskite that are suitable as catalyst for electrode in supercapacitors and solid oxide fuel cells, lanthanum strontium cobalt oxides have shown promising catalytic activity and relatively high stability [1]. Also, Co-based lanthanum manganite (LMCO) has been used as cathode material with a high electro-chemical catalytic activity for oxygen reduction[2]. Ultrasonic spray pyrolysis (USP) was used to successfully synthesize spherical sub- $\mu\text{m}$ -sized of  $\text{La}_{0.6}\text{Sr}_{0.4}\text{CoO}_3$  (LSCO) and Mn and Sr-doped  $\text{LaCoO}_3$  powders. LSCO should be of wider voltage window than carbonaceous materials, with the possibility to adopt the pseudocapacitive oxide, such as  $\text{RuO}_2$ , not only by simple surface adsorption, but over full or partial incorporation into the oxide structure. Hence, this work aims to investigate supercapacitive potentials of pure LSCO prepared by single step USP and LSCO doped with  $\text{RuO}_2$ . The catalytic activity of Sr and Mn cation substitution in lanthanum cobalt oxide was also investigated.

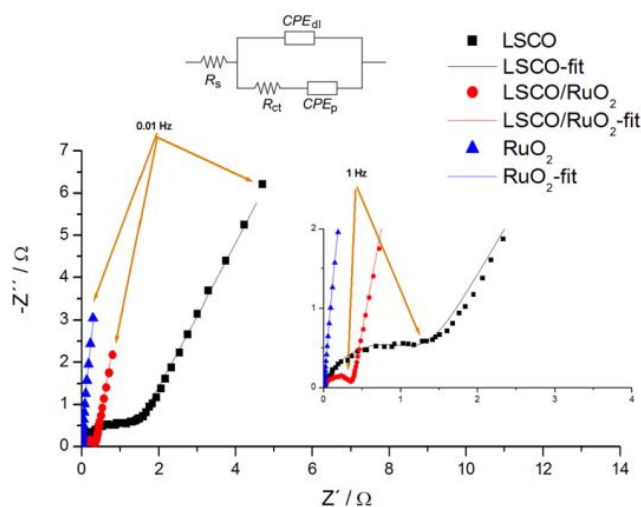

Figure 1. Nyquist plots of LSCO, LSCO/ $\text{RuO}_2$  and  $\text{RuO}_2$  in 0.10 M KOH at open circuit potential.

Electrochemical behaviour was investigated by EIS, CV and LSV techniques. The EIS and CV analyses showed that  $\text{RuO}_2$  catalyzes the redox transition of Co species, with simultaneous proportional increase in pseudocapacitive abilities of  $\text{RuO}_2$  itself while being hosted by LSCO. The investigated LMCO electrodes by CV and LSV techniques showed excellent catalytic activity for oxygen reduction. Our work indicated that these perovskite shows potential applications in the field of pseudocapacitance electrode materials and is worthy of further investigation.

### References

1. H. Zhu, P. Zhang, S. Dai, ACS Catal. 5 (2015) 6370–6385. doi:10.1021/acscatal.5b01667.
2. J. Lü, Y. Zhang, Z. Lü, X. Huang, Z. Wang, X. Zhu, et al., RSC Adv. 5 (2015) 5858–5862. doi:10.1039/C4RA13583K

## Electrodeposition of NiCo alloy powders with coral-like structure

Vesna Maksimović<sup>1</sup>, Milovan Stoilković<sup>1</sup>, Nebojša Nikolić<sup>2</sup>

<sup>1</sup>Vinča, Institute of Nuclear Sciences-Department of Materials Science, University of Belgrade, Serbia,

<sup>2</sup>ICTM-Department of Electrochemistry, University of Belgrade, Njegoševa 12, 11000 Belgrade, Serbia  
[vesnam@vinca.rs](mailto:vesnam@vinca.rs)

Electrochemical deposition processes are a valuable way to obtain open porous structures with an extremely high surface area. This type of structure is formed by electrodeposition processes where, parallel to metal deposition, a hydrogen evolution reaction occurs [1]. Additionally, it is well-known that the deposition of powders, as well as compact metal of the transition metals (such as Fe, Ni and Co) and their alloys, is accompanied by the simultaneous evolution of hydrogen from the very beginning of metal deposition.

This paper is designed to use the electrodeposition method to find appropriate conditions to deposit NiCo alloy powders with dominant open porous structure with extremely high surface area. The current density was a variable factor.

The NiCo alloy powder samples were electrodeposited at room temperature in a cylindrical glass cell with a glassy carbon rod as working electrode. Electrodeposition of the powders was performed with a constant current regime at a current density of  $j = 100, 300$  and  $500 \text{ mA cm}^{-2}$  using appropriate power supply. The powders were deposited from the electrolyte containing  $1 \text{ M (NH}_4)_2\text{SO}_4$ ,  $0.7 \text{ M NH}_4\text{OH}$  plus nickel ( $\text{NiSO}_4$ ) and cobalt ( $\text{CoSO}_4$ ) salts with  $\text{Ni}^{2+}/\text{Co}^{2+}$  ions ratio of 1.5 and pH value of electrolytes were 9.57. The morphology, phase structure and chemical composition of these powders were investigated using SEM, XRD, EDS and AES analysis. In all samples were detected dominant presents of a cauliflower-like agglomerates with individual holes formed from the detached hydrogen bubbles, but the surface morphology was found to depend on the current density during the electrodeposition process. Analysis of the agglomerates at the high magnification deposited at  $j = 100$  (Fig.1a), and  $300$  (Fig.1b)  $\text{mA cm}^{-2}$  indicates that those are constructed from coral-like particles. The main characteristic of such coral-like particles is open porous structure with regular and irregular forms due to small detached hydrogen bubbles (less than  $500\text{nm}$ ). In these cases dendritic growth is completely inhibited as a result of enhanced stirring the electrolyte in the near-electrode layer. On the other hand, agglomerate deposited at  $j = 500 \text{ mA cm}^{-2}$  are covered with fern-like dendrites. It is noteworthy to point out that those coral-like particles with open porous structure distinguished in samples of NiCo powders obtained at current densities of  $100$  and  $300 \text{ mA cm}^{-2}$ , but it could not be seen in the powder deposited at the highest current density of  $j = 500 \text{ mA cm}^{-2}$ .

The powders have a single phase face-centered cubic (fcc) structure and composition of the powders is independent of the current density.

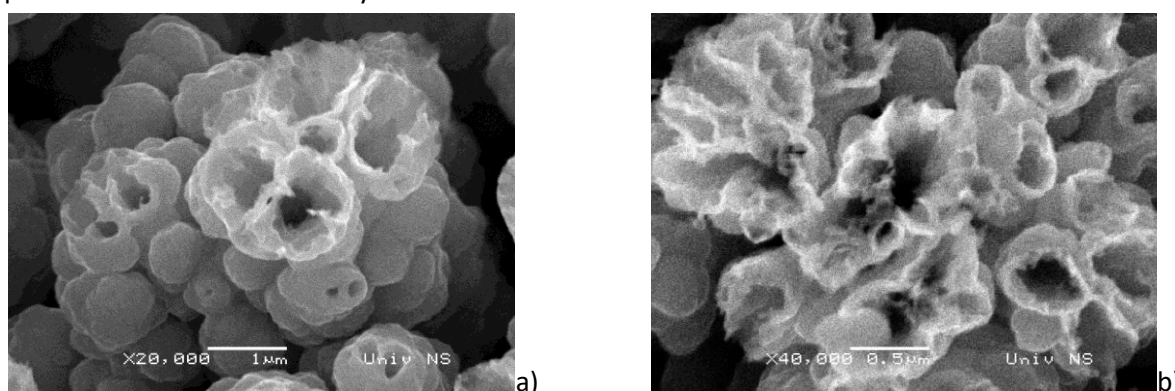

Figure 1. Morphologies of NiCo powder particles obtained at a current density of a)  $j = 100 \text{ mA cm}^{-2}$  and b)  $j = 300 \text{ mA cm}^{-2}$  with the  $\text{Ni}^{2+}/\text{Co}^{2+}$  ions ratio of 1.5, coral-like open porous structure.

### References

1. K. I. Popov, S. S. Djokić, N. D. Nikolić, V. D. Jović, Morphology of Electrochemically and Chemically Deposited Metals. Springer, New York, (2016).

## Preparation of Pt-IrO<sub>2</sub>/TiO<sub>2</sub> bi-functional catalysts

Nina Dimitrova<sup>1</sup>, J. Georgieva<sup>1</sup>, S. Sotiropoulos<sup>2</sup>, Tz. Boiadjieva-Scherzer<sup>3</sup>

<sup>1</sup>*Institute of Physical Chemistry, Bulgarian Academy of Sciences, Sofia 1113, Bulgaria*

<sup>2</sup>*Department of Chemistry, Aristotle University of Thessaloniki, Thessaloniki 54124, Greece*

<sup>3</sup>*CEST Kompetenzzentrum für elektrochemische Oberflächentechnologie GmbH, Wiener Neustadt*

A unitized regenerative fuel cell (URFC) is an electrochemical energy conversion and storage device using hydrogen as an energy carrier. It works both as H<sub>2</sub>/O<sub>2</sub> fuel cell and as water electrolyser in a single system. It is well known that the oxygen evolution (OER) and oxygen reduction (ORR) reactions, are the slowest steps in several electrochemical processes such as water electrolysis and energy generation. Both systems may alternatively operate in the same device based on a proton-exchange membrane (PEM). Therefore, its high-efficiency depends on the type of electrocatalysts. As a consequence, a broad research is focused on developing a new design for the oxygen electrode in URFCs.

Bifunctional Pt-IrO<sub>2</sub>/TiO<sub>2</sub> catalyst for unitized regenerative fuel cell (URFC) has been prepared by photodeposition of Pt and IrO<sub>2</sub> on TiO<sub>2</sub> support. The resulting Pt-IrO<sub>2</sub>/TiO<sub>2</sub> composites have been characterized by transmission electron microscopy (TEM), energy-dispersive spectroscopy (EDS) and X-ray photoelectron spectroscopy (XPS). Electrochemical characterization by CV and LSV in aqueous 0.1 M HClO<sub>4</sub> reveals that PtIrO<sub>2</sub> catalyst exhibits electrocatalytic properties for ORR and OER showing up a possible use in URFCs.

*Acknowledgments:* Financial support of CEST, Austria in the frame of the COMET program is gratefully acknowledged.

## Catalysis at nano level: Promoting Pt nanoparticle activity by Au decoration

Mila N. Krstajić Pajić, Sanja I. Stevanović<sup>1</sup>, Vuk V. Radmilović, Piotr Zabinski<sup>2</sup>, Nevenka R. Elezović<sup>3</sup>,  
Velimir R. Radmilović<sup>4</sup>, Snežana Lj. Gojković, Vladislava M. Jovanović<sup>1</sup>

Faculty of Technology and Metallurgy, University of Belgrade, Karnegijeva 4, Belgrade, Serbia

<sup>1</sup>Department of Electrochemistry, ICTM, University of Belgrade, Njegoševa 12, Belgrade, Serbia

<sup>2</sup>AGH University of Science and Technology, Faculty of Non-Ferrous Metals, Krakow, Poland

<sup>3</sup>Institute for Multidisciplinary Research, University of Belgrade, Kneza Višeslava 1, Belgrade, Serbia

<sup>4</sup>Serbian Academy of Sciences and Arts, Knez Mihailova 35, Belgrade, Serbia

[vlad@tmf.bg.ac.rs](mailto:vlad@tmf.bg.ac.rs)

Formic acid is one of the most promising small organic molecules that can be used as fuel in polymer electrolyte fuel cells. These systems are recognized as high-efficiency energy conversion devices which could offer energy generated from electrochemical processes. At carbon supported platinum nanoparticles as state of the art anodic catalysts formic acid oxidation reaction (FAOR) proceeds through a dual path mechanism that includes the formation of CO in the indirect reaction pathway. Since CO is a catalytic poison, the best way to address this problem is to synthesize catalysts that would either provide prompt CO oxidation and removal, or favour the direct reaction pathway to completely avoid CO formation and electrode poisoning. PtAu systems are considered as efficient catalysts for FAOR due to the ensemble effect of Au on Pt, however the optimal ratio of these two elements is still quite vague. Given the experience with water in oil microemulsion synthesis for preparation of shape controlled Pt nanoparticles,<sup>1</sup> bimetallic PtAu/C nanocatalysts were synthesized by the same procedure, following a simultaneous precursor reduction methodology.<sup>2</sup> The amount of the capping agent used, was varied in order to cause formation of nanoparticles with different shape (cubic or tetrahedron like). Addition of a very low, but very finely dispersed amount of Au significantly increases the catalytic activity, and also affects kinetic of the particle growth, influencing the particle shape. Ordered structure of these particles contributes to their stability as well. These results were obtained by Electrochemical and High Resolution Transmission Electron Microscopy characterization (HRTEM) with Energy Dispersive X-ray Spectroscopy (EDXS), along with X-Ray Diffraction and (XRD) and X-Ray Photoelectron Spectroscopy (XPS).

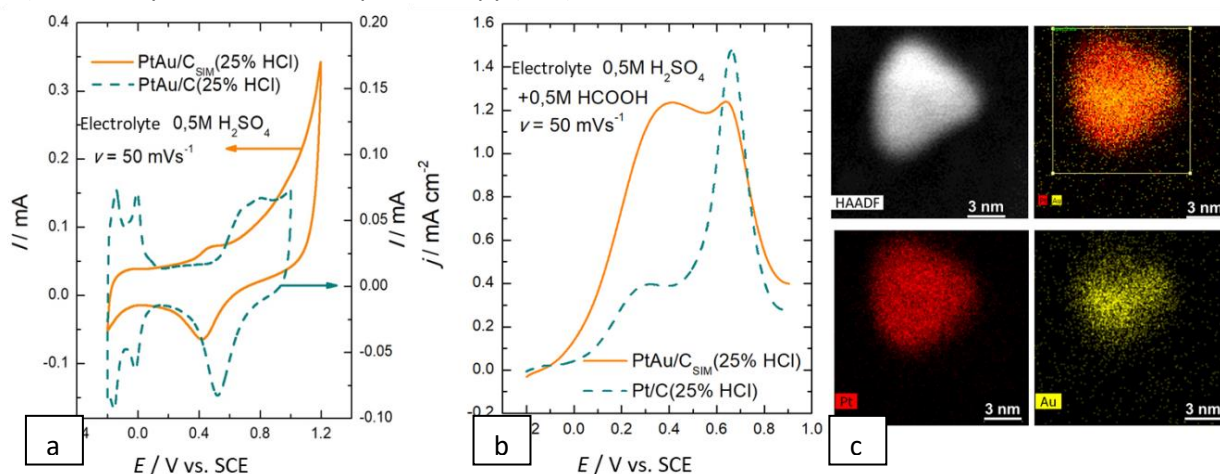

Fig 1. a) CVs recorded on Pt nanocubic and PtAu nanotetrahedron shaped catalysts in supporting electrolyte b) FAOR potentiodynamic curves in anodic direction recorded on Pt nanocubes and PtAu nanotetrahedrons, c) HAADF TEM image of PtAu nanoparticle with corresponding EDXS maps

**Acknowledgements:** This work was supported by the Ministry of Education, Science and Technological Development of the Republic of Serbia, contract no. OI 172060, and COST Action MP 1407.

### References

1. M.N. Krstajić Pajić et al, *Applied Catalysis B: Environmental* **196** (2016) 174-184
2. M.N. Krstajić Pajić et al, *Applied Catalysis B: Environmental* **243** (2019) 585-593

## Surface modification of titanium implants by adherent hydroxyapatite/titanium oxide composite coatings using novel *in-situ* synthesis

Marijana Pantović Pavlović<sup>1</sup>, Sanja Eraković<sup>1</sup>, Miroslav Pavlović<sup>1</sup>, Ljiljana Veselinović<sup>2</sup>, Jasmina Stevanović<sup>1,4</sup>, Vladimir Panić<sup>1,3,4</sup>, Nenad Ignjatović<sup>5</sup>

<sup>1</sup>*Institute of Chemistry, Technology and Metallurgy, Department of Electrochemistry, University of Belgrade, Belgrade, Serbia*

<sup>2</sup>*Vinča Institute of Nuclear Sciences, University of Belgrade, Belgrade, Serbia*

<sup>3</sup>*Centre of Excellence in Environmental Chemistry and Engineering-ICTM, University of Belgrade, Serbia*

<sup>4</sup>*State University of Novi Pazar, Department of Chemical-Technological Sciences, Novi Pazar, Serbia*

<sup>5</sup>*Institute of Technical Science of the Serbian Academy of Sciences and Arts, Belgrade, Serbia*  
[sanja@ihtm.bg.ac.rs](mailto:sanja@ihtm.bg.ac.rs)

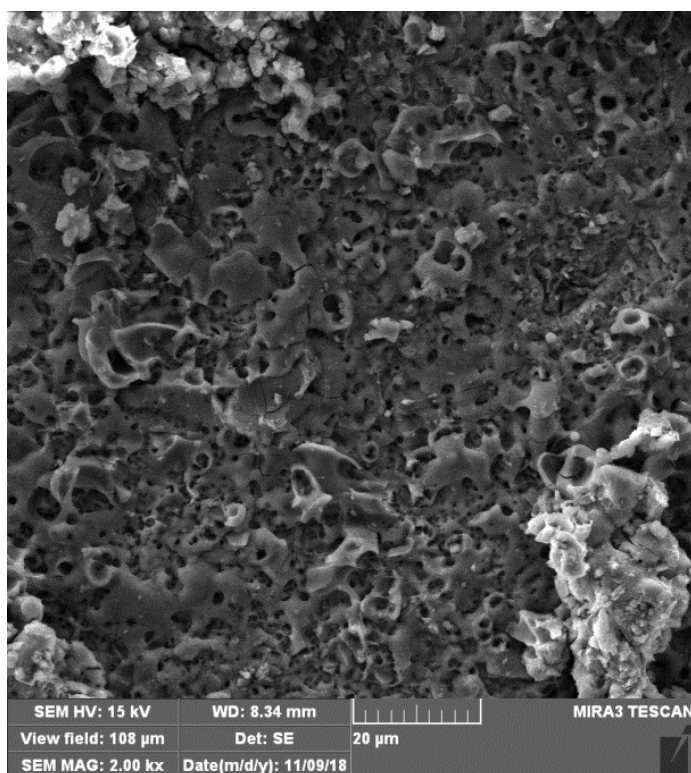

Figure 1. FE-SEM microphotographs of titanium surface after removing anHAP/TiO<sub>2</sub> coating.

The medical devices based on titanium and its alloys are widely used in the repair and replacement of a degraded or inhibited function of locomotor system [1]. Ti and its alloys exhibit high mechanical strength, good workability, resistant to corrosion and low cost. Although, they are widely used as orthopedic and dental implants their inability to interact with living tissue will inhibit their biological fixation and osseointegration [2]. Therefore, to improve the hard-tissue compatibility of Ti various surface treatments have been developed for the inorganic coating formation [3]. The hydroxyapatite (HAp, Ca<sub>10</sub>(PO<sub>4</sub>)<sub>6</sub>(OH)<sub>2</sub>) with superior osteogenic activity is a competitive approach to make novel coatings for titanium implants applications. HAp is a calcium phosphate very similar to the inorganic part of the human bone and hard tissues both in morphology and composition. Herein, *in-situ* synthesis of HAp/TiO<sub>2</sub> coating on titanium was performed via anaphoretic deposition of HAp and simulta-

neous anodization of Ti to produce highly adherent and strengthened composite coating.

It can be seen that morphology of Ti substrate of anHAP/TiO<sub>2</sub> coating is of tubular shape, and tube formation occurs mainly due to competing processes of anodization and electrophoretic deposition of HAp. anHAP/TiO<sub>2</sub> coating does not need sintering process, and simultaneous Ti anodization and HAp deposition occur, where HAp crystals incorporate in the anodized Ti surface. From the presented results it can be concluded that novel suggested process of *in situ* simultaneous anHAP/TiO<sub>2</sub> deposition with Ti surface anodization gives much better results than cathaphoretic deposition regarding adhesion.

### References

1. S.A. Ulasevich, A.I. Kulak, S.K. Poznyak, S.A. Karpushenkov, A.D. Lisenkov, E. V Skorb, RSC Adv. 6 (2016) 62540–62544. doi:10.1039/C6RA10560B.
2. J. Hieda, M. Niinomi, M. Nakai, K. Cho, A. Matsubara, Mater. Trans. 56 (2015) 1703–1710.
3. N. Eliaz, S. Shmueli, I. Shur, D. Benayahu, D. Aronov, G. Rosenman, Acta Biomater. 5 (2009) 3178–3191. doi:http://dx.doi.org/10.1016/j.actbio.2009.04.005.

## Poly(vinyl alcohol)/chitosan hydrogels with electrochemically synthesized silver nanoparticles for wound dressing applications

Vesna Mišković-Stanković<sup>1,2</sup>, Katarina Nešović<sup>1</sup>, Ana Janković<sup>1</sup>, Tamara Radetić<sup>1</sup>, Aleksandra Perić-Grujić<sup>1</sup>, Maja Vukašinić-Sekulić<sup>1</sup>, Vesna Kojić<sup>3</sup>, Kyong Yop Rhee<sup>2</sup>

<sup>1</sup>University of Belgrade, Faculty of Technology and Metallurgy, Belgrade, Serbia

<sup>2</sup>Kyung Hee University, Department of Mechanical Engineering, Yongin, South Korea

<sup>3</sup>University of Novi Sad, Faculty of Medicine, Oncology Institute of Vojvodina, Sremska Kamenica, Serbia  
[vesna@tmf.bg.ac.rs](mailto:vesna@tmf.bg.ac.rs)

In recent times, polymer-based hydrogel materials have presented themselves as excellent candidates for new-generation wound dressings with improved properties, such as high sorption ability, good mechanical properties and low adhesiveness [1]. Additionally, cross linked hydrogel matrices serve as excellent carriers for controlled release of antibacterial agents, such as silver nanoparticles (Ag/NPs), which are preferred over conventional antibiotics due to multi-phase mechanism of action and low susceptibility to induce bacterial resistance [2]. In this work, we aim to produce novel silver/poly(vinyl alcohol)/chitosan (Ag/PVA/CHI) hydrogels for wound dressing applications. The electrochemical route for AgNPs synthesis provided facile and green method for the reduction of Ag<sup>+</sup> ions inside the hydrogel matrices, without the need to use toxic chemical reducing agents [3]. The effect of chitosan content on the synthesis yield, antibacterial properties, swelling and release kinetics was investigated. The formation of AgNPs was confirmed using UV-visible spectroscopy through the appearance of plasmon resonant peaks at around 400 nm (Figure 1a), whereas transmission electron microscopy (TEM) proved the incorporation of both single and polycrystalline spherical AgNPs with diameters of 5-10 nm (Figure 1b). The swelling and silver release kinetics were investigated in modified phosphate buffer solutions (pH 7.4) at 37 °C to mimic physiological conditions. The obtained swelling isotherms and release profiles were fitted with different models to obtain kinetic and diffusion parameters (Figure 1c). The antibacterial activity was evaluated against *Staphylococcus aureus* TL and *Escherichia coli* ATCC 25922 bacterial strains using an in-suspension test, and non-toxicity of both silver-containing and silver-free hydrogels was proved by MTT cytotoxicity test. The obtained results confirmed strong potential of Ag/PVA/CHI hydrogels for biomedical applications.

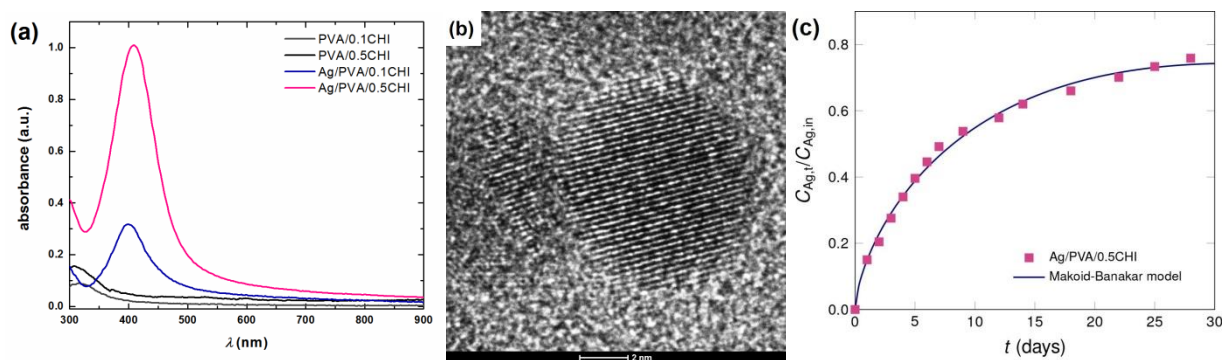

Figure 1. (a) UV-visible spectra of hydrogels with and without AgNPs; (b) TEM micrograph of AgNPs incorporated in Ag/PVA/CHI hydrogel; (c) silver release profile of Ag/PVA/CHI hydrogel with 0.5 wt% CHI fitted with a pharmacokinetic Makoid-Banakar model

### References

- J. Koehler, F.P. Brandl, A.M. Goepferich, *European Polymer Journal* **100** (2018) 1-11. (<https://doi.org/10.1016/j.eurpolymj.2017.12.046>)
- N. Duran, M. Duran, M.B. de Jesus, A.B. Seabra, W.J. Favaro, G. Nakazato, *Nanomedicine: Nanotechnology, Biology and Medicine* **12** (2016) 789-799. (<https://doi.org/10.1016/j.nano.2015.11.016>)
- K. Nešović, A. Janković, V. Kojić, M. Vukašinić-Sekulić, A. Perić-Grujić, K.Y. Rhee, V. Mišković-Stanković, *Composites Part B* **154** (2018) 175-185. (<https://doi.org/10.1016/j.compositesb.2018.08.005>)

## Optimisation of experimental parameters for the electrochemical monitoring of the metals concentration during the waste printed circuit boards recycling process

Graziella Liana Turdean, Eniko Kovacs, Sorin-Aurel Dorneanu

University „Babes-Bolyai“, Faculty of Chemistry and Chemical Engineering,  
Department of Chemical Engineering, 11 Arany Janos St., 400028 Cluj-Napoca, Romania,  
[gturdean@chem.ubbcluj.ro](mailto:gturdean@chem.ubbcluj.ro)

Nowadays there is a great quantity of waste printed circuit boards (WPCBs) that contains significant amounts of heavy metals (like Cu, Sn, Pb, Fe, Zn) and small quantities of precious metals (Au, Ag) [1-2]. These metals from WPCBs could be transferred into solution by leaching, obtaining a complex matrix from where they could be selectively recovered. In this context, from environmental and economic points of view, the electrochemical methods, including electrodeposition, have many advantages in comparison to classically pyrometallurgical, hydrometallurgical [3] alone or coupled with complementary processes (like adsorption, ion-exchange, precipitation, solvent extraction and biochemical treatment [4]).

In order to control rigorously the leaching and recovery processes, the electro-detection of metals could be a simple alternative to the traditional analytical techniques. However, due to the fact that the electro-detection is influenced by the experimental conditions, especially by the potential scan window, their optimization is an important research challenge. The results obtained in synthetic single-metal solutions (Fig 1A) revealed that the peaks for metal electro-deposition/dissolution are well defined and separated. Contrarily, in real samples (RS) of leaching solutions (Fig 1B), it was observed that a large potential scan window lead to a difficult quantification of dissolved metals due to the superposing of the signals. Thus, a restrained potential domain and a rigorous control of other experimental parameters are preferable for individual detection of metals from the WPCBs leaching solutions.

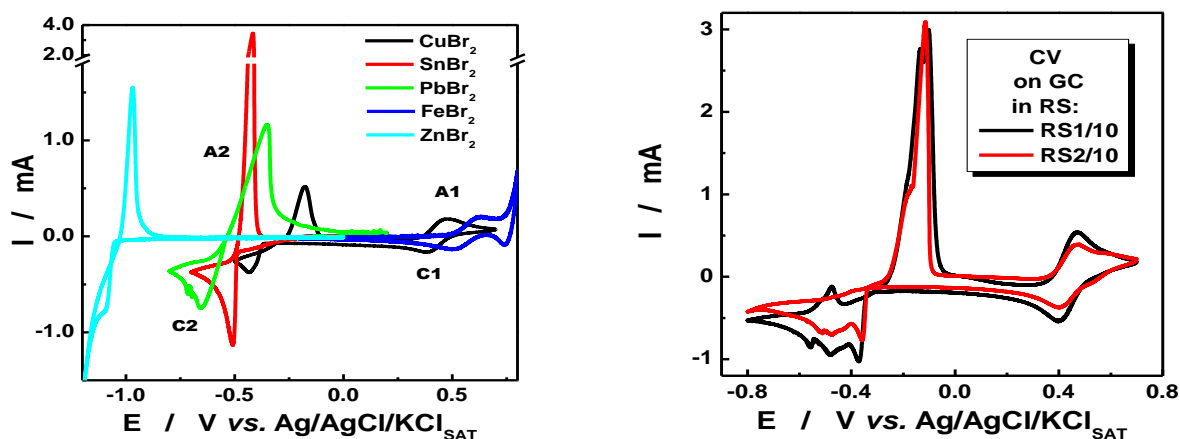

Figure 1. Cyclic voltammograms at GC electrode in 2M KBr + 0.5 HBr M + 0.02 M MeBr<sub>2</sub> (see inset)(A) and in real WPCBs leaching solution (B). Experimental conditions: scan rate, 0.05 V s<sup>-1</sup>.

The main objective of the research was to optimize the experimental parameters of the electro-detection of copper and iron from real WPCBs leaching solutions. The process was studied by cyclic voltametry, square-wave voltammetry and rotating disc electrode, in a restrained scanning potential window at rigorous controlled experimental parameters, like different scan rates, frequencies, or rotation rates, in order to avoid the overlapping of other signals. Also, a mathematical modeling for diminishing the copper signal was proposed for enhances the iron electro-detection.

### References

1. Z. Liu, J. Tang, B.-yi Li, Z. Wang, *J. Clean. Prod.*, **167** (2018) 97-109.
2. F. Cucchiella, I. D'Adamo, S.C. Lenny Koh, P. Rosa, *Renew. Sust. Energ. Rev.* **64** (2016) 749-760.
3. C. Ning, C. S. K. Lin, D. C. W. Hui, G. McKay, *Top. Curr. Chem.*, **375** (2016) 1-36.
4. Huan Li, Jacques Eksteen, Elsayed Oraby, *Resources, Conservation & Recycling*, **139** (2018) 122-139.

## Voltammetric study of base metals recovery from brominated solutions used as lixiviants for waste printed circuit boards

Liana Maria Muresan<sup>1</sup>, Sorin Dorneanu<sup>1</sup>, Eniko Kovacs<sup>1</sup>, Simona Varvara<sup>2</sup>, Petru Ilea<sup>1</sup>

<sup>1</sup>Babes-Bolyai University, Department of Chemical Engineering, 400028 Cluj-Napoca, Romania

<sup>2</sup>University "1 Decembrie 1918" of Alba Iulia, Department of Exact Sciences and Engineering, 510009 Alba Iulia, Romania

[limur@chem.ubbcluj.ro](mailto:limur@chem.ubbcluj.ro)

A study of the dissolution/deposition process of the main metals found in waste printed circuit boards (WPCBs) was carried out by using electrochemical measurements in different Br<sup>-</sup>/Br<sub>2</sub> systems that could be used as lixiviants in hydrometallurgical route of metals recovery. Fast leaching rate, non-toxicity and applicability over a wide range of pH values (from acidic to neutral) are important characteristics of the bromide leaching system<sup>1,2</sup>.

Cyclic voltammetry and polarization measurements were performed in order to characterize the metals dissolution/deposition in the investigated leaching systems from thermodynamic and kinetic points of view. The results were corroborated with morpho-structural analysis of metals after the attack of bromine-based lixiviants.

Preliminary investigations of selective electrodeposition of metals were conducted in order to establish the optimal working conditions. The obtained results recommend the hydrometallurgical route as a promising method for metals recovery from WPCBs.

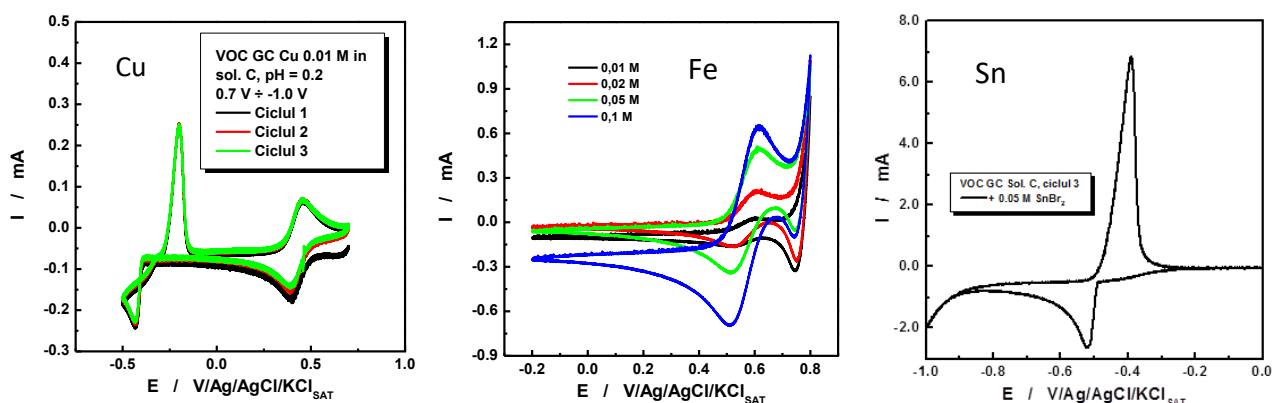

Figure 1. Cyclic voltammograms recorded in 2 M KBr+0.5 M HBr+0.01 M Br<sub>2</sub>, pH = 0.3 solution (Me=Cu, Fe, Sn)

**Acknowledgements:** This work was supported by a grant of the Romanian Ministry of Research and Innovation, CCCDI-UEFISCDI, project number PN-III-P1-1.2-PCCDI-2017-0652/84PCCDI/ 2018, within PNCDI III.

### References

1. M. Melashvili, C. Fleming, I. Dymov, M. Manimaran, J. O'Day, COM Conference of Metallurgists Proceedings ISBN: 978-1-926872-24-7 2014
2. S.-A. Dorneanu, A.-A. Avram, A.-H. Marincas, N. Cotoian, T. Frentiu, P. Ilea, Studia UBB Chemia, LXIII, 4, 2018 p. 147-158

## An EIS study of metals dissolution mechanism in bromide-based electrolytes used as lixiviants for waste printed circuit boards

Simona Varvara<sup>1</sup>, Sorin Aurel Dorneanu<sup>2</sup>, Alexandru Okos<sup>3</sup>, Roxana Bostan<sup>1</sup>, Maria Popa<sup>1</sup>,  
Liana Maria Muresan<sup>2</sup>, Petru Ilea<sup>2</sup>

<sup>1</sup>University "1 Decembrie 1918" of Alba Iulia, Department of Exact Sciences and Engineering,  
510009 Alba Iulia, Romania

<sup>2</sup>"Babes-Bolyai" University, Department of Chemical Engineering, 400028 Cluj-Napoca, Romania

<sup>3</sup> Robert Bosch SRL, Physical and Chemical Analysis Department (RBRO/EQV-A),

Parc Industrial Tetarom 3 Jucu Herghelie 407352, Cluj, Romania

[svarvara@uab.ro](mailto:svarvara@uab.ro)

In the present paper, the dissolution behaviour of Zn, Sn, Fe and Pb in different bromide-based electrolytes has been investigated using electrochemical impedance spectroscopy (EIS) and X-ray photoelectron spectroscopy (XPS) measurements.

Different electrical equivalent circuits have been proposed to broaden understanding the dissolution mechanism of the metals in acidic Br<sup>-</sup>/Br<sub>2</sub> solutions that could be used as lixiviants in the hydrometallurgical route of metals recovery from waste printed circuit boards.

The XPS chemical assessment allowed the identification of the dissolution products formed on the metallic surfaces after exposure to the electrolytes.

Electrochemical measurements showed that the addition of bromine in the system favours to great extents the dissolution process of all studied metals as compared to Br<sub>2</sub>-free electrolytes.

In the investigated experimental conditions, the highest dissolution rates of the metals were obtained in the solution containing 0.01 M Br<sub>2</sub> and they vary in the following order: Zn >> Pb > Sn > Fe.

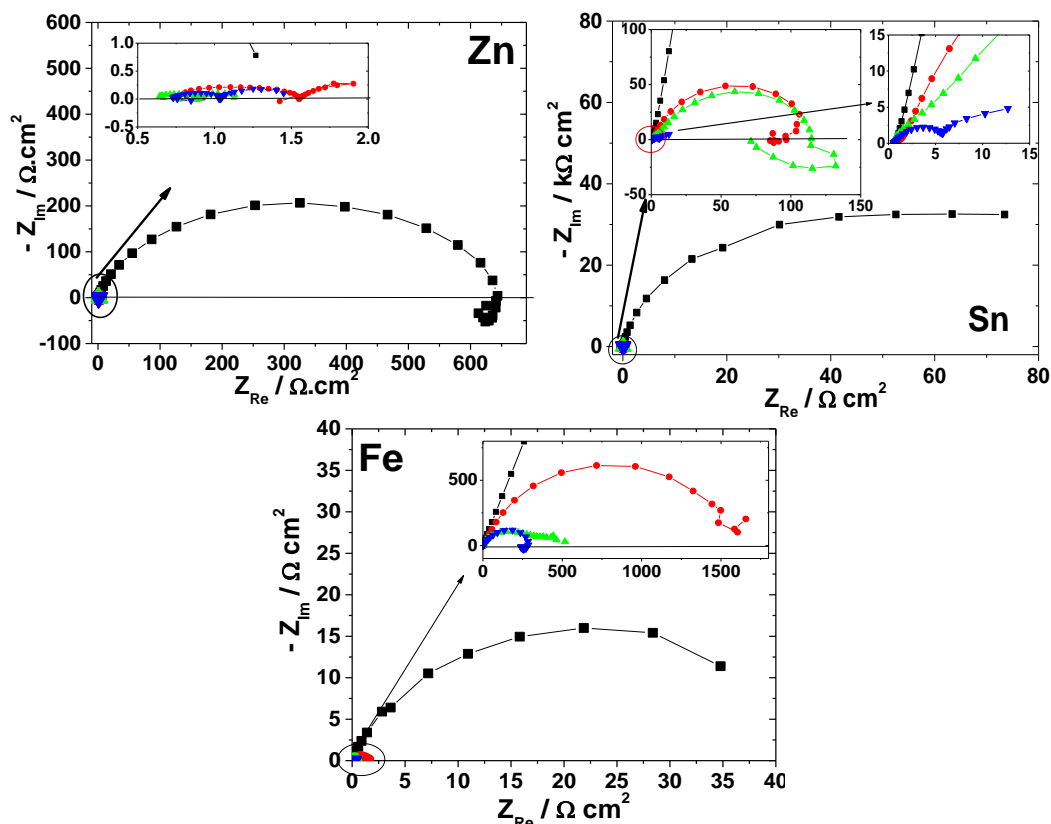

Fig.1. Nyquist diagrams corresponding to metals dissolution in different bromide-based electrolytes: (■) KBr (pH=6); (●) KBr + HBr (pH=0.3); (▲) KBr + HBr + 0.001 M Br<sub>2</sub> (pH=0.3); (▼) KBr + HBr + 0.01 M Br<sub>2</sub> (pH=0.3).

**Acknowledgements.** This work was supported by a grant of the Romanian Ministry of Research and Innovation, CCCDI-UEFISCDI, project number PN-III-P1-1.2-PCCDI-2017-0652/84PCCDI/2018, within PNCDI III.

## Magnetic biomass-derived pyrolytic carbon: an advanced electrode material for applications in bioelectrocatalysis and electrochemical sensing

Egon Rešetar, Damir Iveković

*Laboratory for general and inorganic chemistry and electroanalysis, Faculty of food technology and biotechnology, University of Zagreb, Pierottijeva 6, HR-10000 Zagreb, Croatia*

[eresetar@pbf.hr](mailto:eresetar@pbf.hr), [divekov@pbf.hr](mailto:divekov@pbf.hr)

Biomass-derived carbons comprise a large class of structurally and morphologically diverse carbon materials produced by the pyrolytic or hydrothermal carbonization of biomass, most commonly the cellulosic, hemicellulosic or lignocellulosic plant wastes. Due to their good electrical conductivity, mesoporous structure, large specific surface area and tunable surface properties, biomass-derived carbons recently received a considerable interest as advanced and sustainable electrode materials for energy storage applications, electrocatalytic oxygen reduction and hydrogen evolution.

Here we report on our recent research focused on development and characterization of magnetic biomass-derived pyrolytic carbon materials for applications in bioelectrocatalysis and electrochemical sensing. Pyrolytic carbon samples were prepared by carbonization of waste coffee grounds at 600-850 °C in an inert (N<sub>2</sub>) atmosphere, in the presence of iron(III) salt as a graphitization catalyst, followed by the acid leaching of iron residues from the solvent-accessible surface of carbon particles. Pyrolytic carbons showing good electrical conductivity, well-developed mesoporosity and high specific surface area of 180-210 m<sup>2</sup>/g were obtained at pyrolysis temperatures above 700 °C, preferably at 800-850 °C. Structurally, these samples comprised of elongated graphitic nanodomains embedded into the amorphous carbon matrix containing randomly dispersed cementite (Fe<sub>3</sub>C) nanoparticles of 5-50 nm in size, formed as a by-product of the iron-catalyzed graphitization process. Due to the presence of the cementite phase, pyrolytic carbons obtained under the aforementioned conditions exhibited ferromagnetic properties, which allow them to be easily manipulated by means of an external magnetic field.

Magnetically active pyrolytic carbon (MPC) was employed as an electrically conductive substrate for immobilization of horseradish peroxidase (HRP), a well-known model redox enzyme that catalyzes the reduction of hydrogen peroxide in the presence of a suitable electron donor or, in the special case of HRP adsorbed on electrode, through the process of direct electron transfer between the electrode and enzyme redox center. HRP-modified MPC was employed for fabrication of porous film-electrodes, which were kinetically characterized under the conditions of direct and mediated bioelectrocatalysis. The obtained results showed that the HRP immobilized on MPC retains its catalytic activity and is able to participate in direct electron transfer at potentials slightly cathodic to the formal potential of the heme(Fe<sup>III</sup>)/heme(Fe<sup>II</sup>) redox couple of HRP. It was found that the bioelectrocatalytic activity and long-term catalytic stability of electrodes prepared from HRP-modified MPC were significantly higher than the activity and stability of electrodes prepared from HRP immobilized on graphite powder. Since the results of kinetic modelling showed that the kinetic parameters of HRP immobilized on MPC do not differ significantly from the kinetic parameters of HRP immobilized on plain graphite, the observed increase in the performances of bioelectrocatalytic electrodes prepared from HRP-modified MPC can be attributed to the high specific surface area of MPC and the confinement of HRP within the mesopores of MPC, a mean diameter of which was found to be comparable with the size of HRP molecules.

Two examples of advanced application of MPC in bioelectrocatalysis that rely on the ferromagnetic properties of MPC were demonstrated, one related to the application of MPC in fabrication of magnetically renewable porous film bioelectrodes and the second related to fabrication of electrochemical paper-based microfluidic sensors. The latter is especially interesting because it was found that MPC-based inks can be focused by means of an inhomogeneous magnetic field, which opens the perspectives for producing electrically conductive and bioelectrocatalytically active patterns on paper substrates without the use of conventional printing tools.

## Design of semiconductor (photo)catalysts and investigation of their electronic structure

Jozefina Katić<sup>1</sup>, Zoran Grubač<sup>2</sup>, Mirjana Metikoš-Huković<sup>1</sup>

<sup>1</sup>Department of Electrochemistry, Faculty of Chemical Engineering and Technology,  
University of Zagreb, Savska c. 16, 10000 Zagreb, Croatia

<sup>2</sup>Department of General and Inorganic Chemistry, Faculty of Chemistry and Technology,  
University of Split, Ruđera Boškovića 35, 21000 Split, Croatia

[jkatic@fkit.hr](mailto:jkatic@fkit.hr)

Significant efforts have been made to develop new semiconductor catalysts for energy conversion and photocatalytic degradation of organic pollutants, pigments and dyes [1-3]. It is challenging to identify, and design new semiconductor materials that are efficient, stable and abundant. Therefore, the knowledge of fundamental semiconductor (photo)electrochemistry principles is of the great importance.

The crucial step in photoelectrochemical processes connected with solar energy conversion, including (photo)catalytic organic pollutant degradation is electron transfer, which occurs between the same energy levels of semiconductor and redox electrolyte species [1,2] at the semiconductor|electrolyte interface.

The flat band potential,  $E_{FB}$  (Fermi level) as experimentally determined parameter, correlates the electron transfer between the semiconductor and the electrolyte solution and is linked to the semiconductor's band edge position. For  $E_{FB}$  determination, the Mott-Schottky (MS) analysis or photocurrent measurements can be used. In this work special attention was given to the accuracy of  $E_{FB}$  determination.

The aim of this work was also to broaden the photocatalytic system forward from single component catalyst's to multi-component configuration. Composite semiconductor-semiconductor junction structure of the n-type  $\text{Bi}_2\text{S}_3$  (narrow-band gap semiconductor), and the n-type  $\text{Bi}_2\text{O}_3$  (wide-band gap semiconductor) was proposed. Both semiconductors have recently attracted much attention due to the natural abundance, non-toxicity, high catalytic activity and excellent electrical conductivity [3-5]. Bi-films, formed potentiostatically on bismuth in an aqueous sodium hydroxide solution with and without the addition of sulfide ions, were investigated using cyclic voltammetry (CV), electrochemical impedance spectroscopy (EIS), and diffuse reflectance spectroscopy (DRS).

The energy-band diagram for the proposed composite structure, n- $\text{Bi}_2\text{S}_3$ | n- $\text{Bi}_2\text{O}_3$ , was constructed taking into account the semiconducting parameters of the both semiconductors (deduced from the Mott-Schottky analysis and Tauc plots) and the thermodynamic data for the redox reactions occurring at the semiconductor|electrolyte interface. Special attention was given to the reactions that include the formation of free radical species prerequisite for the solar-driven photocatalytic degradation processes of organic pollutants. Absolute energy values of the conduction band edge,  $E_{CB}$  and the valence band edge,  $E_{VB}$  positions of n- $\text{Bi}_2\text{O}_3$  and n- $\text{Bi}_2\text{S}_3$  were deduced from the  $E_{FB}$  (Fermi level) and correlated with the semiconductor's stability against decomposition. The n- $\text{Bi}_2\text{S}_3$  | n- $\text{Bi}_2\text{O}_3$  catalyst satisfies simultaneously the light adsorption and charge separation criteria, acting as possible suitable visible light-driven catalyst in advanced oxidation processes for wastewater treatment application.

### References

1. S. Bai, J. Jiang, Q. Zhang, Yujie Xiong, *Chem. Soc. Rev.* **44** (2015) 2893-2939. (<https://doi.org/10.1039/C5CS00064E>)
2. M. Kovačić, J. Katić, H. Kušić, A. Lončarić Božić, M. Metikoš-Huković, *Materials* **11** (2018) 1041.1-1041.19.
3. (<https://dx.doi.org/10.3390%2Fma11061041>)
4. D. Ayodhya and G. Veerabhadram, *Mater. Today Energ.* **9** (2018) 83-113.
5. (<https://doi.org/10.1016/j.mtener.2018.05.007>)
6. Z. Grubač, M. Metikoš-Huković, *J. Electroanal. Chem.* **565** (2004) 85-94. (<https://doi.org/10.1016/j.jelechem.2003.09.036>)
7. W. Huang, C. Xing, Y. Wang, Z. Li, L. Wu, D. Ma, X. Dai, Y. Xiang, J. Li, D. Fan, H. Zhang, *Nanoscale* **10** (2018) 2404-2412. (<https://doi.org/10.1039/C7NR09046C>)

## Frequency response analysis of oxygen reduction reaction in alkaline media

Saikrishnan Kandaswamy, Tanja Vidaković-Koch

Max Planck Institute for Dynamics of Complex Technical Systems,  
Sandtorstraße 1, 39106 Magdeburg, Germany  
[vidakovic@mpi-magdeburg.mpg.de](mailto:vidakovic@mpi-magdeburg.mpg.de)

The oxygen reduction reaction (ORR) is regarded as one of the most important electrocatalytic reaction because of its role in electrochemical energy conversion systems and several industrial processes. The efficiencies of these electrochemical processes are strongly influenced by the slow and complex kinetics of the ORR. One example of interest is chlor-alkali electrolysis with oxygen depolarized cathode. In this process, the ORR takes place at silver gas diffusion electrode (Ag-GDE), under strongly alkaline conditions and at elevated temperatures. Although, ORR is a well-studied reaction, there is only little knowledge on micro kinetics ORR under conditions relevant for chlor-alkali electrolysis. By using nonlinear frequency response analysis (NFRA) micro kinetics of ORR is studied in model silver electrode [1-2]. In NFRA a set of frequency response functions (FRF), which contain different information about the properties of the electrochemical system are obtained. The first FRF contains the linear part of the response and is identical to the electrochemical admittance (inverse of the EIS). The higher FRFs include the nonlinearities of the system response and especially the second order FRF was proven useful for model discrimination [3]. A large amplitude sinusoidal potential input is applied to the ORR system, output current response is measured and converted to frequency domain by using fast Fourier transform (FFT). Finally, experimental FRF's are calculated from the FFT results [1-3]. Experimental first and second order FRFs obtained under conditions of different sodium hydroxide concentrations (0.1-11 M) and at different temperatures. These experimental FRFs is compared with theoretical FRF to describe the model. The experiments with rotating ring disk electrode (RRDE) also used to investigate output of ORR.

### Reference

1. T. Vidaković-Koch, V. Panić, M. Andrić, M. Petkovska, K. Sundmacher, *J. Phys. Chem. C* **115** **35** (2011) 17341-17351 (<https://pubs.acs.org/doi/abs/10.1021/jp201297v>).
2. V. Panić, T. Vidaković-Koch, M. Andrić, M. Petkovska, K. Sundmacher, *J. Phys. Chem. C* **115** **35** (2011) 17352-17358 (<https://pubs.acs.org/doi/abs/10.1021/jp201300a>).
3. B. Benschmann, M. Petkovska, T. Vidaković-Koch, R. Hanke-Rauschenbach, K. Sundmacher, *J. Electrochem. Soc.* **157** **9** (2010) B1279-B1289 (<http://jes.ecsdl.org/content/157/9/B1279>).

## Mitigating mass transport limitations of PEFCs during dynamic operation

Bernhard Marius<sup>1</sup>, Zeljko Penga<sup>2</sup>, Viktor Hacker<sup>1</sup>

<sup>1</sup>Institute of Chemical Engineering & Environmental Technology, TU Graz

<sup>2</sup> Faculty of Electrical Engineering, Mechanical Engineering and Naval Architecture, University of Split  
[b.marius@tu-graz.at](mailto:b.marius@tu-graz.at)

The performance and lifetime of polymer electrolyte fuel cells are very much dependent on conditions and modes of operation. During steady state operation of the fuel cell, the conditioning parameters like stoichiometry, pressure, temperature and humidity can be continuously adjusted to achieve a constant high performance of the fuel cell. In dynamic operation of the fuel cell, it is very challenging to monitor and control the fast changing conditions inside the cell.

Fast and disruptive changes are performed in these experiments either by load or voltage steps. By observing the voltage response of a load change it is possible to get fundamental details on the mass transport mechanisms inside the fuel cell. Fig. 1 shows a typical voltage response of polymer electrolyte single cell caused by a step load change. It can be seen that the overall voltage decreases and the single electrode potentials are not considered here [1,2]. The critical under- and overshoot as well as the delay time to reach the steady state are indicated by the green lines. These phenomena are caused by mass transfer limitations that occur if the supply of protons and electrons cannot match the current demand of the load.

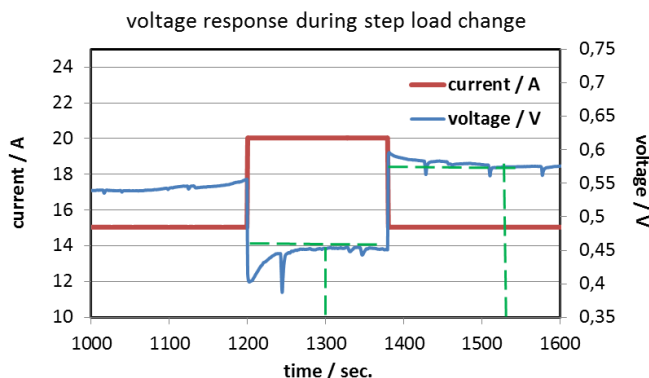

Figure 2. Voltage response of a step load change

The under- and overshoot can cause harmful voltage levels that accelerate the degradation of the cell. The low voltage after an increasing load step is caused by membrane dry out. The dry out is generated by a combination of heat production on the cathode and electroosmotic drag on the anode. This causes a resistance increase (vice versa for the stepwise load decrease). The course of the resistance follows an exponential curve until the membrane humidity reaches the corresponding steady state level. The time that is necessary to reach steady state conditions is corresponding to the hydration time of the membrane after the dry out. To counteract these undesirable effects, the increase of gas humidity, stoichiometry or gas pressure is possible. The extent of humidity, stoichiometry and pressure increase to vanish voltage over- and undershooting depends on the range of the load step and the initial operation conditions. A suitable monitor technic and control strategies for the fuel cell, balanced between efficiency and life time, will be discussed.

*Acknowledgement:* This project is funded by the "Klima- und Energiefonds" and is conducted within "Energieforschungsprogramm".

### References

1. Baumgartner W.R., Parz P., Fraser S.D., Wallnoefer E., Hacker V. (2008) J. Power Sources, 182, 413–421.
2. Ramschak E., Baumgartner W.R., Hacker V., Prenninger P. (2008) World Electric Vehicle Assoc. J., 2, 23–29.

## Enhancement of the mass transport by numerical simulation in an electrochemical reactor with concentric cylindrical electrodes

Petru Ilea<sup>1</sup>, Marius Ioan Purcar<sup>2</sup>, Sorin-Aurel Dorneanu<sup>1</sup>, Alexandru Horațiu Marincaș<sup>1</sup>

<sup>1</sup>Babes-Bolyai University, Department of Chemical Engineering, 400028 Cluj-Napoca, Romania

<sup>2</sup>Technical University of Cluj-Napoca, Electrotechnics and Measurements Department, 400027 Cluj-Napoca, Romania

[pilea@chem.ubbcluj.ro](mailto:pilea@chem.ubbcluj.ro)

The mass transport enhancement in electrochemical reactors for metal extraction is essential for developing an energy-efficient process and for obtaining the extracted metal as a consistent (uniformly thick) deposit. Such as performances can be obtained for various electrode configurations under convective intensified mass transport conditions [1, 2]. The concentric cylindrical electrodes reactor (CCER) with axial (ascending) electrolyte flow between the electrodes, provides a uniform distribution of current density that leads to a uniform deposition at the cathode even after a long electrodeposition time (*e.g.* hours).

The aim of the study is to determine the effect of the operating parameters (geometrical, hydrodynamical and electrochemical) in order to enhance (increase) the mass transport during the copper electrodeposition for a solution resulted from the WEEE processing [3]. The study is based on the numerical simulation on a CCER formed of two compartments separated by an anionic ion exchange membrane for the imposed Cu concentration at cathode chamber inlet of 400 mol/m<sup>3</sup>, the average cathodic current density of -500 A/m<sup>2</sup> and the expected efficiency of 90%. The electrolyte density is  $\rho = 1100\text{kg/m}^3$  and the dynamic viscosity is  $\mu = 1.32 \cdot 10^{-3} \text{ kg/(m.s)}$ . The computational model of the CCER is shown in Figure 1a). The Cu concentration (Cu), diffusion layer thickness (diff), current density (J) and layer thickness distributions (d) at the cathode are presented in figures 1b) to 1e), respectively.

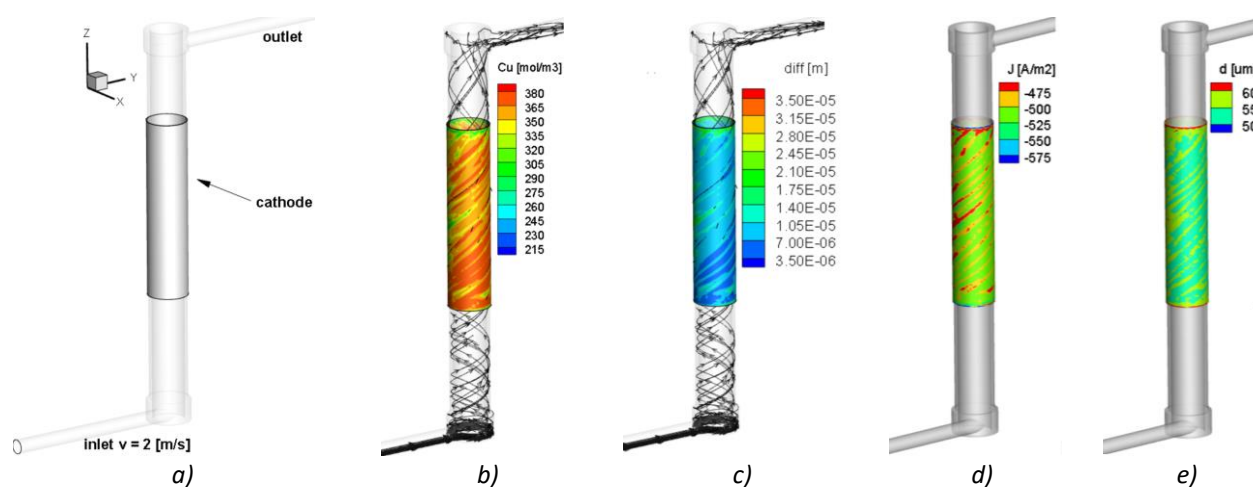

Figure 1. Computational model a), Cu concentration b), diffusion layer thickness c), current density d) and layer thickness distribution e) at the cathode.

**Acknowledgements:** Financial support from Project PN III - TRADE-IT - PCCDI no. 84/2018 financed by the UEFISCDI Romania is acknowledged

### References

1. Frank C. Walsh, Carlos Ponce de León, *Electrochimica Acta* 280 (2018) 121-148, Progress in electrochemical flow reactors for laboratory and pilot scale processing.
2. Keith Scott, *Renewable and Sustainable Energy Reviews* 81 Part 1 (2018) 1406-1426, Process intensification: An electrochemical perspective.
3. S.-A. Dorneanu, A.-A. Avram, A.-H. Marincaș, N. Cotolan, T. Frențiu, P. Ilea, *Studia UBB Chemia*, LXIII, 4, (2018) 147-158, Influence of the composition evolution of waste computer motherboards on their recycling strategy.

# **Corrosion Science and Protection**

## Corrosion behaviour of Al alloys in reline

Mihael Bučko, Jelena B. Bajat<sup>1</sup>

*University of Defence, Military Academy, 33 Pavla Jurišića Šturma St, 11000 Belgrade, Serbia*

<sup>1</sup>*Faculty of Technology and Metallurgy, University of Belgrade, Karnegijeva 4, 11000 Belgrade, Serbia*

[mbucko@tmf.bg.ac.rs](mailto:mbucko@tmf.bg.ac.rs)

Deep eutectic solvents have been investigated intensively in the last two decades, in various applications: electrochemical deposition, electrolytes in energy storage devices, oil purification, carbon dioxide absorption, etc. [1]. However, the literature regarding the corrosion behaviour of metals and alloys in these electrolytes, is significantly scarce [2].

The corrosion of aluminium alloys of series AA 2024 and AA 6065, immersed in choline chloride-urea deep eutectic solvent (reline), was studied using electrochemical techniques (polarization curves and electrochemical impedance spectroscopy). The initial corrosion rates are very low, but increase with time due to water absorption from the atmosphere. Most of the tests in this work have been performed at 60 °C, because this is the typical operating temperature of reline. At this temperature, the water content in the electrolyte is low, and consequently, the measured corrosion rates are low. This leads to the conclusion that the main cathodic reactions which induce Al corrosion, are oxygen and water reduction. In other words, the organic compounds of reline do not increase Al corrosion rate, but instead act as corrosion inhibitors. Due to the high chloride concentration in reline, pitting corrosion is observed in the two aluminium alloy types investigated.

### References

1. E. L. Smith, A. P. Abbott, K. S. Ryder, *Chemical Reviews* **114** (2014) 11060
2. D. Marino, M. Shalaby, S. Kriescher, M. Wessling, *Electrochemistry Communications* **90** (2018) 101

## Substitution of chromium conversion coatings (CCC) by cerium oxide layers (CeOPL) deposition for protection of aluminium aircraft alloys

Christian Girginov<sup>1</sup>, Stephan Kozhukharov<sup>2</sup>

<sup>1</sup>Department of Physical Chemistry, University of Chemical Technology and Metallurgy - Sofia, Bulgaria

<sup>2</sup>Laboratory for Advanced Materials Research, University of Chemical Technology and Metallurgy - Sofia, Bulgaria

The recently accepted environmental restrictions in EU and USA have imposed the need to substitute the use of heavy metal compounds, for instance chromates, during the initial and external coating deposition. In this sense, lately lanthanides and especially cerium appear to be the most perspective candidates for elaboration of durable and reliable Cerium Oxide Primer Layers (CeOPL) as protective primers for widely used aircraft alloys, such as AA2024-T3 and AA7075-T6. In this aspect, the present brief review summarizes the recent trends in the determination of the optimal regime parameters for deposition of such CeOPL primers using both electrochemical (*i.e.* tensiostatic and galvanostatic) and electroless (spray or dip-coating) methods. Thus, examples for: (i) the optimal Ce-compound type and concentration, (ii) addition of deposition activator, (iii) the optimal applicable current and/or potential and (iv) the working temperature are described.

*Acknowledgements:* The authors are grateful for the funding of this research to the Bulgarian National Scientific Research Fund, under contract BNSF: DM-19/6 – 2017.

### References

1. S. V. Kozhukharov (2016), **Chapter 2:** Deposition of Environmentally Compliant Cerium-Containing Coatings and Primers on Copper-Containing Aluminium Aircraft Alloys, PUBLISHED IN: Biobased and Environmental Benign Coatings (eds A. Tiwari, A. Galanis and M. D. Soucek), John Wiley and Sons Ed. ISBN: 9781119185055.
2. R. Andreeva, E. Stoyanova, A. Tsanev, M. Datcheva, D. Stoychev, On the Role of pre-treatment of Aluminum Substrate on Deposition of Cerium Based Conversion Layers and Their Corrosion-Protective Ability, *Int. J. Electrochem. Sci.* **13** (2018) 5333.
3. S. V. Kozhukharov, V. I. Samichkov, Ch. A. Girginov, M. S. Machkova, Actual trends in the elaboration of advanced multifunctional coating systems for the efficient protection of lightweight aircraft alloys, *Corrosion Reviews*, **35** (2017) 383.
4. S. Kozhukharov, Ch. Girginov, Enhancement of the cerium oxide primer layers deposited on AA2024-T3 aircraft alloy by preliminary Enhancement of the cerium oxide primer layers deposited on AA2024-T3 aircraft alloy by preliminary anodization, *J. Electrochem. Sci. Eng.* **8** (2018) 113.

## Evaluation of the electrochemical performance of Ag incorporated AAO layers after extended exposure to a model corrosive medium

Stephan Kozhukharov<sup>1</sup>, Christian Girginov<sup>2</sup>, Aleksandar Tsanev<sup>3</sup>, Georgy Avdeev<sup>4</sup>, Boriana Tzaneva<sup>5</sup>

<sup>1</sup>Laboratory for Advanced Materials Research, University of Chemical Technology and Metallurgy – Sofia, Bulgaria

<sup>2</sup>Department of Physical Chemistry, University of Chemical Technology and Metallurgy – Sofia, Bulgaria

<sup>3</sup>Institute of General and Inorganic Chemistry, Bulgarian Academy of Sciences – Sofia, Bulgaria

<sup>4</sup>Institute of Physical Chemistry, Bulgarian Academy of Sciences – Sofia, Bulgaria

<sup>5</sup>Faculty of Electronic Engineering and Technologies, Technical University – Sofia, Bulgaria

The coating procedure appears to be an indispensable finishing stage in the production of Al based industrial products, engineering facilities and equipment. For this reason, there is an ever increasing interest towards the elaboration of reliable corrosion protective layers with apparent coverage, adhesion and barrier properties. In this sense, both the anodized alumina oxide (AAO) layer formation and the further Ag-incorporation enable the elaboration of advanced Al-O-Ag films with extended beneficial characteristics. The present research activities are aimed at the determination of the corrosion protective properties of electrochemically synthesized Al-O-Ag layers on technically pure AA1050 alloy. Two independent methods were used for their electrochemical characterization: Electrochemical Impedance Spectroscopy (EIS) and Linear Voltammetry (LVA). The electrochemical measurements were performed after 24, 168 and 672 hours of exposure to a model corrosive medium (3.5% NaCl solution), in order to determine the barrier properties and durability of the elaborated Al-O-Ag layers. The research activities were accomplished by additional structural analyses via X-ray Diffractometry (XRD) and X-ray Photoelectron Spectroscopy (XPS). The analysis of the obtained results has undoubtedly shown that the proposed electrochemical Al-O-Ag layer deposition can be successfully used for creation of self-standing decorative layers with apparent protective properties. Besides, the Al-O-Ag can be used as a basis for development of Metal-Oxide-Semiconductor (MOS) systems by additional metallization.

*Acknowledgements:* The authors appreciate the financial support from the Bulgarian National Research Fund, via contract No: КП-06-H29/1.

### References

1. S. V. Kozhukharov, and Ch. A. Girginov, *Bulg. Chem. Commun.* **A-50** (2018) 13.
2. Ch. A. Girginov, S. V. Kozhukharov, and M. J. Milanec, *Bulg. Chem. Commun.* **A-50** (2018) 6.
3. Ch. Girginov, S. Kozhukharov, M. Milanec, and M. Machkova, *Mater. Chem. Phys.* **198** (2017) 137.
4. Ch. Girginov, S. Kozhukharov, D. Kiradzhyska, and R. Mancheva, *Electrochim. Acta*, **292** (2018) 614.
5. D. Kiradzhyska, R. Mantcheva, Ch. Girginov, and S. Kozhukharov, *J. Chem. Technol. Metall.*, **53** (2018) 745.
6. S. Kozhukharov, M. Milanec, Ch. Girginov, and M. Machkova, *Mater. Corros.* **67** (2016) 710.

## From organic synthesis to testing of compounds with different anchor groups as corrosion inhibitors for aluminium

Dolores Zimerl, Stojan Stavber, Ingrid Milošev

Jožef Stefan Institute, Jamova c. 39, SI-1000 Ljubljana, Slovenia

[dolores.zimerl@ijs.si](mailto:dolores.zimerl@ijs.si)

The use of organic corrosion inhibitors is one of many possible methods for metal surface protection. Organic inhibitors exhibit a lot of desirable properties such as: effectiveness at wide range of temperatures, compatibility with different materials, good solubility in water and low cost. Organic inhibitors form a protective film formed by absorption of molecule on the surface. Potentially good organic inhibitors contain nitrogen, oxygen, sulphur or phosphorous with lone electron pair in their structure [1].

Despite that organic synthesis and corrosion protection use completely different methods and work strategies, both can go hand in hand toward one goal. In our recent work we combined the knowledge of organic synthesis and electrochemical measurements to investigate inhibitive properties of five compounds with octyl chain on one side of molecule, and different anchor group on the other side.

In the first step, modifications of simple substitution and oxidation were used to prepare octyl azide (1), N-octylimidazole (2), octyl thiocyanate (3) and octylphosphonic acid (4) and dioctyl disulphide (5) [2-7].

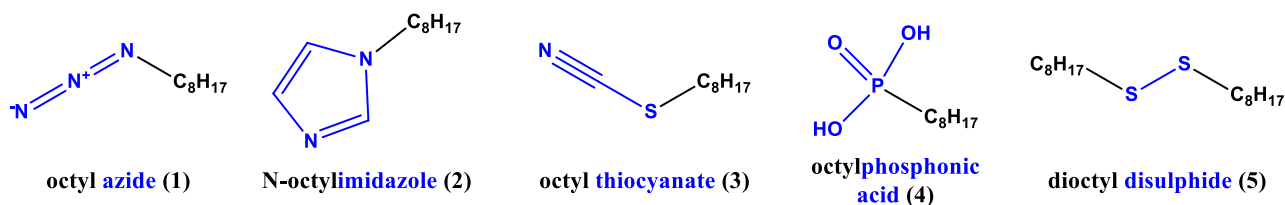

Figure 1: Structure formula of synthesised organic inhibitors 1-5

In the second step, aluminium surface was prepared by grinding and alkaline etching. After sample preparation samples were immersed in ethanolic solution of compounds (1-5) to form self-assembled layer on the surface. Samples were further investigated by electrochemical measurements (potentiodynamic curves) and long-term immersion test in saline water. Based on the results we could evaluate the effect of anchor group on corrosion inhibition properties for alkaline etched aluminium.

Acknowledgment: This work is a part of M-ERA.NET project entitled "Design of corrosion resistant coatings targeted for versatile applications" (acronym COR\_ID). The financial support of the project by MESS (Ministry of Education, Science and Sport of Republic of Slovenia), ANR (The French National Research Agency) and NKFIH OTKA (National Research Development and Innovation Office, Hungary) is acknowledged.

### References

1. B. E. Brycki, I. H. Kowalczyk, A. Szulc, O. Kaczerewska, M. Pakiet, *Organic corrosion inhibitors* (2018) 1-33 (<http://dx.doi.org/10.5772/intechopen.72943>)
2. V. N. Emel'yanenko, M. Algarra, J. C. G. Esteves da Silva, J. Hierrezuelo, J. M. López-Romero, S. P. Verevkin, *Thermochimica Acta* **597** (2014) 78-84 (<https://doi.org/10.1016/j.tca.2014.10.015>)
3. A. A. Salman, M. Tabandeh, T. Heidelberg, R. S. D. Hussien, H. M. Ali, *Carbohydrate Research* **412** (2015) 28-33 (<https://doi.org/10.1016/j.carres.2015.04.022>)
4. R. J. Capon, C. Skene, E. Hasang-Te Liu, E. Lacey, J. H. Gill, K. Heiland, T. Friedel, *Journal of Natural Products* **67** (2004) 1277-1282 (<https://doi.org/10.1021/np049977y>)
5. X. Zhou, J. Huang, K. W. Barr, Z. Lin, F. Maya, L. J. Abbott, C. M. Colina, F. Svec, S. R. Turner *Polymer* **59** (2015) 42-48 (<https://doi.org/10.1016/j.polymer.2014.12.065>)
6. P. G. Mingalyov, M. V. Buchnev, G. V. Lisichkin, *Russian Chemical Bulletin* **50** (2001) 1693-1695 (<https://doi.org/10.1023/A:1013067409225>)
7. V. Kesavan, D. Bonnet-Delpon, J. P. Bégué, *Synthesis* **2** (2000) 223-225 (<https://doi.org/10.1055/s-2000-6262>)

## Sol-gel coating based on zirconium(IV) isopropoxide and epoxysilane for corrosion protection of aluminium alloy in deep-sea environment

Barbara Kapun, Ingrid Milošev

Jožef Stefan Institute, Jamova cesta 39, 1000 Ljubljana, Slovenia

[barbara.kapun@ijs.si](mailto:barbara.kapun@ijs.si)

Aluminium alloy AA7075-T6 is commonly used for many industrial applications, mainly in the aircraft industry. Its use in marine industry is limited due to high susceptibility to localised corrosion due to heterogeneous microstructure of the alloy. In marine environment bio-fouling is a major problem due to interactions of metal surface with water and marine organisms [1].

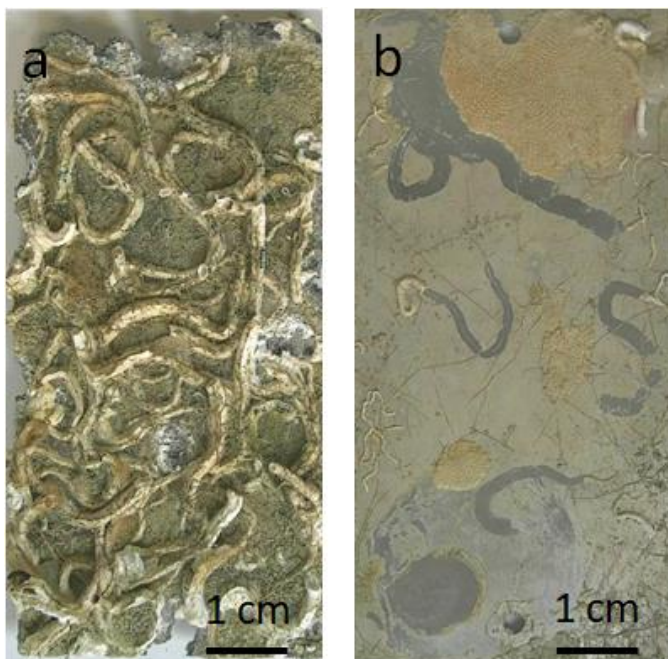

Figure 1. Surface appearance of a) uncoated and b) coated AA7075-T6 after 8 months immersion in Adriatic Sea

Nawadays many studies in antifouling systems are devoted to the development of pre-treatments and coatings that would enable the replacement of toxic and environmentally hazardous additives such as copper (ref.). Hybrid sol-gel coatings are considered as good candidates for replacement of toxic systems and offer also possibilities to improve the anti-fouling ability [2].

The aim of this study is focused on the field testing of AA7075-T6 in the Adriatic Sea. Bare samples and samples protected by sol-gel coatings were subjected to relevant experiment including biofilm formation.

The sol-gel coating denoted as ZG is based on zirconium(IV) isopropoxide and 3-glycidylloxypropyl)trimethoxysilane as precursors and acetic acid as a catalyst [3].

Uncoated and coated samples were embedded in a Teflon rack and immersed 2 miles from the coast at the depth of 20 m. The samples were taken out

at different time periods. After the test, the samples were sonicated to remove the biofilm and analysed with electrochemical potentiodynamic measurements and electrochemical impedance spectroscopy (EIS). The surface of samples was characterised using scanning electron microscopy coupled with energy dispersive X-ray spectroscopy (SEM/EDS) and a focused ion beam (FIB) microscopy.

After immersion test uncoated AA7075-T6 have severe localised damage, Fig. 1a. In contrast, the coated alloy remained efficiently protected even long-term exposure in the natural marine environment, Fig. 1b. Moreover, applied coating also reduce the formation of biofilm.

**Acknowledgments:** This work is a part of M.ERA-NET project entitled "Design of corrosion resistant coatings targeted for versatile applications" (acronym COR\_ID). The financial support of the project by MESS (ministry of Education, Science and Sport of Republica of Slovenia) is acknowledged. The National Institute of Biology is acknowledged for the use of oceanographic field facility at the Marine Biology Station in Piran.

### References:

1. E. Canepa, R. Stifanese, L. Merotto, P. Traverso, *Marine Structures* **59** (2018) 271–284 (<https://doi:10.1016/j.marstruc.2018.02.006>).
2. A. G. Nurioglu, A.C. C. Esteves, G. de With, *Journal of Materials Chemistry B* **3** (2015) 6547–6570 (<https://doi:10.1039/C5TB00232J>).
3. I. Milošev, B. Kapun, P. Rodič, J. Iskra, *Journal of Sol-Gel Science Technology* **74** (2015) 447–459 (<https://doi:10.1007/s10971-015-3620-9>).

## Corrosion resistance of niobium coatings on copper bipolar plates for proton exchange membrane electrolyzers

Andrea Kellenberger, Nicolae Vaszilcsin, Delia Duca, Mircea Laurentiu Dan, Narcis Duteanu, Svenja Stiber<sup>1</sup>, Pia Assmann<sup>1</sup>, Aldo S. Gago<sup>1</sup>, K. Andreas Friedrich<sup>1</sup>

Politehnica University Timisoara, Faculty of Industrial Chemistry and Environmental Engineering, Piata Victoriei No. 2, 300006 Timisoara, Romania

<sup>1</sup>Institute of Engineering Thermodynamics, German Aerospace Center, Pfaffenwaldring 30-40, Stuttgart, 70569, Germany  
[andrea.kellenberger@upt.ro](mailto:andrea.kellenberger@upt.ro)

Proton exchange membrane (PEM) water electrolysis is a green procedure for hydrogen production but to become competitive in terms of costs with classical methods such as coal gasification and methane reforming, a game changer in the technology is necessary. This is the aim of PRETZEL project, which proposes a patented innovative concept of the electrolysis cells based on hydraulic compression [1]. Cell components are redesigned and the capital cost of stack components will be largely reduced by the use of non-precious metal coatings [2].

In this work we investigate the corrosion resistance of niobium coatings on copper. Niobium coatings on copper substrate have been prepared by vacuum plasma spraying (VPS). Corrosion testing of niobium coatings was carried out in a three-electrode configuration cell in O<sub>2</sub> saturated 0.05 M and 0.005 M H<sub>2</sub>SO<sub>4</sub> solution at high temperature, 90°C, to simulate the PEMEL environment under operating conditions and in the presence of 0.1 ppm fluoride ions to simulate conditions due to the proton exchange membrane degradation by fluoride emission. Corrosion parameters have been determined before and after a long term stress test at constant potential of 2 V for 6 hours. All samples showed corrosion rates below 1 μm year<sup>-1</sup> and corrosion currents below 0.1 μA cm<sup>-2</sup>, which comply with the target of 0,1 μA cm<sup>-2</sup> by 2020 set by the US Department of Energy.

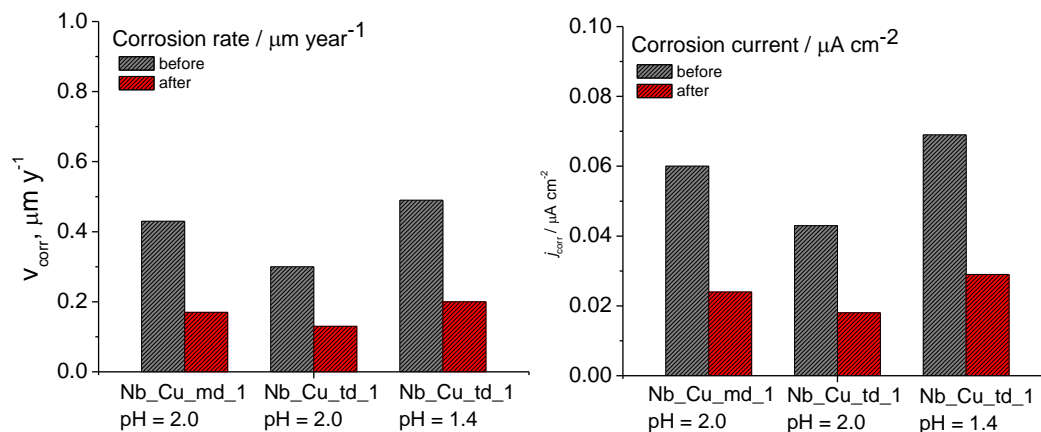

Figure 1. Determined values of corrosion currents and corrosion rates for VPS niobium coatings on copper.

The structure and morphology of the niobium coatings has been observed by field emission scanning electron microscopy before and after corrosion testing. The surface and cross-section images of the samples show no apparent damage of the coatings, nor the formation of pinholes beneath the niobium coating are detected.

**Acknowledgment:** PRETZEL project has received funding from the Fuel Cell and Hydrogen 2 Joint Undertaking under the European Union's Horizon 2020 research and innovation programme under grant agreement No 779478.

### References

1. M. Brodmann, M. Greda, C. Mutascu, J. Neumann, U. Rost, J. Roth, A. Wildometz, Method and system for operating an electrolyser, 2014, WO 2014040746A1 (patent pending).
2. A.S. Gago, S.A. Ansar, B. Saruhan, U. Schulz, P. Lettenmeier, N.A. Cañas, P. Gazdzicki, T. Morawietz, R. Hiesgen, J. Arnold, K.A. Friedrich, J. *Power Sources* **307** (2016) 815–825.

## Efficiency testing of commercial corrosion inhibitor for stainless steel EN 1.4301 and copper EN 13601 in simulated cooling water

Borislav N. Malinović, Duško Zorić<sup>1</sup>, Tijana Đuričić

University of Banja Luka, Faculty of Technology, Banja Luka, Bosnia and Herzegovina

<sup>1</sup>EFT Mine and Thermal Power Plant Stanari Ltd., Stanari, Bosnia and Herzegovina

For cooling purposes in the industry large amount of water are consumed. Open recirculation cooling systems has the wider application for the cooling in industry and energetics. One of the main problems of these cooling systems is corrosion. The main causes of corrosion in these systems are: pH, dissolved gases, ammonia, temperature and microbiology. Which physical-chemical parameters will be maintained, depends on construction material of system. In this paper it was examined the efficiency of the multicomponent commercial corrosion inhibitor which consist of  $H_2SO_4$ ,  $ZnCl_2$ ,  $C_7H_{11}O_9P$ ,  $C_2H_8O_7P_2$  [1]. For the purposes of research, the pilot plant of open recirculation cooling system is constructed (figure), modeled on a real industrial plant. The pilot plant is made of stainless steel EN 1.4301 and copper EN 13601. All experiments were performed in a simulated cooling water. In the first part of the research the effect of adding inhibitor on the quality parameters of cooling water was monitored. The simulated cooling water recirculated for 3.5h, and for the purpose of accelerating corrosion processes, it was added a corrosion activator, 5% aqueous sodium chloride solution. The second part of the research consists of determining the corrosion rate of the mentioned materials in the cooling water with the corrosion activator, without adding and with the adding of inhibitor. The corrosion rate is determined by using corrosion coupons according standard ASTM D2688 [2]. The results showed that the addition of inhibitor reduces the corrosion rate for both materials. It was achieved 67.1% protection efficiency for stainless steel and 72.8% in the case of copper.

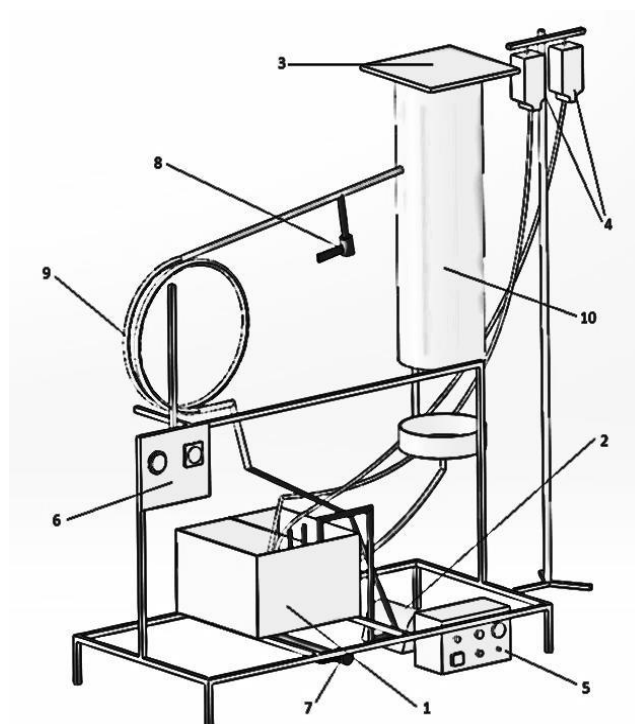

Pilot plant - 3D model of open recirculation cooling system: 1. Trunk with thermostat and heater, 2. Peristaltic pump, 3. Fan, 4. Dosing system for ammonia and sodium hypochlorite, 5. Control console for the pump, 6. Fan and heater control console, 7. Valve drain 8. Sampling valve, 9. Copper tube heat exchanger and 10. Cooling tower

### References

1. Kurita Europe GmbH. (2013). Safety Data Sheet KURITA S-6300. Viersen.
2. Standard Test Methods for Corrosivity of water in the Absence of Heat Transfer, ASTM D2688. (1999).

## Silica/graphene oxide composite coatings for corrosion protection of zinc

Tamara-Rita Ovari<sup>1</sup>, Gabriella Szabo<sup>1</sup>, Gabriel Katona<sup>2</sup>, Liana Maria Muresan<sup>1</sup>

*Babes Bolyai University, Faculty of Chemistry and Chemical Engineering*

*Department of Chemical Engineering, <sup>2</sup>Department of Chemistry, Cluj-Napoca, Romania*

[limur@chem.ubbcluj.ro](mailto:limur@chem.ubbcluj.ro)

Silica (SiO<sub>2</sub>) /graphene oxide (GO) nanocomposite coatings were prepared by dip-coating technique on zinc aiming to enhance its corrosion protective properties.

After optimization of several parameters such as bath composition, drying temperature, drying duration etc., the corrosion resistance of the coatings was evaluated mainly by means of electrochemical methods (electrochemical impedance spectroscopy and potentiodynamic polarization). Results have shown to be very promising and led to the conclusion that the composite of SiO<sub>2</sub>/GO coatings have better protection properties than simple silica-based coatings.

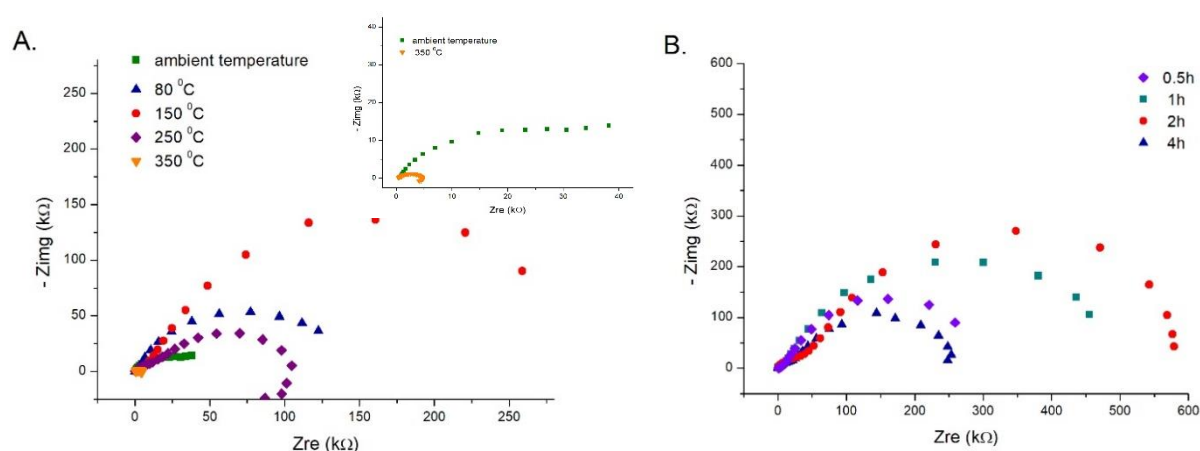

Figure 1: Nyquist impedance spectra of compact SiO<sub>2</sub> layers on zinc substrate dried at different temperatures (A) and prepared at the optimized temperature with different drying duration (B)

### References

1. S. Dalbin, G. Maurin, R. P. Nogueira, J. Persello, N. Pommier, *Surf. Coat. Tech.* **194** (2005) 363-371 (<https://doi.org/10.1016/j.surfcoat.2004.07.126>)
2. N. Cotolan, S. Varvara, E. Albert, G. Szabó, Z. Hórvölgyi & L.-M. Mureşan, *Corros. Eng. Sci. Techn.* **5** (2016) 373-382 (<https://doi.org/10.1080/1478422X.2015.1120404>)

## Formation and stability of protective films of phosphonic acid on various metal substrates

Dajana Mikić, Mia Gotovuša, Andreja Kišić, Helena Otmačić Ćurković  
Faculty of Chemical Engineering and Technology, University of Zagreb  
[dmikic@fkit.hr](mailto:dmikic@fkit.hr)

Corrosion is a natural phenomenon that causes great economic and environmental losses. Although many corrosion protection systems are present on the market, there is still a great need for environmentally and economically acceptable protective solutions. One of the possible solutions is application of thin, well-ordered films of long-chain organic acids called Self-Assembled Monolayers (SAMs).

Self-Assembled Monolayers are increasingly applied in microelectronics, sensors and electrocatalysis, but they also have a great potential in corrosion protection due to their unique properties. The organic molecules capable for forming SAMs consists of three parts - two functional groups and alkyl chain linking them. One of the functional groups is responsible for adsorption on the metal surface and is called the adhesion group or head of a molecule. The other functional group determines the layer properties and long alkyl chain represent the barrier to the diffusion of aggressive ions to the metal surface. The advantages of SAMs are simplicity of application, low cost and small amount of material needed to cover large areas.

The aim of this work is to obtain deeper insight into SAM properties by monitoring the process of forming octadecylphosphonic acid (ODPA) protective film on various metal substrates (gold, copper and stainless steel) using electrochemical quartz crystal microbalance (EQCM), followed by investigation of their behaviour in corrosive media by simultaneous use of EQCM and electrochemical impedance spectroscopy.

### References

1. E. Kristan Mioč, Z. Hajdari Gretić, H. Otmačić Ćurković, *Corrosion Science* **134** (2018) 189-198

## Corrosion protection of tin by some carboxylic acids in sodium chloride solution

Ivana Škugor Rončević<sup>1</sup>, Nives Vladislavić<sup>1</sup>, Marijo Buzuk<sup>1</sup>, Maša Buljac<sup>2</sup>, Anđela Lukin<sup>3</sup>

<sup>1</sup>*Department of General and Inorganic Chemistry, Faculty of Chemistry and Technology, University of Split, Croatia*

<sup>2</sup>*Department of Environmental Chemistry, Faculty of Chemistry and Technology, University of Split, Croatia*

<sup>3</sup>*Faculty of Chemistry and Technology, University of Split, Croatia*

[skugor@ktf-split.hr](mailto:skugor@ktf-split.hr)

Tin is a moderately corrosion resistant material that is widely used in tinfoil for food beverage. However, despite its excellent corrosion resistance, presence of oxidizing agents enhances the tin dissolution process by direct chemical attack. Dissolution of metallic tin, especially from the inside of a can body into the food content has a major influence on the food quality and may cause toxicological effects. To overcome the corrosion problem, different chemical compounds are added to the aggressive solutions. The most utilized inhibitors in food industry are nitrites and nitrates which are well-known hazardous to health. The aim of the present study was to investigate the influence of carboxylic acids (palmitic and stearic) on the corrosion resistance of tin, since they are present in fruit juices and different foodstuffs. The corrosion protection efficiency of the carboxylate coatings was investigated in a sodium chloride solution using electrochemical and spectroscopic techniques. The structural characteristics of the surface coatings were investigated using the FTIR spectroscopy and optical microscope.

## The synergistic inhibition of Vitamin E and K<sub>3</sub> in hydrophobic coatings on copper

Regina Fuchs-Godec

Faculty of Chemistry and Chemical Engineering, University of Maribor, Slovenia, regina.fuchs@um.si

Copper has a long history of a usage within many applications (industrial equipment, building construction, electricity and electronics, coinage and ornamental parts, etc.). Despite excellent corrosive resistance within many environments copper corrodes under certain circumstances. In order to preserve metal works from atmospheric corrosion or corrosion within aggressive media, suitable treatments with coating substances are often required. Development of a new generation of anticorrosion coatings possessing both passive matrix functionality and active response to change the characteristic of the local environment has upraised interest within material science during the past few years. [1-4]

The presented study is actually an extension of our previous work [3] in which we have investigated the stability and effectiveness of the as-prepared hydrophobic layer on the copper and copper alloys in simulated solution of urban acid rain (pH = 5) at 25 °C. The etched sheets were immersed within 0.05 M ethanolic solution of stearic acid SA (CH<sub>3</sub>(CH<sub>2</sub>)<sub>16</sub>COOH) with, and without the additions of various concentrations of Vitamin E or a Vitamin K<sub>3</sub> at room temperature, for about one hour to form the self-assembled layer. Obtainable results regarding to the inhibition efficiency were fascinated, therefore it was natural to extend these studies. Several studies have suggested that inhibition efficiency could be improved by using mixtures of inhibitors with respect to a single inhibitor. In this presented case a fat-soluble Vitamin E and Vitamin K<sub>3</sub> were used as a type of green inhibitors separately and in the case as mixture including both of them. Potentiodynamic polarisation and electrochemical impedance spectroscopy techniques were performed in order to examine the acid corrosion-inhibition process of the chosen system. Scanning electron microscope (SEM) was used to characterise the morphologies of the surfaces of the self-assembled layers.

The inhibitive effectiveness of copper reached 94 % in those cases when the surface was modified in stearic acid alone, whereas the values with addition of Vitamin E or K<sub>3</sub> or in the case of mixture including both of them increased to more than 99.0%.

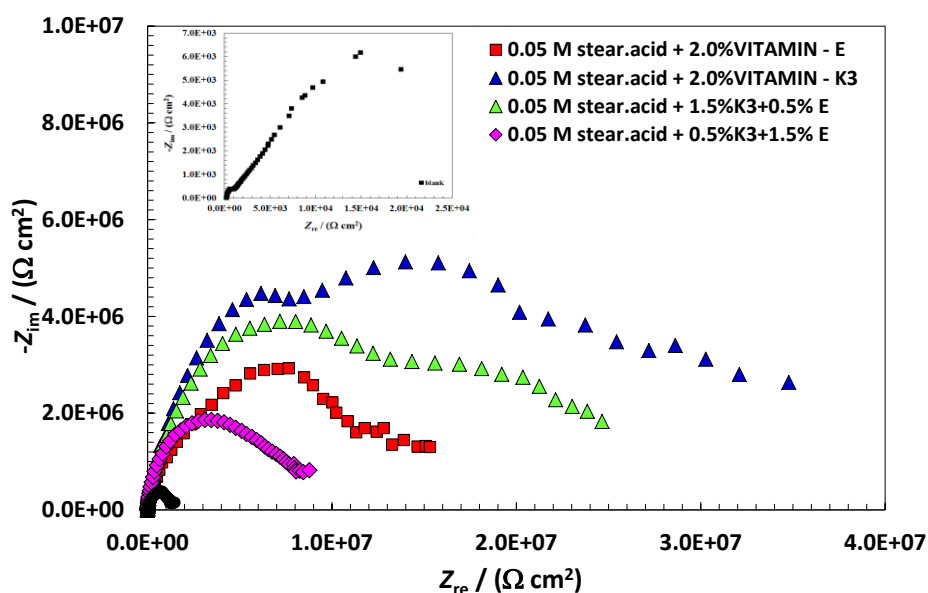

### References:

1. H. Yu, C. Li, B. Yuan, L. Li, C. Wang, *Corros. Sci.*, 120 (2017) 231-238, <https://doi.org/10.1016/j.corsci.2017.03.006>.
2. P. Wang, D. Zhang, R. Qiu, Y. Wan, J. Wu, *Corros. Sci.*, 80 (2014) 336-373, <https://doi.org/10.1016/j.corsci.2013.11.055>.
3. R. Fuchs-Godec, G. Zerjav, *Corros. Sci.*, 97 (2015) 7-16, <https://doi.org/10.1016/j.corsci.2015.03.016>.
4. C. Verma, E. E. Ebenso, M. A. Quraishi, *J. Mol. Liq.*, 233 (2017) 403-414, <https://doi.org/10.1016/j.molliq.2017.02.111>.

## Corrosive wear degradation of Ti-based implant alloy

Ivana Cvijović-Alagić<sup>1</sup>, Zorica Cvijović<sup>2</sup>, Jelena Bajat<sup>2</sup>, Marko Rakin<sup>2</sup>

<sup>1</sup>*Institute of Nuclear Sciences "Vinča", University of Belgrade, Mike Petrovića Alasa 12-14, Belgrade, Serbia,*

<sup>2</sup>*Faculty of Technology and Metallurgy, University of Belgrade, Karnegijeva 4, 11120 Belgrade, Serbia*  
[ivanac@vinca.rs](mailto:ivanac@vinca.rs)

Titanium-based alloys are widely used for orthopaedic and dental implants manufacture since these materials are highly biocompatible and show excellent mechanical characteristics along with better corrosion resistance compared with other metallic implant materials. The Ti-6Al-4V ELI (mass%) alloy is the most commonly used bio-metallic material for artificial joints and dental implants production and improvement of its characteristics in a cost-effective way could lead to the future production of more durable implants without the need of investing in the novel implant materials development and long-term investigations. Since all hard-tissue implants are exposed to highly corrosive environment accompanied by tribologically demanding conditions, improvement of the implant materials tribo-corrosion properties is, therefore, high-priority demand when metallic implant materials are concerned. Corrosive wear degradation of the implant materials in the physiological body conditions should be extensively reduced simultaneously with maintaining desirable material characteristics.

The aim of the presented study was to investigate the possible Ti-6Al-4V ELI alloy tribo-corrosion properties improvement by the alloy microstructural modification. Wear and corrosion behaviour of Ti-6Al-4V ELI alloy in four different microstructural conditions were studied at room temperature in a Ringer's solution. The as-received alloy was subjected to solution treatment in the  $\beta$  and  $(\alpha+\beta)$  phase field and afterwards, furnace cooled down in order to obtain lamellar and equiaxed microstructure, or water quenched for martensitic and globular microstructure obtainment, respectively. The reciprocating sliding wear behaviour was examined by applying a normal load of 100, 500 and 1000 mN and sliding speed of 4 mm/s with particular emphasis on the damage mechanisms identification during frictional sliding. The corrosion behaviour was studied using potentiodynamic polarization test.

Obtained results indicated that Ti-6Al-4V ELI alloy wear occurs as a consequence of the complex damage mechanism which involves abrasive, adhesive and corrosive wear. Corrosive wear is predominant wear mechanism in the alloy with martensitic and globular microstructure, adhesion predominates in the case of equiaxed and lamellar microstructure, while abrasion predominates in the complex damage mechanism during sliding under lower nominal loading conditions (see Figure 1). Investigated alloy passivates in the presence of the Ringer's solution and on the alloy surface two-layered passive films with good protective characteristics can be recognized. Formation of the inner barrier layer composed of  $\text{TiO}_2$  oxide particles improves Ti-6Al-4V ELI alloy corrosion resistance especially when the alloy is in acicular (*i.e.* lamellar and martensitic) microstructural condition.

Conducted tribo-corrosion investigations indicated that the best combination of corrosion and wear properties shows Ti-6Al-4V ELI alloy with acicular microstructure obtained by solution treatment in the  $\beta$  phase field. Moreover, obtained results confirmed that cost-effective solution treatment could lead to the significant improvement of the most commonly used implant alloy corrosion wear characteristics and in that way influence the improvement of orthopaedic and dental implants durability.

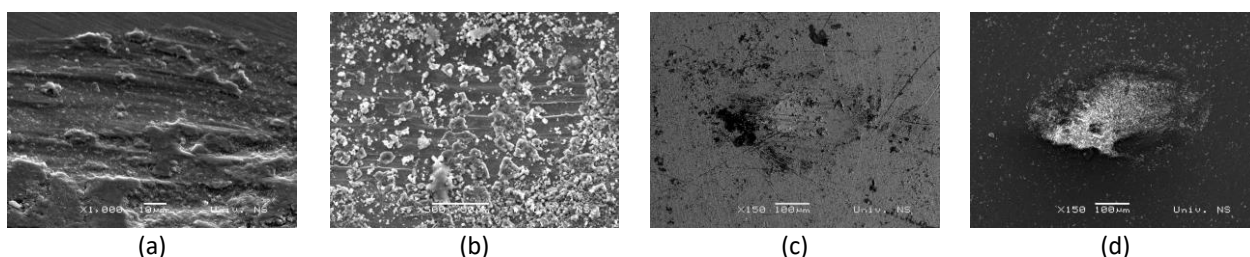

Figure 1. SEM micrographs showing wear damage after linear reciprocal-sliding in Ringer's solution under normal load of 500 mN and sliding speed of 4 mm/s detected on the surface of Ti-6Al-4V ELI alloy with (a) lamellar, (b) martensitic, (c) equiaxed and (d) globular microstructure

## Surface modification of Ti dental implant by bioactive coatings: experimental and theoretical studies

Jozefina Katić<sup>1</sup>, Ankica Šarić<sup>2</sup>, Ines Despotović<sup>2</sup>, Marin Petković<sup>3</sup>, Katarina Varžić<sup>1</sup>, Mirela Leskovic<sup>1</sup>,  
Željka Petrović<sup>2</sup>

<sup>1</sup>University of Zagreb, Faculty of Chemical Engineering and Technology,  
Marulićev trg 19, 10000 Zagreb, Croatia

<sup>2</sup>Ruđer Bošković Institute, Bijenička c. 54, 10002 Zagreb, Croatia

<sup>3</sup>Adentro Dental Studio, Petrova 67, 10000 Zagreb, Croatia

[jkatic@fkit.hr](mailto:jkatic@fkit.hr); [zpetrov@irb.hr](mailto:zpetrov@irb.hr)

Life inevitably leaves its traces on the teeth. A mechanical trauma, an accident or untimely treated caries and periodontitis frequently lead to permanent tooth loss. Dentists and dental specialists have a contemporary solution: the small titanium body fixed into the jawbone acts as the base for single crowns, larger bridges or dentures. Titanium dental implants, in the form of screw (*endosseous* implants), are various-age appropriate secure solution and are the most used implants.<sup>1</sup>

Since a dental implant, generally metal-made, represents a foreign body for the patient, many difficulties can occur. Therefore, for successful implant application, the dental industry has to consider all relevant factors that are related to dental reconstruction and restoration like biocompatibility, osseointegration, corrosion resistance, implant geometry design, mechanical stability, and implant/bone and implant/surrounding tissue interactions.<sup>2</sup>

Once the implant is placed within the jaw, it should rapidly osseointegrate with surrounding bones and tissues and create a stable implant/surrounding bone interface. It is clear, implant-bone and implant-surrounding tissue interactions are affected by the implant surface microstructure, composition, morphology, roughness and hydrophilicity. Hence, surface engineering plays a significant role in the improvement of the implantation process, especially osseointegration. Many studies report about surface modification of dental implants (*e.g.*, sandblasting, acid etching, anodization, self-assembling etc.) in order to optimize and improve their surface characteristics and enhance implantation.<sup>3</sup>

In this study, the titanium implant surface was functionalized by chemisorption of osseoinductive molecule using a facile and effective approach. The morphology of the modified implant surface, Ti/TiO<sub>2</sub>/bioactive coating, was examined by SEM and wetting properties by contact angle measurements. Electrochemical properties of the Ti/TiO<sub>2</sub>/bioactive coating were studied *in vitro* in artificial saliva solution using electrochemical impedance spectroscopy. The experimental findings were corroborated by means of DFT calculations. The formation mechanism of bioactive implant coating was proposed considering experimental results and a computational study of Gibbs free energies of bioactive molecule/TiO<sub>2</sub> molecular interactions ( $\Delta G^*_{\text{INT}}$ ).

### References

1. <https://implants.dentsplysirona.com/en/implant-systems.html>
2. M. Manjaiah, R.F. Laubscher, *Materials and Technology* **51** (2017) 181
3. L. Rojo, B. Gharibi, R. McLister, B. J. Meenan, S. Deb, *Scientific Reports* **6** (2016) 30548

# **Electroanalytical Chemistry and Sensors**

### **Electrochemical-biosensor for the detection of coliform presence in drinking water**

Teri Bigham<sup>1,2</sup>, Charnete Casimero<sup>1</sup>, James Dooley<sup>2</sup>, Nigel Ternan<sup>2</sup>, William Snelling<sup>2</sup>, James Davis<sup>1</sup>

<sup>1</sup>*Nanotechnology and Integrated Bioengineering Centre, School of Engineering, Ulster University, Jordanstown, Northern Ireland, BT37 0QB*

<sup>2</sup>*Microbiology, Nutrition Innovation Centre for food and Health (NICHE), School of Biomedical Sciences, Ulster University, Coleraine, Northern Ireland, BT52 1SA*

It is well established that drinking water contaminated with faecal matter poses a series risk of waterborne disease yet, it is estimated that almost 2 million people are reliant on such sources. The production of improved water sources for low- and middle-income countries has been a long-standing international commitment but ensuring that the drinking water is safe to drink remains a challenge – particularly in rural communities. The development of low-cost diagnostic systems capable of detecting coliform contamination is clearly required. The design of a disposable microfluidic based device that integrates the preconcentration, culture and detection of *E. coli* is presented as a possible solution. The device is based on a thin layer conductive carbon fibre filter modified with a riboflavin – ferrocyanide redox couple. The device utilises the fermentation characteristics of captured indicator bacteria to lower the local pH by the production of lactic acid and pyruvate after the introduction of lactose. The process can be monitored voltammetrically whereby ferrocyanide (internal reference) and riboflavin (pH probe) are readily detectable at the carbon fibre filter and demonstrates the indirect measure of the change in pH as a function of time and bacterial concentration. The construction of the device and the electroanalytical responses are presented and the analytical efficacy, in terms of bacterial detection and in relation to present WHO criteria, is critically evaluated wherein it has been shown an ability in the detection of coliforms to a suitable degree.

## Electrochemical, zeta-potential and particle size characterization of groundwater samples

Žana Kajinić<sup>1</sup>, Jelena Vešligaj Turkalj<sup>2</sup>, Željka Romić<sup>2</sup>, Anamarija Stanković<sup>1</sup>, Maja Dutour Sikirić<sup>3</sup>,  
Martina Medvidović-Kosanović<sup>1</sup>

<sup>1</sup>*Department of Chemistry, University of Osijek, Ulica cara Hadrijana 8A, HR-31000 Osijek, Croatia*

<sup>2</sup>*Vodovod, Poljski put 1, HR-31000 Osijek, Croatia*

<sup>3</sup>*Ruđer Bošković Institute, Bijenička ulica 54, HR-10000 Zagreb, Croatia*

[mmkosano@kemija.unios.hr](mailto:mmkosano@kemija.unios.hr)

Water is the most important chemical compound on earth essential for all living organisms. Natural and industrial waters contain different ions and particles ranging in sizes from nanometers to micrometers. The ionic and particle composition as well as their amount determines their potential application and treatment methods. Drinking water is clear, has no smell or colour and for the good taste should contain diluted oxygen, carbon dioxide and soluble salts (NaCl, NaHCO<sub>3</sub>) [1]. Groundwater contains arsenic in a form of arsenite and arsenate, which if consumed have toxic effects on humans, animals and the entire ecosystem. Millions of people from different countries (Chile, Mexico, China, Argentina, USA, Hungary, Indian State of West Bengal, Bangladesh, and Vietnam) heavily depend on groundwater which contains elevated level of arsenic for drinking purposes. Long term consumption of such water (such as 5-10 years) may cause arsenicosis, which is arsenic related health problem [2]. The main goal of our study was to detect more toxic trivalent arsenite (As<sup>III</sup>) in groundwater samples from Osijek region and to determine zeta potential values and particle size of the same samples.

Electrochemical measurements were conducted in a three electrode voltammetric cell in a phosphate buffer at pH 7, where modified glassy carbon electrode was used as a working electrode, Ag/AgCl as a reference electrode and a platinum wire as a counter electrode [3]. The system was purged with high purity argon, Ar5 ( $\phi_{Ar} = 99.999\%$ ) before each measurement. Dynamic and electrophoretic light scattering measurements were performed in order to determine zeta potential and size distribution of particles present in the sample.

Arsenite was first detected in the model systems with differential pulse voltammetry where linear response was obtained in a concentration range from 2.0  $\mu\text{mol dm}^{-3}$  to 22.0  $\mu\text{mol dm}^{-3}$ . Then the groundwater samples were studied and the obtained arsenite concentration varied between 2.5  $\mu\text{mol dm}^{-3}$  to 3.5  $\mu\text{mol dm}^{-3}$ . Zeta potential measurements showed that particles in all groundwater samples have negative zeta potential (it varied from -2 mV to -13 mV) even though small amounts ( $x \sim 3\%$ ) of particles with positive zeta potential values were also detected in two samples. Particle size measurements revealed monomodal, bimodal and trimodal particle size distributions while the most common particle size in all samples was in a nm range (it varied from 393 nm to 808 nm).

### References

1. D. Brozović, A. Kovačec, Hrvatska enciklopedija, on-line izdanje, Leksikografski zavod Miroslav Krleža (<http://www.enciklopedija.hr/natuknica.aspx?ID=65109>) 02.01.2019.
2. S. Shankar, U. Shankar, Shikha, *The Scientific World Journal* **2014** (2014) 1. (<http://dx.doi.org/10.1155/2014/304524>)
3. M. Rajkumar, S. Thiagarajan, S.-M. Chen, *International Journal of Electrochemical Science* **6** (2011) 3164.

## Electrochemical determination of nitric oxide in human macrophage

Valentina Popova<sup>1</sup>, Elena Korotkova<sup>1</sup>, Jiri Barek<sup>2</sup>

<sup>1</sup>National Research Tomsk Polytechnic University, 30 Lenin Avenue, 634050, Tomsk, Russia

<sup>2</sup>Charles University, Faculty of Science, Department of Analytical Chemistry, UNESCO Laboratory of Environmental Electrochemistry, Albertov 6, 12843 Prague 2, Czech Republic  
[vap25@tpu.ru](mailto:vap25@tpu.ru)

Macrophages play a crucial role in the development of inflammation. They can acquire a proinflammatory or anti-inflammatory phenotype, depending on the tumor microenvironment. The phenotype of tissue macrophages may change under the action of certain signals produced by the tumor microenvironment. This leads to the formation of macrophages associated with the tumor [1]. In that case, macrophages associated with a tumor are divided [2]: in a tumor, both M1 and M2-polarized types [3]. Macrophage population, associated with a tumor and polarized by M1 type, suppresses tumor development, whereas M2 promote it [4]. Consequently, it can be assumed that by manipulating phenotype of the macrophages associated with the tumor, its treatment can be improved.

The functional marker of the formation of macrophages M1 is enhanced production of NO. Therefore, the assessment of NO produced by macrophages can be a significant marker of macrophage reprogramming during therapeutic manipulations. Quantitative determination of the NO directly in biological objects requires the development of sensitive and selective technique. Electrochemical method is one of the most suitable among analytical approaches for monitoring NO. The purpose of this work is quantitative determination of NO by voltammetry, as a reprogramming marker of macrophages associated with a tumor in the supercellular fluids of macrophages on the modified electrode.

All measurements were carried out using analyzer TA-2 (Tomsk, Russia). The three-electrode electrochemical cell was equipped with the graphite electrode, modified by carbon inc and nafion (MGE) as the working electrode, Ag/AgCl/(saturated KCl) as the reference and counter electrodes. The object of the study was the supercellular fluid of macrophages, where the type of polarization (M1 or M2) by adding lipopolysaccharides (LPS) or interleukin-4 (IL 4), respectively, was changed. Supernatants of macrophage were preliminary prepared, including purification from the protein fraction. To remove interfering influence of nitrite ions, the electrode surface was modified with anion-exchange polymer — Nafion.

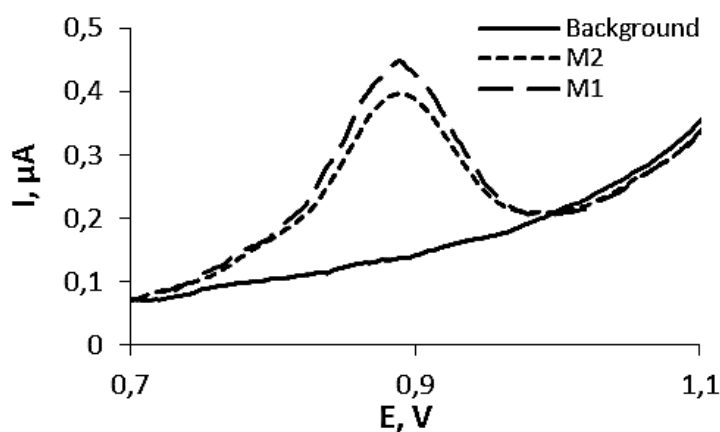

Figure 1. Anodic voltammograms of NO on MGE in samples of macrophages with M1 and M2 polarization

Voltammograms of NO oxidation were obtained on a modified electrode with preliminary accumulation at 0.4 V,  $t_e = 4$  s,  $W = 100$  mV s<sup>-1</sup>. The peak of oxidation of NO was recorded at the potential of 0.89 V (Figure 1). As can be seen from the figure 1, in macrophages of type M1, NO content is higher than in macrophages with M2 polarization. This approach will allow the assessment of the NO content in biological objects, which is an important marker of macrophage reprogramming that occurs during therapeutic manipulations.

### References

1. F.T. Chung, K.Y. Lee, C.W. Wang, *Int. J. Cancer* **131** (2012) 227-235 (<https://dx.doi.org/10.1002/ijc.27403>)
2. D.M. Mosser, J.P. Edwards, *Nat Rev Immunol.* **8** (2008) 958-969 (<https://dx.doi.org/10.1038/nri2788>)
3. M. Takeya, Y. Komohara, *Pathol Int.* **66** (2016) 491-505 (<https://dx.doi.org/10.1111/pin.12440>)
4. S.A. Almatroodi, I. A. Darby, *Cancer Microenviron* **9** (2016) 1-11 (<https://dx.doi.org/10.1007/s12307-015-0174-x>)

## Sequential analysis of Pb(II) traces using unmodified and modified SPE electrodes

Matjaž Finšgar<sup>1</sup>, David Majer<sup>1</sup>, Uroš Maver<sup>2</sup>, Tina Maver<sup>3</sup>

<sup>1</sup>Faculty of Chemistry and Chemical Engineering, University of Maribor, Smetanova ulica 17, 2000 Maribor, Slovenia

<sup>2</sup>Faculty of Medicine, Institute of Biomedical Sciences, University of Maribor, Taborska ulica 8, SI-2000 Maribor, Slovenia

<sup>3</sup>Faculty of Mechanical Engineering, University of Maribor, Smetanova ulica 17, 2000 Maribor, Slovenia  
[matjaz.finsgar@um.si](mailto:matjaz.finsgar@um.si)

Reusability of the Sb-film modified screen printed electrode (SPE) and unmodified SPE electrode was studied. The same sensor was used several times in sequence to analyse Pb(II) traces in 0.01 M HCl with anodic stripping voltammetry. In the case of the Sb-film modified sensor, accuracy and precision was satisfactory (RSD < 20%, recovery within 80–120%) when the sensor was used for the first time, whereas subsequent analyses reported lower accuracy and precision. On the other hand, unmodified SPE showed an opposite trend, where analytical performance became better when the sensor was used multiple times indicating the need for pre-activation. The degradation of the sensor was also studied with the electrochemical impedance spectroscopy, atomic force microscopy, and scanning electron microscopy. Interference effect was checked for Cd(II), Zn(II), Fe(II), Na(I), As(III), K(I), Ca(II), Mg(II), Bi(III), Cu(II), Sn(II), Hg(II), and NO<sub>3</sub><sup>-</sup>. Finally, the applicability of the modified SPE was proven with regard to a real water sample.

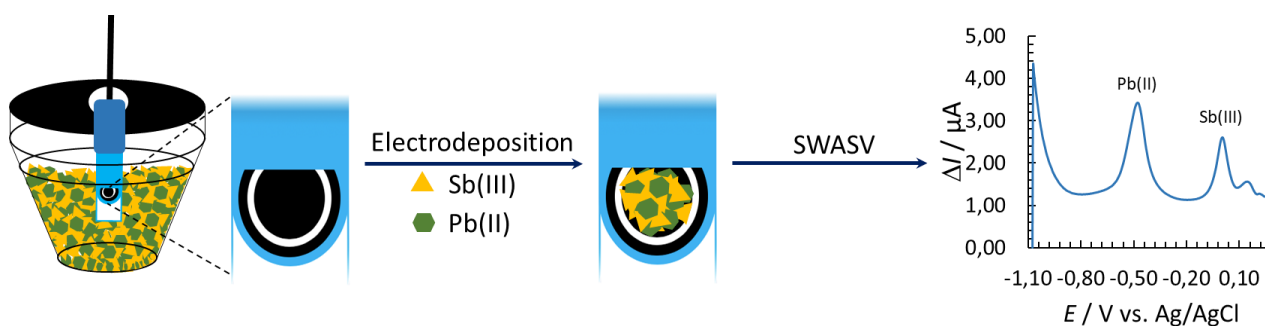

Figure: Accumulation and measurement procedure

### References

1. M. Finšgar, D. Majer, U. Maver, T. Maver, *Sensors* **18** (2018) 1-16

## Analytical applications of new chemically modified electrodes based on crown ether for heavy metal analysis

Alexandru Anton Ivanov<sup>1,2</sup>, Elena Diacu<sup>1</sup>, Eleonora-Mihaela Ungureanu<sup>1</sup>, Sabina-Vasilica Pistol<sup>1</sup>,  
Adinuta Paun<sup>1</sup>, Magdalena-Rodica Bujduveanu<sup>1</sup>

<sup>1</sup>University "Politehnica" of Bucharest, Faculty of Applied Chemistry and Materials Science,  
Gheorghe Polizu 1-7, 011061 Bucharest, Romania

<sup>2</sup>National Institute for Research and Development in Environmental Protection,  
Splaiul Independentei 294, 060031 Bucharest, Romania

New materials based on 12-crown-4-eter-vinyl azulene have been used to obtain heavy metal complexing modified electrodes with potential applications in environment monitoring. The new compound 4'-(E-azulen-1-il-vinyl)-12-crown-4-eter (**L**) has been synthesized and characterized to study its electrochemical properties by voltammetric techniques such as cyclic voltammetry (CV), differential pulse voltammetry (DPV) and rotating disk electrode (RDE) voltammetry. Distinct anodic and cathodic peaks were identified in all voltammetric curves. Poly**L** modified electrodes were obtained by electro-polymerization on glassy carbon electrode using controlled potential electrolysis. The detection of heavy metal ions has been performed using the prepared modified electrodes. Good results have been obtained for Hg(II), Pb(II), Cu(II) and Cd(II) ions determination, the best limit of detection ( $10^{-7}$  M) has been achieved in the case of mercury and lead ions. Poly**L** modified electrodes were used for the electro-analysis of Hg(II) and Pb(II) ions in tap waters, the results being validated by CV-AAS and respectively GF-AAS methods.

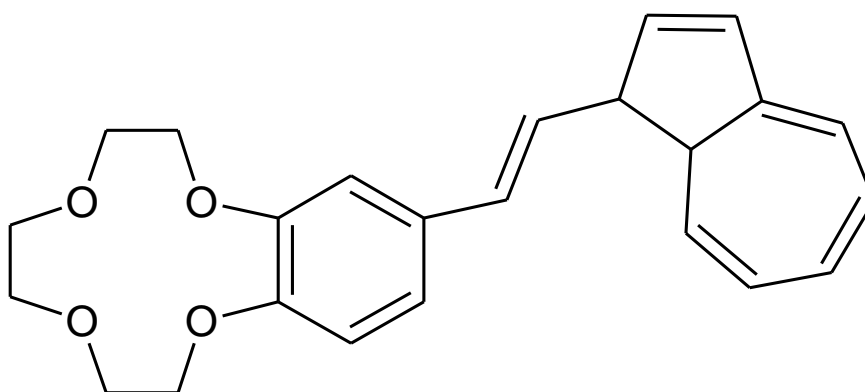

4'-(E-azulen-1-il-vinyl)-12-crown-4-eter (**L**)

### References

1. G.-O. Buica, I.-G. Lazar, E. Saint-Aman, V. Tecuceanu, C. Dumitriu, A.A. Ivanov, A.B. Stoian, E.-M. Ungureanu, *Sensors and Actuators B*, vol. 246, 2017, pp. 434–443 (<https://doi.org/10.1016/j.snb.2017.02.112>).
2. I.-G. Lazar, E. Diacu, G.-O. Buica, E.-M. Ungureanu, G.-L. Arnold, L. Birzan, *Revista de Chimie*, 68, 11, 2017, pp. 2509–2513.
3. G.-O. Buica, I.-G. Lazar, L. Birzan, C. Lete, M. Prodana, M. Enachescu, V. Tecuceanu, A. B. Stoian, E.-M. Ungureanu, *Electrochimica Acta*, 263, 2018, 382-390.

## Modified electrodes with thiosemicarbazone receptors for metal ions complexation

George-Octavian Buica, Matei D. Raicopol, Nicoleta A. Chira

<sup>1</sup>University "Politehnica" of Bucharest, Gheorghe Polizu 1-7, 011061, Sector1, Bucharest, Romania,  
[buica\\_george@yahoo.com](mailto:buica_george@yahoo.com)

The concept of "click chemistry" introduced by Sharpless and co. in 2001 [1] was undoubtedly one of the main approaches in contemporary chemistry, being considered the success story of synthetic chemistry. The "click" term refers to an efficient and selective chemical process leading to a single reaction product at the end of reaction. Also, being originally designed as a tool in organic synthesis, it emerged very rapid as one of the most employed methods for engineering the architecture and functions of different types of surfaces with important applications (*e.g.* nanomaterials) [2]. Moreover, this method can be applied in mild conditions, even in aqueous solvents, in the presence of a catalyst and of many functional groups without protection. The process is fast, selective and resistant to side reactions. However, this approach has seldom been applied to chemically modified electrodes (CMEs) for heavy metal ions detection.

Here, we report the chemical synthesis of new ligand based on thiosemicarbazone and its immobilization on electrode surface through a "click chemistry" protocol for obtaining modified electrodes. The complexing properties of CMEs towards metal ions were also investigated.

*Acknowledgements:* The authors gratefully acknowledge for the financial support of the Romanian National Authority for Scientific Research, UEFISCDI, under grant PN-III-P1-1.1-TE-2016-0860, contract no. 114/2018.

### References

1. H.C. Kolb, M.G. Finn, K.B. Sharpless, *Angew. Chem.*, **113** (2001) 2056–2075.
2. G.K. Such, A.P.R. Johnston, K. Liang, F. Caruso, *Prog. Polym. Sci.*, **37** (2012) 985 – 1003.

## Voltammetric determination of drug based on indomethacin menthyl ester

Olga Lipskikh<sup>1</sup>, Elena Korotkova<sup>1</sup>, Alena Nikolaeva<sup>1</sup>, Jiri Barek<sup>1,2</sup>

<sup>1</sup>National Research Tomsk Polytechnic University, School of Earth Sciences & Engineering, Division of Chemical Engineering, 30, Lenin Avenue, Tomsk, 634050, Russia

<sup>2</sup>Charles University, Faculty of Science, Department of Analytical Chemistry, UNESCO Laboratory of Environmental Electrochemistry, Hlavova 8/2030, CZ 128 43 Prague 2, Czech Republic  
[lipskikh-olga@yandex.ru](mailto:lipskikh-olga@yandex.ru)

Nowadays there is an urgent demand to create new dosage forms - the so-called prodrugs - that can turn into an active drug spontaneously or under the influence of enzymes [1]. A prodrug based on a new low-toxic molecule - a derivative of indole acetic acid (menthyl indomethacin ester) is an effective and safe substance used to treat arthritis and other inflammatory diseases. The studied molecule called indomenthyl (IML) has an empirical formula of  $C_{29}H_{34}ClNO_4$  and molecular weight 496.05 g/mol with structural formula presented at figure 1.

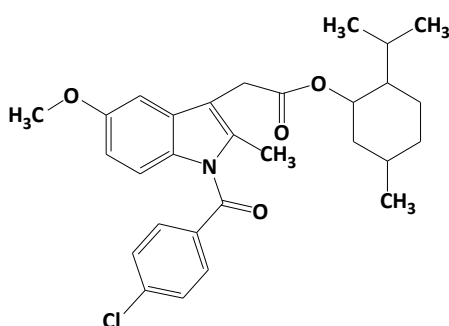
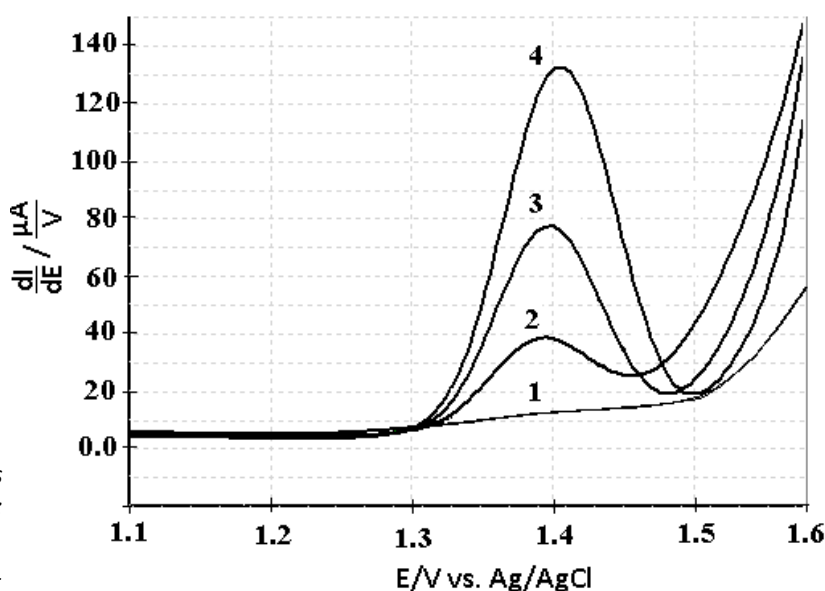

Figure 1. Structural formula of indomenthyl

Figure 2. LSVs of different concentrations of IML at GCE in 0.1M NaClO<sub>4</sub>:  
1 – supporting electrolyte,  
2 – 1·10<sup>-4</sup>M, 3 – 2·10<sup>-4</sup>M, 3 – 3·10<sup>-4</sup>M IML



Linear scan voltammetry (LSV) in differential mode was applied for IML determination in 0.1M NaClO<sub>4</sub> : ethanol solution at glassy carbon electrode (GCE). Silver-silver chloride electrode and Pt wire were used as reference and auxiliary electrodes. 0.01 M IML solution in dimethyl formamide was added to electrochemical cell and LSVs were obtained from 1.1 to 1.6 V. Figure 2 displays stable and well-defined oxidation peak whose intensity is increasing with IML concentration.

IML molecule consists of two moieties – indomethacin and menthol. Most likely oxidation peak is associated with indomethacin moiety electrochemical oxidation [2].

Different factors may affect on influence IML determination: electrode material, modifier, pH, scan rate, etc. Nevertheless, IML oxidizability provides a good opportunity for voltammetric technique development for its quantitative determination in different pharmaceutical substances and drugs.

### References

1. M. Markovic, S. Ben-Shabat, S. Keinan, et al., *Med Res Rev.*, 39 (2019) 579-607.  
<https://doi.org/10.1002/med.21533>
2. Y. Liu, Q. Huang, C. Zhang, C. Liang, L. Wei, J. Peng, *Int. J. Electrochem. Sci.*, 13 (2018) 1484 – 1494, doi: 10.20964/2018.02.39

## Voltammetric characterization and trace level determination of dopamine by carbon paste electrode surface modified with oxidized multiwalled carbon nanotubes

Jasmina Anojčić, Valéria Guzsvány, Zoltán Kónya<sup>1,2</sup>, Momir Mikov<sup>3</sup>

University of Novi Sad, Faculty of Sciences, Department of Chemistry, Biochemistry and Environmental Protection, Trg D. Obradovića 3, 21000 Novi Sad, Serbia

<sup>1</sup>University of Szeged, Department of Applied and Environmental Chemistry, Rerrich Béla tér 1, Ž6720 Szeged, Hungary

<sup>2</sup>MTA-SZTE Reaction Kinetics and Surface Chemistry Research Group, Rerrich Béla tér 1, 6720 Szeged, Hungary

<sup>3</sup>University of Novi Sad, Faculty of Medicine, Department of Pharmacology, Toxicology and Clinical Pharmacology, Hajduk Veljkova 3, 21000 Novi Sad, Serbia

[jasmina.anojcic@dh.uns.ac.rs](mailto:jasmina.anojcic@dh.uns.ac.rs)

Dopamine (DA) is the predominant catecholamine neurotransmitter in the mammalian brain which acts as biomarker to identify the certain diseases such as Parkinson's disease and schizophrenia [1,2]. Nowadays, many investigations are focused to development of reliable, precise and selective analytical methods for its determination at the low concentration levels in biological samples as well as for quality control of pharmaceutical formulations with DA as active ingredient. Since DA is highly electroactive molecule, electrochemical methods proved to be convenient tools for its determination, due to their numerous advantages including cost effectiveness, high sensitivity, simplicity and fast analytical response [1,3]. In this work, carbon paste electrode (CPE) was surface modified with homemade multiwalled carbon nanotubes in their native (MWCNTs) and chemically oxidized (ox-MWCNT/CPE) form by simply drop coating procedure to prepare sensitive and reliable working electrode for trace level voltammetric determination of DA. Synthesized nanomaterials were characterized in details by transmission electron microscopy, infrared and Raman spectroscopy. DA redox behavior at CPE and ox-MWCNT/CPE was studied by CV indicating that redox reaction is rather diffusion controlled in both cases. After optimization steps concerning the selection of working electrode, pH of supporting electrolyte and amount of CPE modifier, the ox-MWCNT/CPE in combination with direct square wave voltammetry (SWV) was employed for cathodic DA determination. At pH around 6 (0.1 M phosphate buffer solution), a linear response for DA was obtained in the concentration range of 16.15-192.70 ng mL<sup>-1</sup>, the relative standard deviation (RSD) did not exceed 1.3%, while achieved detection and quantitation limits in model solution were 4.89 ng mL<sup>-1</sup> and 16.15 ng mL<sup>-1</sup>, respectively. The developed SWV method was successfully applied for determination of DA in its pharmaceutical formulation *i.e.* DA hydrochloride injection sample, the obtained result for DA content was in a good agreement with the producer declared value, and RSD of the method was below 1.0%.

*Acknowledgements:* The authors acknowledge the financial support of the Ministry of Science and Technological Development of the Republic of Serbia (Project Nos. 172059 and 172012) and CEEPUSIII (CZ-0212-12-1819) network. GV thanks the Domus Hungarica Scientiarum et Artium fellowship.

### References

1. N. Baig, A. Rana, A.-N. Kawde, *Electroanalysis* **30** (2018) 2551. (<https://doi.org/10.1002/elan.201800468>)
2. M. Sajid, M.K. Nazal, M. Mansha, A. Alsharaa, S.M.S. Jillani, C. Basheer, *Trends in Analytical Chemistry* **76** (2016) 15. (<https://doi.org/10.1016/j.trac.2015.09.006>)
3. A. Azzouz, K.Y. Goud, N. Raza, E. Ballesteros, S.-E. Lee, J. Hong, A. Deep, K.-H. Kim, *Trends in Analytical Chemistry* **110** (2019) 15. (<https://doi.org/10.1016/j.trac.2018.08.002>)

## Adsorptive stripping voltammetric determination of fungicide carbendazim by tetrabutylammonium chloride modified carbon paste electrode

Sanja Šekuljica, Valéria Guzsvány, Kurt Kalcher<sup>1</sup>

University of Novi Sad, Faculty of Sciences, Department of Chemistry, Biochemistry and Environmental Protection, Trg Dositeja Obradovića 3, 21000 Novi Sad, Serbia

<sup>1</sup>Karl Franzens University, Institute of Chemistry-Analytical Chemistry, Universitaetsplatz 1, 8010 Graz, Austria

[sanja.sekuljica@dh.uns.ac.rs](mailto:sanja.sekuljica@dh.uns.ac.rs)

Nowadays, ionic liquid (IL) modified carbon paste electrodes (CPE) draw attention in analytical voltammetry as ILs serve as promising modifiers providing to advanced electrodes excellent performances by minimizing their capacitive current and enhancing the faradaic responses [1]. The quaternary ammonium cation based IL, tetrabutylammonium chloride (TBACl), is considered via this work as possible material for modification of graphite powder and paraffin oil containing CPE (TBACl-CPE) for trace level determination of a harmful electroactive analyte carbendazim (methyl-1H-benzimidazol-2-yl-carbamate, CBZ). This broad-spectrum fungicide could be found in the environment as contaminant due to its low solubility in water [2] and long-time persistence/slow degradation capability [3] thanks to its benzimidazolic ring which is difficult to break [4]. So, the ability to rapidly and accurately detect/determine of CBZ in different matrices is of public health and environmental protection significance and is a long-time challenge in analytical laboratories. Considering the physical and chemical properties of TBACl as a building element of TBACl-CPEs, it could exhibit favourable interactions with CBZ because of appropriate hydrophobicity. Herein, a TBACl-CPE was prepared and employed for the room temperature determination of CBZ in combination with square wave adsorptive stripping voltammetric (SW-AdSV) method in water media. As CBZ could be differently charged depending on the pH value of the supporting electrolyte due to stabilization of ionic forms by resonance after delocalization along the aromatic heterocyclic ring and the carbamate group [5], it is expected that CBZ is mainly positively charged at pH 5.0 [6]. Under optimal working conditions at -0.25 V and pH 5.0, the proposed electrode exhibits significant affinity towards target analyte. The SW-AdSV method was characterized by linear concentration range of the calibration curve from 1.5 to 40.0 ng mL<sup>-1</sup>. A great improvement towards CBZ electrochemical oxidation with low detection limit of CBZ (0.45 ng mL<sup>-1</sup>) in model system is achieved. Based on the parallel cyclic voltammetric investigation the adsorptive nature is proven for the certain electro-oxidation process. The obtained results indicate that TBACl-CPE with optimized SW-AdSV method could be applied for the trace level electroanalytical determination of CBZ in real samples.

**Acknowledgements:** The authors acknowledge the financial support of the Ministry of Science and Technological Development of the Republic of Serbia (Project No. 172059 and 172012) and CEEPUSIII (CZ-0212-12-1819) network.

### References

1. Y. She, Y. Tang, H. Liu, P. He, *Chemistry Central Journal* **4** (2010) 17 (<https://doi.org/10.1186/1752-153X-4-17>)
2. T. S. H. Pham, L. Fu, P. Mahon, G. Lai, A. Yu, *Electrocatalysis* **7** (2016) 411–419
3. (<https://doi.org/10.1007/s12678-016-0320-3>)
4. J. M. Petroni, B. G. Lucca, D. K. Fogliato, V. S. Ferreira, *Electroanalysis* **28** (2016) 1362–1369 (<https://doi.org/10.1002/elan.201501069>)
5. Y. Dong, L. Yang, L. Zhang, *Journal of Agricultural and Food Chemistry* **65** (2017) 727–736 (<https://doi.org/10.1021/acs.jafc.6b04675>)
6. L. N. Furini, C. J. L. Constantino, S. Sanchez-Cortes, J. C. Otero, I. López-Tocón, *Journal of Colloid and Interface Science* **465** (2016) 183–189 (<https://doi.org/10.1016/j.jcis.2015.11.045>)
7. Y. el Maataoui, M. el M'Rabet, A. Maaroufi, H. Oudda, A. Dahchour, *Turkish Journal of Chemistry* **41** (2017) 514–524 (DOI: [10.3906/kim-1612-56](https://doi.org/10.3906/kim-1612-56))

## Electrochemical behaviour of methyl 3-mercaptopropionate (3-MPA) at the Hg electrode

Ana Cvitešić Kušan, Irena Ciglencčki

Division for Marine and Environmental Research, Ruđer Bošković Institute, 10 000 Zagreb, Croatia,  
[irena@irb.hr](mailto:irena@irb.hr)

Strong interaction between mercury electrode (Hg) and sulfur (S) species serves as a background for their electroanalytical characterization/determination at the Hg electrode. The methodology is based on the tendency of inorganic and organic reduced S species (RSS) to deposit a HgS layer [1,2] and/or Hg-S species complexes [3] during an accumulation step at the deposition potential around -0.2 V vs. Ag/AgCl. In solutions containing sulfide anions, insoluble HgS layer at the Hg electrode surface is formed by the reversible process of a two-electron oxidation of the Hg at potentials more positive than -0.5 V [1,2]:



The same process occurs during the interaction of the Hg with some other organic and inorganic S species (thiourea, thiols, oxines, thioanions, polysulfides, dissolved and colloidal S, labile chalcogenides *i.e.* CuS, PbS, HgS, FeS, Ag<sub>2</sub>S). During the cathodic potential scan, layers of HgS and adsorbable Hg-S species complexes (in the case of DMS, DMDS, cysteine, glutathione) are reduced between -0.45 and -0.70 V with facilitated reduction of the Hg-S complexes at more positive potential than -0.68 V, where HgS reduction occurs [2,3]. Methyl 3-mercaptopropionate (3-MPA) is a compound that is frequently discussed in biogeochemical processes in the environment [4]. In addition to cysteine and glutathione, it is one of the most studied organosulfur compounds in natural systems. Its presence in natural waters (depending on whether it is a freshwater or marine system) is mainly explained by the interaction of sulfides and organic matter (acrylates) and/or it can be a product of the biochemical demethylation of dimethylsulfoniopropionate, the main osmolite within the phytoplankton cells. So far, the 3-MPA has been most explored in sediment samples mainly by chromatographic techniques [4,5].

This paper presents the background of electrochemical behaviour /determination of the 3-MPA (at the Hg electrode) in model electrolyte samples and in the mixture with sulfide. The same principle of determination will be applied for the characterization of S species in selected natural samples. Regarding the electrochemical behaviour of the 3-MPA at the Hg surface, and in comparison, with recorded voltammetric signals in natural samples, the 3-MPA can be a good representative for organosulfur, thiol-like compounds in water environment.

This work is supported by projects IP-11-2013-1205, SPHERE and IP-2018-01-1717, MARRES.

### References

1. G. W. Luther, A. E. Giblin, R. Varsolona, *Limnol. Oceanogr.* 30 (1985) 727.
2. D. Krznarić, I. Ciglencčki, B. Čosović, *Anal. Chim. Acta* 431 (2001) 269.
3. P. - J. Superville, I. Pižeta, D. Omanović, G. Billon, *Talanta* 112 (2013) 55.
4. E.S. Saltzman, W.J. Cooper (Editors), *Biogenic Sulfur in the Environment*. Am. Chem. Soc., Washington, DC, 1989.
5. E. M. Eitel, M. Taillefert, *Geochim Cosmochim. Acta* 215 (2017) 173.

## The SWV determination of esomeprazole at Au and its degradation at IrO<sub>x</sub> followed by HPLC and LC-MS

M. Avramov Ivić<sup>1</sup>, J. Lović<sup>1</sup>, N. Trišović<sup>2</sup>, J. Lađarević<sup>2</sup>, A. Mladenović<sup>2</sup>, M. Jadranin<sup>3</sup>, S. D. Petrović<sup>2</sup>, D. Mijin<sup>2</sup>

<sup>1</sup>ICTM – Institute of Electrochemistry, University of Belgrade, Njegoševa 12, 11000 Belgrade, Serbia

<sup>2</sup>Faculty of Technology and Metallurgy, University of Belgrade, Karnegijeva 4, 11000 Belgrade, Serbia

<sup>2</sup>Hemofarm Stada A.D. Vršac, Serbia

<sup>3</sup>Institute of Chemistry, Technology and Metallurgy – Department of Chemistry, University of Belgrade, Studentski trg 12-16, 11000 Belgrade, Serbia

[milka@tmf.bg.ac.rs](mailto:milka@tmf.bg.ac.rs)

Esomeprazole is well known as the most effective of the proton-pump inhibitors for the acid-related diseases. Its standard and injection powder were investigated by cyclic voltammetry (CV) and square wave voltammetry (SWV) at Au electrode in 0.05 M NaHCO<sub>3</sub>. CV showed that Au surface oxide acted as a necessary catalyst for the beginning and fully development of its electrooxidation reaction. A linear dependency of the anodic peak currents vs. esomeprazole standard concentrations was obtained for a set of concentrations from 3.0 to 500 µg mL<sup>-1</sup> by SWV. Using the constructed and validated calibration curve (the values of limit of detection (LOD) and limit of quantification (LOQ): 1.4 and 4.6 µg mL<sup>-1</sup>, respectively), the values of unknown esomeprazole concentrations in injection powder and in human serum spiked with standard were determined. At Au electrode esomeprazole was stable and, by HPLC analysis after three hours of cycling, a neglectable amount of the drug was changed. The oxidation of esomeprazole sodium under directed stress conditions using IrO<sub>x</sub> electrode showed its almost complete degradation after 3 h. HPLC and LCMS study revealed the formation of 4-hydroxy omeprazole sulphide, 4-hydroxy omeprazole sulphone, esomeprazole sulfone and methylated esomeprazole.

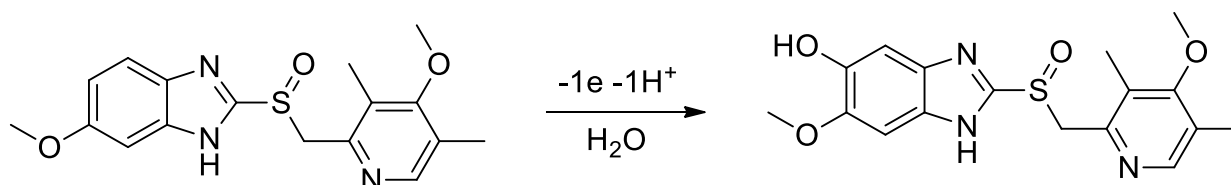

Scheme 1. Proposed oxidation mechanism for esomeprazole.

### References

1. A. E. Radi, A. Abd-Elkader, *Eurasian J. Anal. Chem.* **9** (2014) 92
2. A. E. Radi, N. A. El-Ghany, T. Wahdan, *Electroanal.* **28** (2016) 1112

## Study of electroactive properties of a new tetrazole azulene derivative for modified electrodes

Elena Diacu<sup>1</sup>, Eleonora-Mihaela Ungureanu<sup>1</sup>, Alexandru Anton Ivanov<sup>1,2</sup>, Sabina-Vasilica Pistol<sup>1</sup>,  
Veronica Anăstasoae<sup>1</sup>, Cristian Omocea<sup>1</sup>, Liviu Bîrzan<sup>3</sup>

<sup>1</sup>University "Politehnica" of Bucharest, Faculty of Applied Chemistry and Materials Science,  
Gheorghe Polizu 1-7, 011061 Bucharest, Romania

<sup>2</sup>National Institute for Research and Development in Environmental Protection,  
Splaiul Independentei 294, 060031 Bucharest, Romania

<sup>3</sup>Romanian Academy, Organic Chemistry Center "Costin D. Nenitzescu", 202B Splaiul Independentei,  
Bucharest, 060023, Bucharest, Romania

To assess the electroactive properties of the azulene compound (E)-5-(azulen-1-yl diazenyl)-1-benzyl-1H-tetrazole (**L**) an electrochemical study has been performed by using cyclic voltammetry (CV), differential pulse voltammetry (DPV) and rotating disk electrode (RDE) voltammetry using a PGSTAT 12 AUTOLAB potentiostat connected to a three-electrode cell. In the electrochemical experiments the working electrode was a glassy carbon disk and the electrolyte was 0.1M TBAP/CH<sub>3</sub>CN. All determinations were performed with degassed solutions (under argon) at 25°C. The anodic and cathodic CV and DPV scans have been recorded at different concentrations (0 – 2 mM) of **L** and different scan rates in CV.

Two anodic peaks (a1 – a2) and six cathodic peaks (c1 – c6) are distinguished either on CV, DPV and RDE curves. The peak currents increase with concentration, showing linear dependences of the peak currents on **L** concentration. Their equations and correlation coefficients have been established in order to check the character of electrochemical processes. Films were obtained both by successive scanning and by controlled potential electrolysis (CPE) for **L** (0.5 mM) in the domain of the anodic processes identified by CV. The evidence of films formation on the electrode surface was made by transferring the poly**L** modified electrodes in a solution of ferrocene in acetonitrile. The obtained results show the potential to use this poly**L** modified electrode in the detection of heavy metal ions.

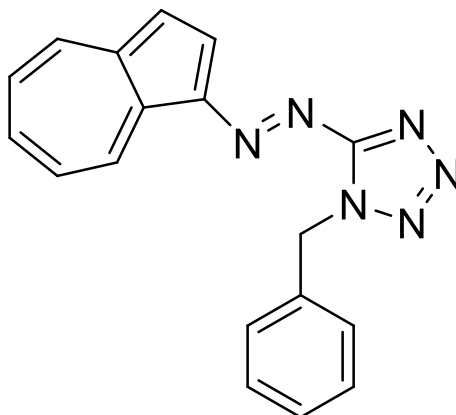

(E)-5-(azulen-1-yl diazenyl)-1-benzyl-1H-tetrazole (**L**)

### References

1. G.-O. Buica, I.-G. Lazar, L. Birzan, C. Lete, M. Prodana, M. Enachescu, V. Tecuceanu, A.B. Stoian, E.-M. Ungureanu, *Electrochimica Acta*, 263, 2018, 382-390.
2. G.-O. Buica, I.-G. Lazar, E. Saint-Aman, V. Tecuceanu, C. Dumitriu, A.A. Ivanov, A.B. Stoian, E.-M. Ungureanu, *Sensors and Actuators B: Chemical*, B 246, 2017, 434-443.
3. G.-G. Vasile, G.L. Arnold, G.-O. Buica, E. Diacu, E.-M. Ungureanu, C. Dinu, *Revista de Chimie*, 69, 1, 21-26, 2018.

## Electrochemical behaviour of new (azulen-1-yl-diazenyl)-heteroaromatic compounds containing 1,2,5-thiadiazol-3-yl moieties

Veronica Anăstasoae<sup>1</sup>, Laura Enache<sup>1</sup>, Cristian Omocea<sup>1</sup>, Liviu Bîrzan<sup>2</sup>, Raluca Isopescu<sup>1</sup>, Eleonora-Mihaela Ungureanu<sup>1</sup>

<sup>1</sup>University "Politehnica" of Bucharest, Faculty of Applied Chemistry and Materials Science, Gheorghe Polizu 1-7, 011061 Bucharest, Romania

<sup>2</sup>Institute of Organic Chemistry "C. D. Nenitzescu" of Romanian Academy, Spl. Independentei 202 B, P.O. Box 108, 060023 Bucharest 35, Romania

(E)-2-(Azulen-1-yl-diazenyl)-1,3,4-thiadiazoles substituted at azulen-1-yl moiety or at 5-position of thiadiazole ring were synthesized and characterized. The electrochemical behavior was examined by CV, DPV and RDE methods. The influence of the substituents on the redox potentials was analysed in order to improve their properties as promising dyes or complexing agents of these diazenes containing heterocycles. Linear correlations have been found for their oxidation and reduction potentials.

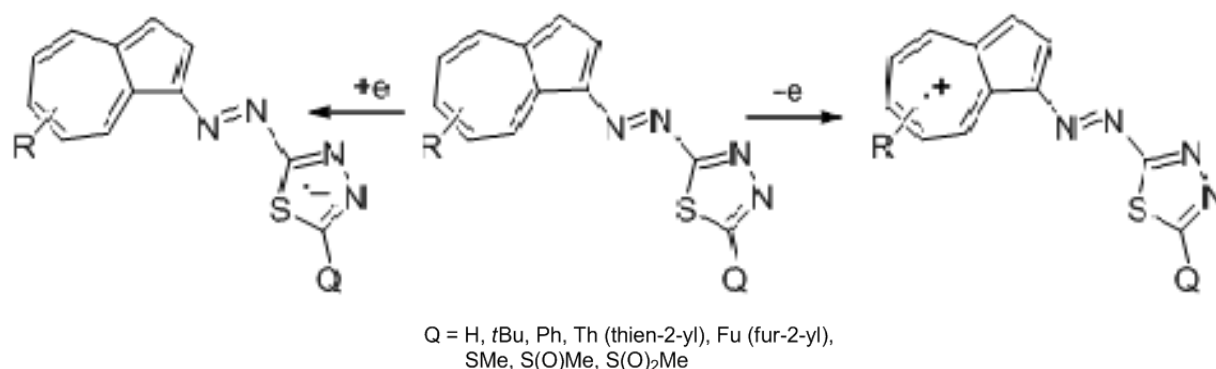

Scheme 1. Redox processes for azulen-1-yl-diazenyl-1,3,4-thiadiazoles; R = H; 4,6,8-Me<sub>3</sub>, 3,8-Me<sub>2</sub>-5-iPr

The study led to the finding of the best conditions for these compounds polymerization. Modified electrodes were characterized by cyclic voltammetry in ferrocene solutions. The complexing properties of this polyfunctional material were investigated for the recognition of heavy metals (Pb, Cd, Hg, Cu) by anodic pre-concentration technique.

*Acknowledgements:* The authors are grateful for the financial support from: PCCDI programe, INTELMAT project complement 5 and UEFISCDI project contract no. 236/2014.

### References

1. A. C. Razus, L. Birzan, M. Cristea, V. Tecuceanu, C. Draghici, *Rev. Chim. (Buc)* **66**(7) (2015) 1074.
2. E.-M. Ungureanu, A.C. Razus, L. Birzan, M.S. Cretu, G.-O. Buica, *Electrochim. Acta* **53** (2008) 7089.
3. G.-O. Buica, L. Birzan, V. Tecuceanu, A. C Razus, G.-L. Arnold, E.-M. Ungureanu, *Electroanalysis* **29** (2017) 93 – 102.

# **Organic Electrochemistry and Bioelectrochemistry**

## Electrochemical properties of 1-pentyl-3-(1-naphthoyl)indole and 1-pentyl-3-(2-methoxyphenylacetyl)indole

Michaela Obluková<sup>1</sup>, Romana Sokolová<sup>1</sup>, Ilaria Degano<sup>2</sup>, Radomír Čabala<sup>3</sup>

<sup>1</sup>J. Heyrovský Institute of Physical Chemistry of the Czech Academy of Sciences, Dolejškova 3, 182 23 Prague 8, Czech Republic

<sup>2</sup>University of Pisa, Department of Chemistry and Industrial Chemistry, Via Moruzzi 13, 56124 Pisa, Italy

<sup>3</sup>Charles University, 1st Faculty of Medicine, Kateřinská 1660/32, 12108 Prague 2

[michaela.oblukova@jh-inst.cas.cz](mailto:michaela.oblukova@jh-inst.cas.cz)

The electrochemical properties of 1-pentyl-3-(1-naphthoyl)indole (hereinafter referred to as “JWH-018”) and 1-pentyl-3-(2-methoxyphenylacetyl)indole (hereinafter referred to as “JWH-250”) were studied. These compounds belong to heterogenous group of synthetic cannabinoids, which have appeared in the drug market recently. These substances are abused for their psychoactive effect and serve as alternative to classical drugs (heroin, cocaine, ecstasy) due to their legal status [1]. In human organism, JWH-018 and JWH-250 are rapidly and completely metabolized and thus parent compounds are often undetectable. To detection of these compounds is necessary to know their metabolism pathways [2, 3].

In view of the fact that the electron transfer reactions play an important role in metabolic pathways; this study is focused on electrochemical investigation of oxidation and reduction of JWH-018 and JWH-250.

This report is based on cyclic voltammetry, UV/Vis and IR spectroelectrochemistry in non-aqueous media. Reactions products were identified by HPLC-ESI-MS/MS after oxidative and reductive exhaustive electrolysis.

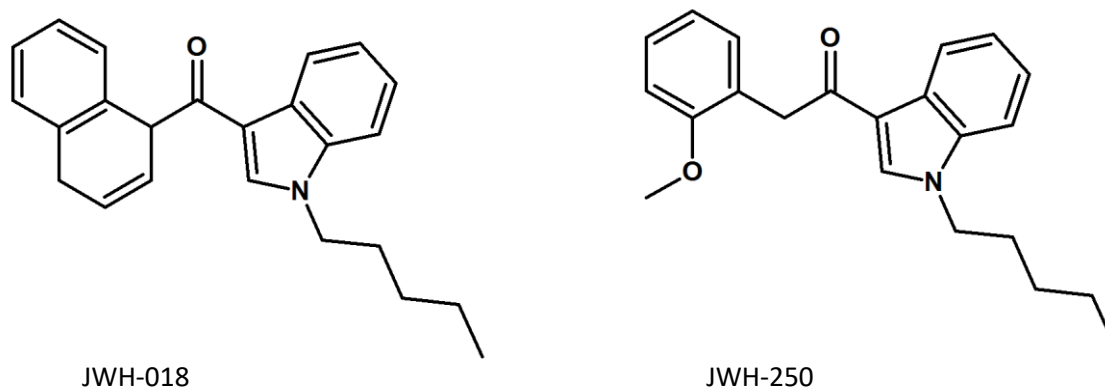

Figure 1: Chemical structure of JWH-018 and JWH-250

**Acknowledgement:** This work is supported by the Czech Science Foundation (GAČR 19-03160S).

### References

1. M. R. Meyer: *Arch. Toxicol.* **90** (2016) 2421.
2. A. Wintermeyer, I. Möller, M. Thevis, M. Jübner, J. Beike, M. A. Rothschild, K. Bender: *Anal. Bioanal. Chem.* **398** (2010) 2141.
3. A. Grigoryev, A. Melnik, S. Savchuk, A. Simonov, V. Rozhanets: *J. Chromatogr. B* **879** (2011) 2519.

## Electrochemical study on biomimetic activity of selected copper complexes in comparison with enzymes

Tomáš Mikysek<sup>1</sup>, Milan Sýs<sup>1</sup>, Miroslav Novák<sup>2</sup>

<sup>1</sup> Department of Analytical Chemistry, Faculty of Chemical Technology, University of Pardubice, Studentská 573, CZ-53210 Pardubice, Czech Republic

<sup>2</sup> Institute of Chemistry and Technology of Macromolecular Materials, Faculty of Chemical Technology, University of Pardubice, Studentská 573, CZ-53210 Pardubice, Czech Republic

[tomas.mikysek@upce.cz](mailto:tomas.mikysek@upce.cz)

The contribution represents synthesis and characterization of recently synthesized copper complexes (artificial enzymes) based on tyrosinase motif. Tyrosinase is a biologically important oxidase, which acts as the rate-limiting enzyme for controlling the production of melanin. It belongs to the group of proteins with a bicopper active center [1]. Unfortunately, tyrosinase has limited lifetime and therefore development of artificial enzymes offers new approach towards the higher stability e.g. in electrochemical sensors [2,3].

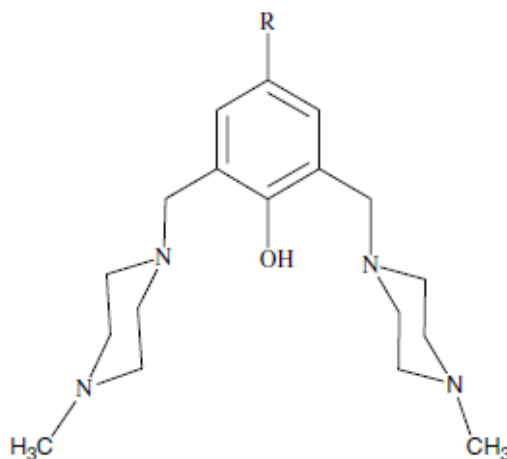

Figure 1. An example of structure of studied ligand ( $R = CHO$ ).

In order to drive the biomimetic (catalytic) activity of complexes under study towards different substrates (catechols, dopamine, etc.) various modifications in the ligand structure (Fig. 1) were performed. Their effect was further studied by electrochemical as well as spectroscopic methods in solid state and in solution. Moreover, another important role plays deposition of artificial enzyme complex on an electrode surface. The obtained results of kinetics of catalytic substrate conversion were compared with those obtained by using enzyme (tyrosinase).

*Acknowledgement:* This work is supported by the Czech Science Foundation (GAČR 19-03160S).

### References

1. C. A. Ramsden, P. A. Riley, *Bioorg. Med. Chem.* **22** (2014) 2388.
2. M. L. de Carvalho, M. Santhiago, R. A. Peralta, A. Neves, G. A. Micke, I. C. Vieira, *Talanta* **77** (2008) 394.
3. A. C. Franzoi, R. A. Peralta, A. Neves, I. C. Vieira, *Talanta* **78** (2009) 221.

## **General Topics**

## Coatings of chitosan/gelatin/Si-Ge nanoparticles by electrophoretic deposition on surgical grade stainless steel: electrochemical and antibacterial behaviour

Josefina Ballarre, Aldo R. Boccaccini<sup>1</sup>, Silvia M. Ceré<sup>2</sup>

*Applied Electrochemistry Div.-INTEMA, CONICET-UNMDP, Inst. for Biomaterials – FAU-Erlangen Nuremberg*

<sup>1</sup>*Inst. for Biomaterials – FAU-Erlangen Nuremberg, Germany*

<sup>2</sup>*Applied Electrochemistry Div.-INTEMA, CONICET-UNMDP, Argentina*

[jballarre@fi.mdp.edu.ar](mailto:jballarre@fi.mdp.edu.ar)

Metals are used in several orthopedic applications as fixation elements for the stabilization of fractures or as prostheses. One of the most common orthopedic material in the developing countries is surgical grade stainless steel (SS). However, its use as permanent implant in orthopaedic surgery is conditioned due to its limited corrosion resistance in physiological fluids as well as poor osseointegration and no antibacterial effect. The aim of this work is to generate a degradable film with antibacterial properties for stainless steel to be used in intracorporeal implants. The coating is generated by a biopolymer/silica-gentamicin nanoparticles composite generated by electrophoretic deposition (EPD) on stainless steel plates and screws. The layer was made by EPD at constant voltage, using a solution of a biopolymer mixture of chitosan and gelatin with ethanol as media. Also silica-gentamicin nanoparticles (Si-Ge np) were added to the EPD solution. Acidic low pH ranges during the EPD lead to a multiple positively charged and intermolecular stabilized composite, which migrates to the cathode after applying an electrical field. A local increase of pH causes near the cathode chemical reductions, which result in hydrogen generation. Consequently, deprotonation of amino groups of chitosan occurs. Finally, chitosan becomes insoluble and is deposited on the electrode together with gelatin and silica nano particles.

Coatings were characterized by SEM, FTIR, contact angle and roughness tests. *In vitro* tests were carried on to analyse coatings degradation, antibiotics release, cell attachment (ST2 stromal cells) and bacterial (E. Coli and Staphylococcus aureus) inhibition. Also electrochemical assays were carried out with a conventional three electrode cell to evaluate the coating performance. SBF was used throughout the experiments.

EPD coatings were uniform and adapted to the SS substrate also in the screw-shape. The distribution of silica-gentamicin nanoparticles was acceptable in all the coated area. The degradation of the chitosan-gelatin coatings was evident after 7 days of immersion, but the cellular response was still good. The gentamicin release showed excellent antibacterial behavior at after 24h.

The proposed coating system has promising behavior to prevent hospital infections at early implantation times.

## A study on property and performance according to the pore structure of metallic porous separator for hydrogen fuel cell vehicles

Myong Hwan Kim, Youngmo Goo, Ji-Young Park, Seung-Eul Yoo

*Korea Automotive Technology Institute*

[kimmh@katech.re.kr](mailto:kimmh@katech.re.kr)

In generally, Bipolar plate is vital component of PEM fuel cells, which supplies fuel and oxidant to reactive sites, removes reaction products, collects produced current and provides mechanical support for the cells in the stack. At the present, the bipolar plate for fuel cell vehicle is metallic separators formed of metallic materials such as stainless steel. The existing bipolar plate includes a land(contacting) portion directly bonded to the gas diffusion layer (GDL) and a channel portion that serves as a supply passage of reaction gases and an exhaust passage of water between land portions. In the typical separator, the land portion and the channel portion are disposed in a longitudinal direction and a flow field area in which the channel portion is formed both have a longitudinal structure. Also, the land portion and the channel portion are distinctly separated from each other.

However, in the case of a typical separator, this non-uniformity causes a concentration difference between the area that the channel portion contacts and the area that the land portion contacts among the whole area of the MEA where the electrochemical reaction occurs and the performance of fuel cell is decreased.

In this paper, a porous separator with various structures for a fuel cell, which causes the high diffusion of reactant gases was studied for increasing the performance of fuel cell. Also, we conducted an analysis of the properties (contact resistance, corrosion etc.), machinability (uniformity of thickness, change of hole structure etc.) and performance according to hole and pitch structure.

In conclusions, the porous separator with optimum structure shows the performance above 400mA/cm<sup>2</sup> at 0.6V in comparison with the typical separator. It is considered to be minimize concentration differences between area in a gas diffusion layer and achieve uniform electrochemical reaction and electricity generation over the whole reaction are, by improving the structure of a flow field in which reactant gases flow.

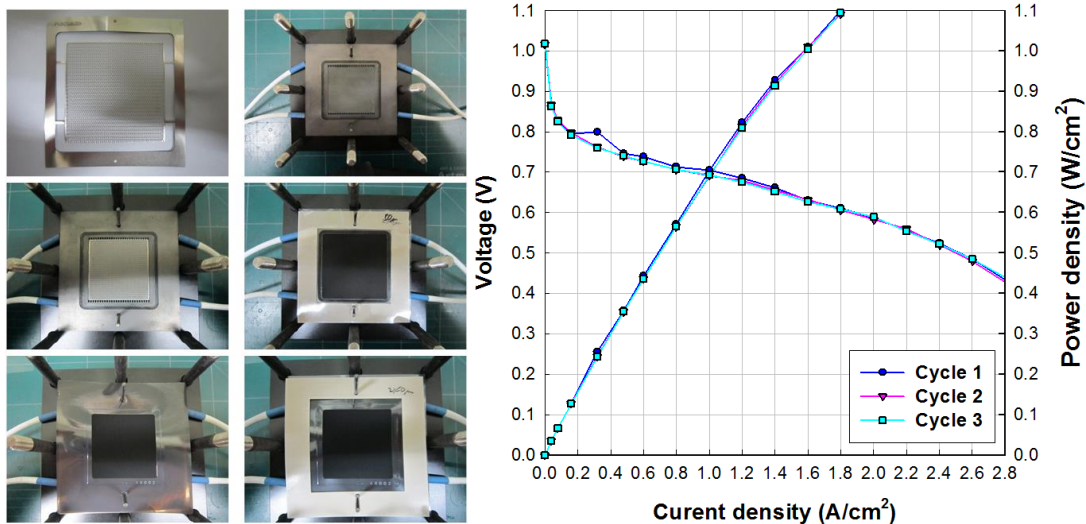

### References

1. Atul Kumar, R.G Reddy, *Journal of Power Sources*, **114**(1) (2003) 54-62
2. Chung-Jen Tseng, Bin Tsang Tsai, Zhong-Sheng Liu, Tien-Chun Cheng, Wen-Chen Chang, Shih-Kun Lo, *Energy Conversion and Management*, **62** (2012) 14-21

## An interaction of nanostructured carbon based composites with electromagnetic waves in the wide frequency range

Viacheslav Barsukov, Volodymyr Khomenko, Oksana Butenko, Ilona Senyk

*Department of Electrochemical Power Engineering and Chemistry*

*Kyiv National University of Technologies and Design, 2 Nemyrovych-Danchenka str., Kyiv 01011 Ukraine*

[v-barsukov@i.ua](mailto:v-barsukov@i.ua)

Carbon-based nanomaterials including carbon filaments, carbon nanofibers, carbon nanotubes [1], and more recently graphene [2], have been used as conductive fillers to fabricate composite materials for electromagnetic shielding, because of their good characteristics, the respective shielding depending on both absorption and reflection of the incoming electromagnetic radiation.

Our team used such nanostructured component as graphitized carbon black PUREBLACK® (USA) [3] in combination with the colloidal graphite CGP (S-1) from Zavalivskii Graphite (Ukraine) for preparation of quite effective and not expensive coating [4] with a thickness of 160-200  $\mu\text{m}$ . The graphite/carbon black ratio was 3:1 in this composite.

In order to estimate an effectiveness of shielding, a flat sample of electromagnetic screen in a 30 x 30  $\text{cm}^2$  was placed between the generator and the signal receiver located inside a shielded chamber. The following devices have been used for measurements: (1) ADF435x Microwave Wideband Generator; (2) RF Spectrum Analyzer series SPECTRAN HF-4040 V3. The antenna of the generator propagates the signal in all directions. This signal is captured by a spectrum analyzer, which sequentially scans the signal at different frequencies in the range from 300 MHz to 4000 MHz. On the path of the electromagnetic wave an experimental sample was established. The signal power is measured without an electromagnetic screen ( $P_0$ ), and then with a screen ( $P_1$ ). The screening efficiency (dB) of studied material  $L = 10 \cdot \lg(P_0/P_1)$  depends strongly of a frequency and varies widely enough. According to our data, the highest values of -30 and -40 dB are observed at the frequencies ca 2700 and 3550 MHz, correspondingly, in the above-mentioned range.

We have developed a special coating for electronic devices, based on the above-mentioned carbon-graphite materials and some transition metal oxides, which ensure a good compatibility of electronic devices. This coating was tested in some real devices for its compliance with the MIL-STD 461F standard of the US Ministry of Defence and compared with the most similar foreign analog – the protective coating #842 MG Chemicals (Burlington, Ontario, Canada) based on silver particles [5].

The results indicate that the developed protective coating containing oxides of transition metals is on a par with the Canadian standard sample based on silver particles over the whole frequency range under study, and has much lower cost and simplified applicability.

*Acknowledgement:* This research was sponsored in part by the NATO Science for Peace and Security Programme under grant G5477.

### References

1. M. Han, X. Yin, S. Ren, W. Duan, L. Zhang, L. Cheng, *RSC Adv.* **6** (2016) 6467.
2. E. Drakakis, E. Kymakis, G. Tzagkarakis, et al., *Appl. Surf. Sci.* **398** (2017) 15.
3. I. Barsukov, M. Gallego, J. Doninger, *J. Power Sources*, **2** (2006) 288.
4. V. Barsukov, O. Butenko, I. Senyk, O. Kryukova, *Materials Today: Proceedings* **5** (2018) 8/1, 15909.
5. EMI and RFI shielding: <http://www.mgchemicals.com/products/emi-and-rfi-shielding/>

## pH-anion interplay in the electrochemical dissolution of platinum

Cornelia Diaç<sup>1,2</sup>, Cătălin Ceauş<sup>1</sup>, Elena Iulia Cucolea<sup>1</sup>, Valeriu Filip<sup>2</sup>, Şerban Stamatini<sup>1</sup>

<sup>1</sup>Nano-SAE Research Centre, PO Box MG-38, Bucharest – Magurele, Romania

<sup>2</sup>University of Bucharest, Faculty of Physics, PO Box MG-38, Bucharest – Magurele, Romania

[serban@3nanosae.org](mailto:serban@3nanosae.org)

Platinum is widely used in the jewellery, automotive, medicine and electronic industries [1]. Platinum recycling has become very important in the last few years due to the limited availability [2]. Traditional recovery methods involve the use of acids at high concentrations or the use of energy intensive equipment (temperatures higher than 2000 °C). The above mentioned methods have a negative impact on the environment [3], which is why alternative methods are required. Electrochemical methods may be the answer to these problems because they aren't harmful for the environment. Electrochemical dissolution of platinum at different pH values was studied in this work. The role of anion was also discussed. The dissolution rate was determined by ICP – OES. UV-Vis was used for determining the structure of the Pt complex. Elemental analysis of the electrolytes showed that the largest dissolution rates were achieved in HCl, followed by H<sub>2</sub>SO<sub>4</sub> and KCl. We show the interplay between proton and anion concentration that can lead to a better understanding of electrochemical dissolution at platinum electrodes.

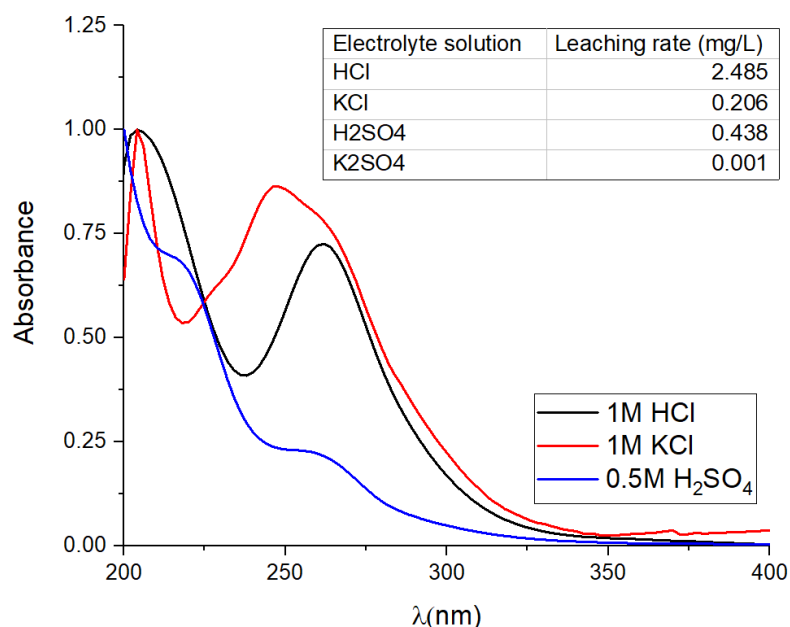

### References

1. Johnson Matthey, Precious Metals Management Summary of Platinum Supply & Demand In 2017, Pgm Market Report February 2018
2. W. Black, *The platinum group metals industry*, Woodhead Publishing limited (2000)
3. Z. Peng, Z. Li, X. Lin, H. Tang, L. Ye, Y. Ma, M. Rao, Y. Zhang, G. Li, *Pyrometallurgical Recovery of Platinum Group Metals from Spent Catalysts*, The Minerals, Metals & Materials Society (2017)

# **8<sup>th</sup> Kurt Schwabe Symposium**

## New electrochemical and physical measurements on sensitive glasses in thin-film technology

Frank Gerlach, Kristina Ahlborn, Winfried Vonau

Kurt-Schwabe-Institut für Mess- und Sensortechnik e.V. Meinsberg

[frank.gerlach@ksi-meinsberg.de](mailto:frank.gerlach@ksi-meinsberg.de)

All solid state sensors have several advantages compared to conventional ones. These include, *e.g.*, miniaturization, planar design, location independence and the uncomplicated realization of sensors for high pressure and high temperature. Therefore, a number of physical sensors, such as temperature sensors, pressure sensors, rotation angle sensors and force sensors are available in thin-film techniques.

Electrochemical sensors seem to be more sophisticated because miniaturization and layer technologies reduce long-time stability and electrochemical performance compared to optical and conventional measurement technologies.

The present contribution deals with the fabrication of thin layers - especially of chemical sensitive glass-layers - by pulsed laser ablation and with deposition of oxide layers by means of sputtering processes.

The focus is directed to pretreatment of alumina substrates using screen printing methods to ensure the necessary thin-film quality of the surfaces to be coated.

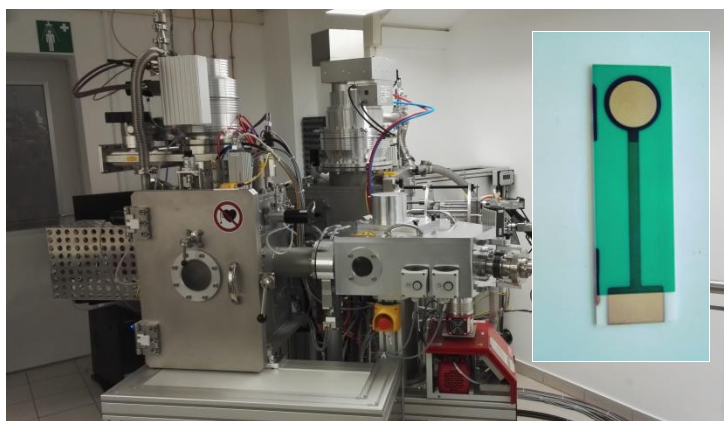

Figure 1: combined coating unit, glass-based sensor-chip on alumina substrate

The characterization of sensitive glass layers with analytical, electrochemical and physical methods is often not comparable to that of classical liquid-filled glass systems due to small layer thickness and specific material-dependent interlayer effects. Special effects occur in the system-related transition from ionic conduction of the glasses to electron conduction of noble metal based pick-up electrodes. [1]

In addition bulk properties of the layers are modified due to the ablation process.

These and other sensory properties are investigated and means and methods are shown to improve the sensor performance by optimizing the coating process and the structure of thin-film sensors [2, 3].

The results are shown exemplary for the development of pH-sensors and redox-sensitive sensors made by thin-film technique.

### References

1. H. Bach, F.G.K. Baucke, D. Krause: *Electrochemistry of Glasses and Glass Melts, Including Glass Electrodes*, Springer-Verlag Berlin Heidelberg 2001, 190-242, ISBN 3-540-58608-3
2. K. Ahlborn, F. Gerlach, W. Vonau: PLD as a new technology for the fabrication of pH glass based planar electrochemical sensors, *International Journal on Advances in Systems and Measurements* 10 (2017) 56-63, ISSN 1942-261x
3. W. Vonau, F. Gerlach, K. Ahlborn: PLD as possible tool for the fabrication of chemosensors based on amorphous membranes, *Proceedings of SENSORDEVICES 2016: 7th International Conference on Sensor Device Technologies and Applications*, Nice, France, 24.07.-28.07.2016, 98, (1Vol), ISBN: 9781510826922

## Application of a glassy carbon in the voltammetric determination of pesticides

Andrzej Leniart, Mariola Brycht, Barbara Burnat, Sławomira Skrzypek

University of Lodz, Faculty of Chemistry, Department of Inorganic and Analytical Chemistry

Tamka 12, 91-403 Lodz, Poland

[andrzej.leniart@chemia.uni.lodz.pl](mailto:andrzej.leniart@chemia.uni.lodz.pl)

Pesticides are substances of natural or synthetic origin. The use of pesticides on the one hand brings benefits to people through the protection of plants and food against various harmful factors. On the other hand, the use of pesticides in an unlimited way leads to poisoning of water bodies, animals, food products and also people. Therefore, supervision and constant control of pesticides and their residues occurring both in the environment and in food products is of utmost importance. Besides the chromatographic and spectroscopic methods for pesticide determination, electrochemically (mainly voltammetric) techniques are used.

Carbon is commonly used as an electrode materials in analytical electrochemistry. One of the varieties of carbon used as working electrode is a glassy carbon. The glassy carbon (GC) combines the properties of glass and ceramics with graphite properties. It is prepared from the various organic precursors, e.g. polyacrylonitrile, phenol-formaldehyde resin. These precursors are subjected to carbonization under pressure in an inert atmosphere at high temperature 1000-3000°C [1,2]. From the point of view of electroanalysis glassy carbon has many advantages such as chemical and electrochemical inertness, wide potential window, and electrocatalytic activity for a many of redox reactions. This is particularly important in the case of the electrochemical determination of organic compounds, both aqueous and non-aqueous solutions. As an electrode material, glassy carbon is used in the form of rods, plates and powder.

The purpose of the presented work was to develop electrochemical procedures for the quantitative determination of selected pesticides: Oxycarboxin (*Oxy*), Protham (*Pro*) and Fluometuron (*Flu*). In this study three forms of working electrode based on glassy carbon were used: bulk glassy carbon electrode (GCE), bulk glassy carbon electrode modified with multi-walled carbon nanotubes (GCE/MWCNTs) and glassy carbon paste electrode (GCPE). The research was carried out using square wave voltammetry technique (SWV). Selected obtained results for the quantitative determination of pesticide are presented in Table 1. Additionally, the surface characterization of bare GCE, GCE/MWCNTs and GCPE was evaluated with an atomic force microscopy (AFM) and a scanning electron microscopy (SEM).

Table 1. Obtained limits of detection (LOD) and quantification (LOQ) for investigated of pesticide

Pesticide	Working Electrode	LOD (mol L <sup>-1</sup> )	LOQ (mol L <sup>-1</sup> )
<i>Oxycarboxin</i>	GCE	2.0×10 <sup>-6</sup>	6.7×10 <sup>-6</sup>
<i>Protham</i>	GCE/MWCNTs	7.6×10 <sup>-7</sup>	2.3×10 <sup>-6</sup>
<i>Fluometuron</i>	GCPE	7.4×10 <sup>-7</sup>	2.2×10 <sup>-6</sup>

### References

1. W.E. Van der Linden, J.W. Dieker, *Analytica Chimica Acta* **119** (1980) 1-24 ([https://doi.org/10.1016/S0003-2670\(00\)00025-8](https://doi.org/10.1016/S0003-2670(00)00025-8))
2. R. L. McCreery, *Chemical Reviews* **108** (2008) 2646-2687 (<https://pubs.acs.org/doi/abs/10.1021/cr068076m>)

## Combined calorimetric gas sensor/spore-based biosensor for monitoring of gaseous sterilization processes

Jan Oberländer<sup>1,2</sup>, Julio Arreola<sup>1,2</sup>, Michael Keusgen<sup>2</sup>, Michael J. Schöning<sup>1,3</sup>

<sup>1</sup>*Institute of Nano- and Biotechnologies (INB), FH Aachen, Jülich, Germany*

<sup>2</sup>*Department of Pharmaceutical Chemistry, Philipps-Universität Marburg, Marburg, Germany*

<sup>3</sup>*Institute of Complex Systems (ICS-8), Forschungszentrum Jülich GmbH, Jülich, Germany*  
[schoening@fh-aachen.de](mailto:schoening@fh-aachen.de)

Nowadays, gaseous H<sub>2</sub>O<sub>2</sub> is often used as sterilization agent in aseptic filling systems, which are commonly applied in food and pharmaceutical industries. The validation of sterilization efficacy is typically performed by costly and time-consuming microbiological methods such as count reduction- or end point tests. Two different sensor approaches have been developed to monitor the gaseous H<sub>2</sub>O<sub>2</sub> sterilization process:

1) A thin-film calorimetric H<sub>2</sub>O<sub>2</sub> gas sensor has been realized to enable a rapid inline process control. The calorimetric detection principle relies on the exothermic decomposition of H<sub>2</sub>O<sub>2</sub> on a catalytic surface such as manganese(IV) oxide (MnO<sub>2</sub>). The sensing principle of the calorimetric H<sub>2</sub>O<sub>2</sub> gas sensor is based on resistance temperature detectors on various substrates, like silicon, glass or flexible polyimide foil. The developed sensors can be applied in aseptic filling machines to monitor the concentration of H<sub>2</sub>O<sub>2</sub> after the evaporator. Moreover, the developed thin-film sensors are capable to monitor the sterilization process at the end of the process chain within food packages.

2) In addition, an impedimetric biosensor has been developed to capture interactions of the gaseous sterilization process on standardized test organisms (*Bacillus atrophaeus*). The biosensor is based on interdigitated electrodes on which resilient microorganisms are immobilized. The interdigitated electrode structures consist of a differential measurement set-up, one electrode pair immobilized with spores whereas the second electrode pair serves as a reference. Morphological deformations of the resilient microorganisms depending on the varying H<sub>2</sub>O<sub>2</sub> concentration result in an impedance change, which can be related to the microbiological kill rate.

*Acknowledgements:* The authors thank the German Federal Ministry of Education and Research, Project “ImpediPack” and the European Union together with the Ministry of Economic Affairs, Energy and Industry of the State of North Rhine Westphalia, Program “EFRE-NRW 2014-2020, Project “EfficientSterile”.

## Development of a field-effect biosensor to control the acetoin concentration during fermentation processes

Melanie Jablonski<sup>1,2</sup>, Denise Molinnus<sup>1,2</sup>, Lukas Muschallik<sup>1</sup>, Johannes Bongaerts<sup>1</sup>, Torsten Wagner<sup>1</sup>, Thorsten Selmer<sup>1</sup>, Petra Siegert<sup>1</sup>, Michael Keusgen<sup>2</sup>, Michael J. Schöning<sup>1,3</sup>

<sup>1</sup>*Institute of Nano- and Biotechnologies (INB), FH Aachen, Campus Jülich, Jülich, Germany*

<sup>2</sup>*Department of Pharmaceutical Chemistry, Philipps-University Marburg, Marburg, Germany*

<sup>3</sup>*Institute of Complex Systems (ICS-8), Forschungszentrum Jülich GmbH, Jülich, Germany*

[molinnus@fh-aachen.de](mailto:molinnus@fh-aachen.de)

Acetoin and diacetyl are naturally occurring compounds in *e.g.*, fruits, corn or meat and are employed in food or cosmetics as flavour or fragrance. However, at elevated concentrations, a strong buttery-like taste and aroma develops, causing undesirable attributes such as in alcoholic beverages, like beer or wine. Hence, the detection of acetoin and diacetyl could not only monitor the quality of the fermentation process but also could avoid unnecessary maturation or vinous fermentation.

In this work, a capacitive electrolyte-insulator-semiconductor (EIS) field-effect biosensor modified by the enzyme acetoin reductase [1] from *B. clausii* DSM 8716<sup>T</sup> (developed in our institute) for the detection of acetoin has been presented. Acetoin will be reduced by the enzyme to 2,3-butanediol, while NADH serves as a cofactor, inducing a pH change which can be monitored by the EIS biosensor. The developed acetoin biosensor exhibits a linear behaviour in the acetoin concentration range between 10  $\mu$ M and 100  $\mu$ M measured in buffer solution. Furthermore, preliminary studies in real probes (white-/red wine and beer) by varying acetoin concentrations have been successfully carried out.

*Acknowledgements:* The authors thank the Ministry of Innovation, Science and Research of the state of North Rhine-Westphalia for financial support (funding program FH-Struktur 2016).

### References

1. L. Muschallik, D. Molinnus, J. Bongaerts, M. Pohl, T. Wagner, M.J. Schöning, P. Siegert, T. Selmer, J. Biotechnol., 258, (2017), 41-50.

## **A simple approach for the preparation of ring ultramicroelectrodes in the context of combined scanning electrochemical microscopy and scanning ion conductance microscopy**

Stefan Wert, Timo Raith, Frank-Michael Matysik

*University of Regensburg, Universitätsstr. 31, 93053 Regensburg, Germany*

[frank-michael.matysik@chemie.uni-regensburg.de](mailto:frank-michael.matysik@chemie.uni-regensburg.de)

Scanning electrochemical microscopy (SECM) has proven to be a powerful method for the investigation of electrochemical properties of surfaces. For acquiring simultaneous information about the sample topography, scanning ion conductance microscopy (SICM) can be utilized. The hyphenation of these two techniques can be realized by using a micropipette with an integrated ring ultramicroelectrode (UME) as probe. Therefore, a simple approach for the fabrication of ring UMEs is presented. The fabrication of UMEs was performed by coating platinum-coated, pulled glass capillaries with a photoresist. Usually, multiple layers had to be applied for obtaining functional UMEs. The coating process was investigated by optical microscopy and scanning electron microscopy imaging, as well as cyclic voltammetry.

The electrochemical behavior and the topography of a patterned platinum substrate electrode and an interdigitated electrode array were investigated by the means of combined SECM and SICM. Electrochemical experiments were carried out with ferrocenemethanol (1.5 mM) as redox mediator and potassium nitrate (0.2 M) as supporting electrolyte in the bulk solution.

# **Satellite Student Symposium**

## Electrochemical analysis of cobalt, nickel and selenium codeposition process from acidic solutions

Dawid Kutyla, Katarzyna Skibińska, Anna Kwiecińska, Karolina Kołczyk- Siedlecka, Piotr Żabiński, Remigiusz Kowalik

AGH University of Science and Technology, al. Mickiewicza 30, Krakow 30-059  
[kwiec@agh.edu.pl](mailto:kwiec@agh.edu.pl)

The electrochemical deposition of transition metal chalcogenides thin films has received recently much attention due to their potential applications in electrocatalysis. Among them the special attention is focused on cobalt-selenium system. Usually, thin films of these materials are prepared by hydrothermal synthesis or high temperature and vacuum techniques. However electrodeposition has been found to be a very good and low-cost method to fabricate thin polycrystalline films of these compounds. The electrodeposition of thin films of polycrystalline Ni-Co-Se system from aqueous baths was studied. The experiments were carried out following the thermodynamic analysis. A conventional three-electrode cell: Cu as working electrode, Pt-sheet as counter electrode and Saturated Calomel Electrode (SCE) as reference electrode was used. The electrodeposition mechanism of pure elements Ni, Se, Co and Co-Ni-Se phases on copper substrate was studied by chronoamperometry, cyclic voltammetry and hydrodynamic techniques. Thin films were deposited potentiostatically on copper substrate. The influence of potential deposition, NiSO<sub>4</sub>, H<sub>2</sub>SeO<sub>3</sub> and CoSO<sub>4</sub> concentration, pH and bath temperature on the chemical composition of the films was discussed. The formation of Ni-Co-Se intermetallic phases was confirmed by X-ray diffraction. The chemical composition of the deposits was determined by XRF and EDS analysis. Morphology of the deposits was examined by scanning electron microscopy.

This work was supported by the Polish National Centre of Science under grant UMO-2016/21/B/ST8/00431. The authors would like to acknowledge the COST MP1407 Action for networking.

### References

1. D. J. Kutala, K. A. Kołczyk, Piotr Żabiński, Remigiusz Kowalik *Journal of the Electrochemical Society* 2017 **vol. 164** iss. 12, s. D700–D706. (<http://jes.ecsdl.org/content/164/12/D700>)

## Synthesis of copper 1D nanocone array electrodes using aluminum oxide template

Katarzyna Skibinska, Karolina Kolczyk-Siedlecka, Dawid Kutyla, Anna Kwiecinska, Remigiusz Kowalik, Piotr Zabinski

AGH University of Science and Technology, Faculty of Non-Ferrous Metals,  
Mickiewicza 30, 30-059, Krakow, Poland

[kskib@agh.edu.pl](mailto:kskib@agh.edu.pl)

Nanocones material is an example of one-dimensional (1D) nanostructures which can offer better catalytic properties than bulk material [1] due to their large active surface area and small geometrical size.

Porous anodic aluminum oxide (AAO) is a popular template for synthesis of ordered arrays of nanostructured materials. Electrolyte, its concentration and temperature, applied voltage or current and duration of anodization can control geometrical features like pore diameter, interpore distance and thickness of AAO. Also the duration of the second step, used electrolyte and number of cycles in case of two-step anodization can affect on these properties. Conical nanopores can be obtained basing on alternating repetition of the anodization and pore widening process during fabrication of AAO.

The first and second steps of anodization were carried out in phosphoric, oxalic and sulfuric acid solution. The second step of anodization contains short-period anodization at 9°C and pores widened in 5% H<sub>3</sub>PO<sub>4</sub> at 30°C. Thin copper layer had been sputter deposited on sample to ensure conductivity. To obtain free standing Cu nanocones the Al<sub>2</sub>O<sub>3</sub> template was chemically etched in dilute phosphoric acid solution.

In this case the anodization of AA1050 was performed. The process of copper electrodeposition was carried out in a two-electrode cell. The working electrode was AAO sample, the anode was a platinum plate. The SEM pictures show obtained template.

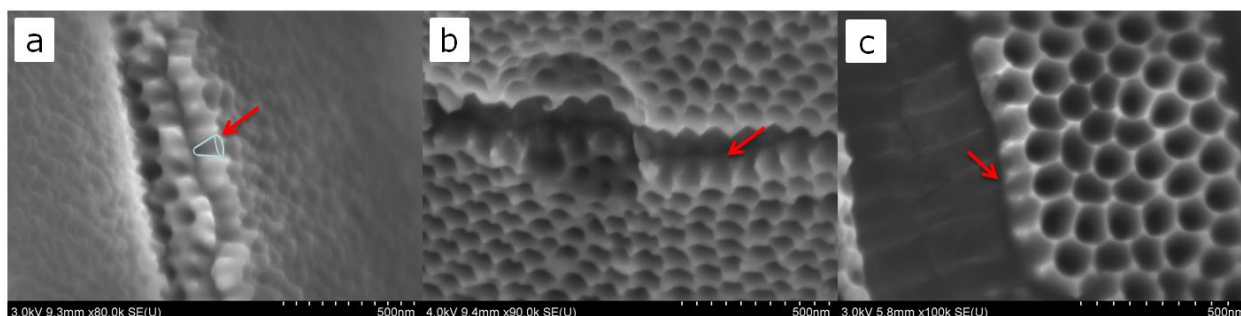

SEM cross-sectional images of Al<sub>2</sub>O<sub>3</sub>/Al template characterized by conical nanopores with different number of anodizing and pore expansion cycles: (a) 4, (b) 6, (c) 8 in 0.3 M H<sub>2</sub>C<sub>2</sub>O<sub>4</sub> at 45V and 9°C.

Influence of different acid solutions with corresponding temperature and applied voltage in the first step of anodization was examined. The influence of annealing temperature for aluminium AA1050 on size and distribution of nanocones was determined. An attempt was made to measure nanocones electrocatalytic properties.

### References

1. Kurowska E., Brzozka A., Jarosz M., Sulka G. D., Jaskula M., "Silver nanowire array sensor for sensitive and rapid detection of H<sub>2</sub>O<sub>2</sub>," *Electrochimica Acta*, 104, pp. 439–447 (2013).

## IrO<sub>2</sub>/TiO<sub>2</sub>: synthesis and characterization

Nina Dimitrova<sup>1</sup>, J. Georgieva<sup>1</sup>, S. Sotiropoulos<sup>2</sup>, Tz. Boiadjieva-Scherzer<sup>3</sup>

<sup>1</sup>*Institute of Physical Chemistry, Bulgarian Academy of Sciences, Sofia 1113, Bulgaria*

<sup>2</sup>*Department of Chemistry, Aristotle University of Thessaloniki, Thessaloniki 54124, Greece*

<sup>3</sup>*CEST Kompetenzzentrum für elektrochemische Oberflächentechnologie GmbH, Wiener Neustadt, Austria*

A facile, alternative method was developed to combine the properties of TiO<sub>2</sub> with the electrocatalytic activity of IrO<sub>2</sub> for oxygen evolution reaction. Ir was deposited on the surface of TiO<sub>2</sub> powder by UV photodeposition from appropriate Ir salt aqueous solutions. Catalytic materials with different Ir content were obtained.

The resulting IrO<sub>2</sub>/TiO<sub>2</sub> composites have been characterized by transmission electron microscopy (TEM), energy-dispersive spectrometry (EDS) and X-ray photoelectron spectroscopy (XPS). The analysis showed that Ir on the surface is mainly in oxidized state (IrO<sub>2</sub>).

The electrochemical characterization of the resulting composites was carried out by cyclic voltammetry (to identify the surface electrochemistry of the catalyst) and linear sweep voltammetry to test their catalytic activity.

*Acknowledgments:* Financial support of CEST, Austria in the frame of the COMET program is gratefully acknowledged.

## Investigation of Ir deposited on different non-carbon supports as catalyst for OER in PEMEC

Iveta Boshnakova, Elefteria Lefterova, Denis Paskalev, Evelina Slavcheva

*Institute of Electrochemistry and Energy Systems "Acad. Evgeni Budevski" - Bulgaria Academy of Sciences*  
[boshnakova.iveta@iees.bas.bg](mailto:boshnakova.iveta@iees.bas.bg)

The electrolysis of water is the most attractive technology for producing pure hydrogen and if powered by electricity generated from renewable sources (*e.g.*, sunlight, wind, *etc.*), it is a zero emission environmentally friendly process. The main challenge preventing the use of PEMEC for massive industrial hydrogen production is the sluggish kinetics of the oxygen evolution reaction (OER) requiring noble metal catalysts. Among these, IrO<sub>2</sub> is, the most resistant and highly efficient one. The application of pure iridium oxide is strongly restricted by its high costs and limited resources. The common approach to increase the metal utilisation and thus, to reduce the loading and cost, is the use of catalytic supports with high surface area. The state-of-art catalytic supports such as various porous carbon blacks cannot meet all requirements imposed by the harsh operation condition at the anode during electrolysis of water

The present research has been focused on the reduction of Ir noble-metal loading by its deposition on mesoporous Ti and Sn based oxide supports. A series of catalysts having different metal/support ratio have been synthesized as nanoparticles using the well established sol gel technique. They have been characterized in terms of structural (XRD) and morphological (SEM) features. Their electrochemical behaviour and catalytic activity towards the oxygen evolution reaction have been investigated in 0.5M H<sub>2</sub>SO<sub>4</sub> and in a laboratory polymer electrolyte membrane electrolysis cell (PEMEC). It has been found that due to synergetic effects between iridium and the used interactive oxide support, the loading of the noble metal can be reduced essentially without sacrifice of efficiency, thus decreasing the cost of catalysis.

## Influence of the ultrasound on the properties of electrodeposited Zn-Co alloys

Marija Riđošić<sup>1,2</sup>, Eva Garcia-Lecina<sup>3</sup>, Asier Salicio Paz<sup>3</sup>, Ljiljana Živković<sup>4</sup>, Jelena Bajat<sup>2</sup>

<sup>1</sup>Faculty of Technology, University of East Sarajevo, 75400 Zvornik, RS, Bosnia and Herzegovina

<sup>2</sup>Faculty of Technology and Metallurgy, University of Belgrade, P.O. Box 3503, 11120 Belgrade, Serbia

<sup>3</sup>CIDETEC Surface Engineering, E-20014, San Sebastian, Spain

<sup>4</sup>The Vinča Institute for Nuclear Sciences, University of Belgrade, P.O. Box 522, 11001 Belgrade, Serbia

[marija.ridjosic@tfzv.ues.rs.ba](mailto:marija.ridjosic@tfzv.ues.rs.ba)

Protective coatings are widely used in different industrial area for improving a range of surface properties. Zinc coatings are mainly used to protect iron and steel substrates against corrosion. Zinc alloy coatings provide better protective properties of steel compared to pure zinc coatings. Metals like iron, cobalt and nickel employed like alloying elements are nobler than Zn and their presence in Zn alloy results in higher corrosion resistance. About 1 wt% of cobalt in alloy is needed to obtain similar corrosion resistance to Zn-Ni alloy with 10 wt% of Ni. Ultrasound applied during electrodeposition can improve the reaction rate and feature of the deposit. Mass transport, diffusion layer thickness and surface morphology are greatly enhanced by ultrasound [1-4]. Aim of this work was deposition and characterization of Zn-Co alloy. Deposition was performed galvanostatically, with deposition current density 2 A dm<sup>-2</sup>. Magnetic stirrer and two different amplitude of ultrasound were used and compared. Ultrasound was generated by ultrasound horn. Applied vibration amplitudes in continuous mode were 25% and 55%, corresponding to 20 and 30 W cm<sup>-2</sup> powers, respectively. Galvanostatic curves show that deposition potential is shifted to more noble values when ultrasound is applied, compared to silent deposition. Morphology of the deposited coatings was analyzed by FESEM. Chemical composition was estimated by EDAX coupled with SEM. Cobalt content in coating has increased by applied ultrasound. The structure, texture and preferred orientation were determined by X-ray diffraction. Corrosion stability of the Zn-Co coating was assessed based on the electrochemical impedance spectroscopy (EIS) results. EIS was recorded during exposure to 3% sodium chloride. The EIS results show that corrosion resistance of coatings obtained by ultrasound assisted electrodeposition was increased as compared to deposition with magnetic stirring. However, it was shown that too high ultrasound power negatively affects the structure of the coatings, resulting in lower corrosion stability.

### References:

1. M. Mouanga, L. Ricq, P. Bercot, *Surface & Coatings Technology* 202 (2008) 1645-1651
2. J. Bajat, V. Mišković-Stanković, M. Maksimović, D. Dražić, S. Zec, *Electrochimica Acta* 47 (2002) 4101-4112
3. J.L. Ortiz-Aparicio, Y. Measa, G. Trejo, R. Ortega, T.W. Chapman, E. Chainet, P. Ozil, *Electrochimica Acta* 52 (2007) 4742-4751
4. E. Garcia-Lecina, I. Garcia-Urrutia, A. Diez, J. Fornell, E. Pellicer, J. Sort, *Electrochimica Acta* 114, (2013) 859-867

## Evaluation of Zr and Ti coated stainless steel bipolar plates for polymer electrolyte membrane fuel cells

Aida Ghiulnare Pantazi<sup>1</sup>, Sabrina Rosoiu<sup>1</sup>, Eduard Grigore<sup>2</sup>, Marius Enachescu<sup>1</sup>, Liana Anicai<sup>1</sup>

<sup>a</sup>Center of Surface Science and Nanotechnology, University Politehnica of Bucharest, Splaiul Independentei 313, Bucharest, 060042, Romania

<sup>b</sup>Plasma Physics and Nuclear Fusion Department, National Institute for Laser, Plasma and Radiation Physics, P.O.Box MG-36, Magurele, Bucharest, Romania  
[aida.pantazi@cssnt-upb.ro](mailto:aida.pantazi@cssnt-upb.ro)

Fuel cells play an important role for the future energy supply due to the wide range of potential applicability for portable, mobile as well as stationary applications and combined heat and power generation.

One key component in the PEMFC (polymer electrolyte membrane fuel cell) which contributes significantly to cost and still needs to be improved to ensure cell lifetime is the bipolar plate (BPP). The BPP provides the structural integrity of the PEMFC stack and moreover serves three purposes, including separation of the fuel and oxidant gases, distribution of reactant gases to the cells and electron flow through the PEMFC stack.

The BPPs are expected to exhibit high corrosion resistance, low interfacial electrical resistivity, low gas permeability, good mechanical strength and high chemical stability under PEMFCs working conditions. Metallic materials including stainless steel (SS) have been used to build BPPs, due to their lower cost and higher stability. However usually they possess lower corrosion resistance. Therefore, coatings applied onto SS substrates are recommendable to improve the corrosion performance.

The paper presents several experimental results regarding the evaluation of Zr and Ti coatings deposited on SS by CMSII (Combined Magnetron Sputtering and Ion Implantation) and HiPIMS (High Power Impulse Magnetron Sputtering) methods. The morphological and electrical characterization of the coatings have been studied involving Atomic Force Microscopy (AFM). AFM images have been recorded in contact mode at ambient atmosphere (20x20  $\mu\text{m}^2$  and 10x10  $\mu\text{m}^2$ ). Local morphology features, as length and width of individual grains, as well as the roughness parameters, Ra (arithmetic average of measured microscopic peaks and valleys) and RMS (root mean square of measured microscopic peaks and valleys) were determined. The co-localized and simultaneous acquisition of the topographic maps, of the maps of friction forces and electrical conductivity distribution was performed, too. The corrosion performance has been screened using electrochemical polarization tests in aqueous electrolytes containing 0.1 - 11.5 ppm HF in 0.5M sulfuric acid at pH 3, for temperatures in the range 27-70°C.

The results showed that Zr coatings onto SS exhibit corrosion current values between 1.05-1.27  $\mu\text{A}/\text{cm}^2$ , which satisfy the EU target and are very close by the 2020 DOE target.

*Acknowledgements:* This project has received funding from the ROFCC project, Contract No. 25 PCCDI/2018 and from the European Union's Horizon 2020 research and innovation programme under the Marie Skłodowska-Curie grant agreement No764977.

## Electrochemical and morphological investigations of poly(3,4-ethylenedioxyppyrrrol) films

Krisztina J. Szekeres, Mária Ujvári, Gyözö G. Láng

Department of Physical Chemistry, Institute of Chemistry, Laboratory of Electrochemistry and Electroanalytical Chemistry, Eötvös Loránd University, Pázmány Péter sétány 1/A, 1117 Budapest, Hungary  
[szekkriszt@caesar.elte.hu](mailto:szekkriszt@caesar.elte.hu)

Poly(3,4-ethylenedioxyppyrrrol) (PEDOP) films on gold substrate were prepared by electropolymerization of ethylenedioxyppyrrrol monomer (EDOP) under potentiodynamic conditions in aqueous sodium sulfate solutions [1]. The PEDOP films and the Au | PEDOP | sulfuric acid electrodes were characterized using electrochemical impedance spectroscopy, scanning electron microscopy and energy dispersive x-ray analysis. According to the results, depending on the storage history of the monomer solutions two distinct types of polymer films were formed. By using "fresh" (as-purchased) monomer solutions, polymer films with nearly ideal capacitive behavior were obtained and almost rectangular-shaped cyclic voltammograms could be observed in a rather broad potential range. According to the SEM images (Fig.1.a) the polymer layer on the gold substrate was relatively smooth, only some small cracks could be observed on the surface. Impedance spectra revealed that the charge transfer resistance between the substrate and the film was low. In contrast working with "old" monomer solution that was not properly stored, the shapes of the cyclic voltammograms recorded at the Au | PEDOP | 0.1 M sulfuric acid (aq) electrode exhibited two peaks, a reduction peak at about  $-0.2$  V vs. SSCE and an oxidation peak close to  $0.2$  V vs. SSCE and the charge transfer resistances were considerably higher than those estimated for the electrode prepared using "fresh" monomer solutions. SEM images showed (Fig.1.b) that the surface of the polymer film was extremely rough, with several wrinkles, creases, and large cracks. The polymer films prepared using freshly distilled monomer showed similar behavior to those prepared starting from "as purchased" monomer, however, the charge transfer resistance was lower and SEM images showed smoother and more homogeneous surfaces.

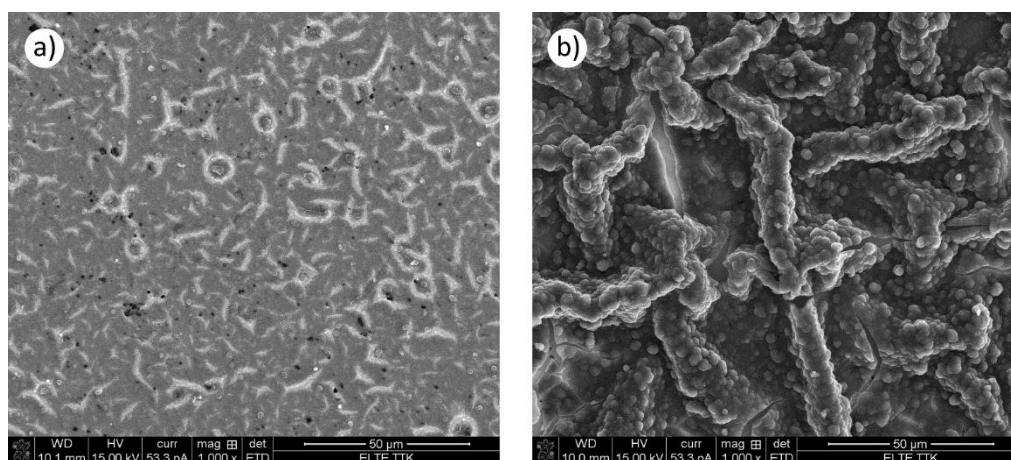

Figure 1. Secondary electron SEM images of the PEDOP layers were prepared by using (a) "fresh", (b) "old" monomer. The length of the horizontal white bar below the images corresponds to  $50 \mu\text{m}$ .

**Acknowledgment:** This work was supported by the ÚNKP-18-3 New National Excellence Program of the Ministry of Human Capacities and by NKFI - OTKA (grant No. K 129210). The research within project No. VEKOP-2.3.2-16-2017-00013 was supported by the European Union and the State of Hungary, co-financed by the European Regional Development Fund.

### References

1. K. J. Szekeres, K. Hegedüs, M. Ujvári, and G. G. Láng, *Journal of Electroanalytical Chemistry* **826** (2018) 16-22.

## Investigation of the electrodeposition and dissolution of lead dioxide using electrochemical quartz crystal microbalance (EQCM)

Balázs Broda, György Inzelt

Eötvös Loránd University, Department of Physical Chemistry, Pázmány Péter sétány 1/A,  
H-1117 Budapest, Hungary  
[balazsbroda@gmail.com](mailto:balazsbroda@gmail.com)

Metal and metal-oxide layers are widely used in industrial applications because of their high variability and diversity. Electrodeposition is a common method to prepare these types of films because their morphology and thickness can be easily adjusted by the conditions of the experiments (e.g., temperature and composition of the electrolyte, duration of the process, material and quality of the substrate, type of the electrochemical method, etc.). Compact layers and multilayers with very complex shapes can be also made by these techniques. Lead dioxide films have been used for bipolar and semi-bipolar batteries, waste water treatment and many other purposes. The electrochemical study of lead<sup>1</sup> and lead dioxide<sup>2</sup> layers is an important field of lead-acid battery research to improve the efficiency and life-time of energy storage systems. In this work, relatively thick lead dioxide layers were electrodeposited on gold and platinum substrates, respectively, from aqueous solutions of lead(II) nitrate dissolved in nitric acid and perchloric acid, respectively. The electrodeposition was carried out using cyclic voltammetry (Fig. 1a) and chronoamperometry (Fig. 1b).

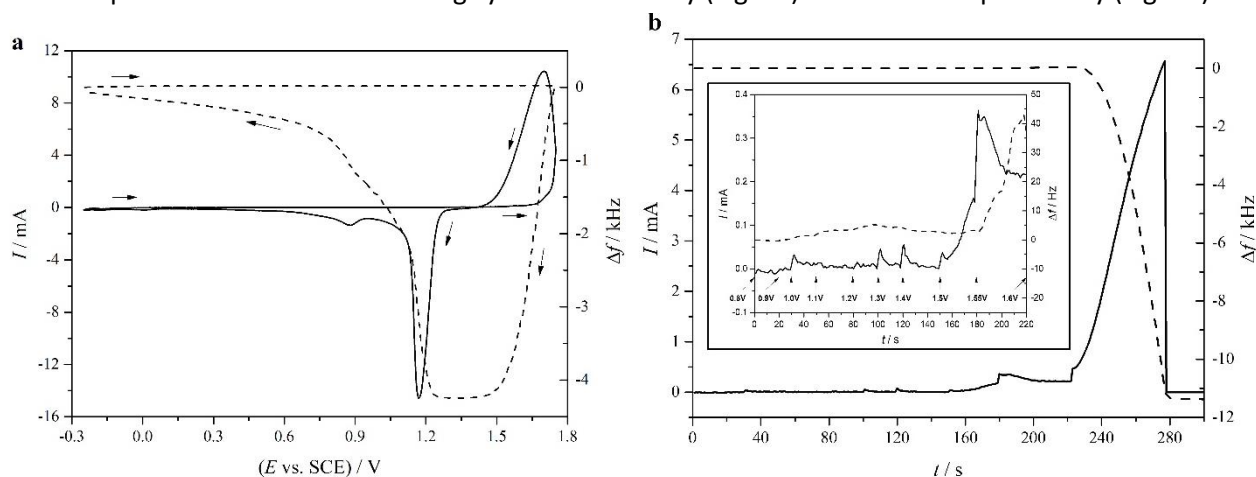

Figure 1a: Cyclic voltammograms (solid lines) and simultaneous frequency measurements (dashed lines) at a scan rate of  $20 \text{ mVs}^{-1}$ ; b: Chronoamperometric curves (solid lines) and simultaneous frequency measurements (dashed lines) during electrodeposition of lead dioxide (working electrode: gold-coated quartz crystal; electrolyte:  $0.1 \text{ M Pb(NO}_3)_2$  dissolved in  $1.0 \text{ M HNO}_3$  solution)

The mass changes during  $\text{PbO}_2$ -film formation and dissolution were followed by in situ electrochemical quartz crystal microbalance (EQCM). Although, the electrodeposition of lead dioxide on several types of substrates and in different electrolytes has been widely investigated, the mechanism of its dissolution has not been explored yet. The rate of the reactions occurring during the electroreduction of the film is very different depending on the electrolytes, the substrates, the applied potential, the scan rate, etc. The pH has a small effect on reversibility but highly influences the properties and the deposited quantity of lead dioxide layer. At lower concentrations of nitric acid, the  $\text{PbO}_2$  can be reduced in a larger potential range which is most likely related to the variation of the conductivity of the deposited layer as well as on the nature of the intermediate species.

### References

1. M. Taguchi, H. Sugita, *Journal of Power Sources* **109** (2002) 294-300 ([https://doi.org/10.1016/S0378-7753\(02\)00056-3](https://doi.org/10.1016/S0378-7753(02)00056-3))
2. D. Pech, T. Brousse, D. Bélanger, D. Guay, *Electrochimica Acta* **54** (2009) 7382-7388 (<https://doi.org/10.1016/j.electacta.2009.07.070>)

## Electrodeposition of Ag and Ag composites with carbon nanotubes using novel deep eutectic solvent formulations

Sabrina Rosoiu<sup>1</sup>, Aurora Petica<sup>1</sup>, Aida Ghiulnare Pantazi<sup>1</sup>, Marius Enachescu<sup>1</sup>, Teodor Visan<sup>1,2</sup>, Liana Anicai<sup>1</sup>

<sup>1</sup>Center of Surface Science and Nanotechnology, University Politehnica of Bucharest, Splaiul Independentei 313, Bucharest, 060042, Romania

<sup>2</sup>Department of Inorganic Chemistry, Physical Chemistry and Electrochemistry, Faculty of Applied Chemistry and Materials Science, University Politehnica of Bucharest, 132 Calea Grivitei, Bucharest, Romania  
[sabrina.rosoiu@cssnt-upb.ro](mailto:sabrina.rosoiu@cssnt-upb.ro)

The paper presents some experimental results regarding the electrodeposition and characterization of Ag and Ag composites with carbon nanotubes involving choline chloride based ionic liquids, also known as “deep eutectic solvents” (DES). The influence of applied current form, respectively of direct current vs. pulsed current on the deposit appearance and carbon nanotubes incorporation is also discussed.

Generally the experiments showed a difficulty to electrodeposit the Ag layer mainly due to the instantaneous nucleation process that determines the formation of a powdery deposit which further impedes a suitable adhesion. Under these circumstances, a novel DES electrolyte was proposed, consisting in choline chloride-triethanolamine (IL-TEA) eutectic mixture (1:1 molar ratio) sometimes also containing 0.1 M nicotinic acid (NA). Dispersion stability of multi-walled carbon nanotubes (MWCNTs) was found to be excellent in the used eutectic solvent. According to Raman, XPS and XRD analysis, the carbon nanotubes were successfully inserted into the metallic matrix, being also favoured by the use of pulsed current.

Metallic light grey coatings, with a good adherence and uniformity onto the Cu substrate have been obtained at a working temperature of 70-80°C and current density values between 2 -5 mA/cm<sup>2</sup>. XRD pattern suggested a good crystallinity of the Ag layer. The crystallites average sizes of 28-35 nm have been determined using the Scherrer equation.

For Ag-MWCNT composites, the Raman scattering intensities for the D and G bands of MWCNTs are significantly enhanced as compared to those of pure MWCNTs (see Fig.1), suggesting a potential use as a surface enhanced Raman scattering (SERS) substrate.

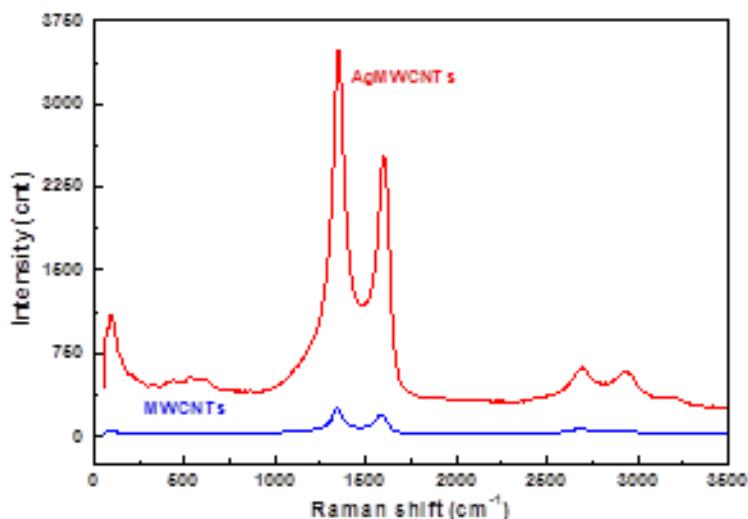

Figure 1. Raman spectra of Ag-MWCNT composite coating and commercial MWCNTs

**Acknowledgements:** The work was supported by Romanian Ministry of Education and by Executive Agency for Higher Education, Research, Development and Innovation Funding, under NOVTINALBEST project 38/2016, M Era Net Program and under ROFCC project, Contract No. 25 PCCDI/2018. S.P. acknowledges the financial support under the Marie Skłodowska-Curie grant agreement No764977.

## On the use of scanning Kelvin probe for the *in situ* assessment of the delamination of adhesively bonded joints

Barbara Priscila Andreon, Barbara Luiza Guenther<sup>1</sup>, Welchy Leite Cavalcanti<sup>1</sup>, Peter Plagemann<sup>1</sup>,  
Lucio Colombi Ciacchi<sup>2</sup>

*Institute for Manufacturing Technology and Advanced Materials Fraunhofer IFAM, 28359 Bremen, Germany*

<sup>1</sup>*Institute for Manufacturing Technology and Advanced Materials Fraunhofer IFAM,  
28359 Bremen, Germany*

<sup>2</sup>*University of Bremen, Hybrid Materials Interfaces Group, Faculty of Production Engineering, Center for  
Environmental Research and sustainable Technologies and MAPEX Center for Materials and Processes,  
28359 Bremen, Germany*

[andreon@ifam.fraunhofer.com](mailto:andreon@ifam.fraunhofer.com)

Many industries nowadays rely on the adhesive bonding technology for their success, most notably aerospace, automotive, construction, and the electronics industry. In comparison to other joining methods, the main advantages of the adhesive bonding are its ability to bond dissimilar materials, to guarantee an efficient load transfer, and to preserve the integrity of the joined parts. In addition, adhesive bonding is in many cases the most convenient and cost-effective joining technique and, in fact, the bonding process can often be automated.

Several industrial applications request the adhesive joint to withstand loads under different environmental conditions such as high moisture, and extreme temperatures. Estimating the lifetime of adhesively bonded joints under such environments is crucial to support tailoring the properties for the respective application demand. The loss of strength in a joint might occur, for instance, due to hydrodynamic displacement of adhesive from the substrate, adhesive plasticization, or substrate corrosion [1]. Once a deep fundamental understanding of bond degradation is achieved, interphases between adhesively bonded materials can be designed with increased stability and decreased complexity.

This work presents a novel application of the scanning Kelvin probe (SKP) to investigate *in situ* the delamination kinetics of closed adhesive joint geometries, using a similar approach as for the delamination of coatings [2,3]. In order to probe with SKP the local interfacial electrochemical potentials at a buried metal/metal-oxide/polymer interphase, a second substrate made of thin borosilicate glass is employed. This does act as a diffusion barrier layer, but still allows SKP measurements to be performed. In addition to SKP measurements, chemical details of the delamination mechanisms taking place at the interphase are analyzed a posteriori by means of X-ray photoelectron spectroscopy (XPS), after the removal of the adhesive layer.

### References

1. Pethrick, Richard A. (2014): Design and ageing of adhesives for structural adhesive bonding – A review. In: Proceedings of the Institution of Mechanical Engineers, Part L: Journal of Materials: Design and Applications 229 (5), S. 349–379. DOI: 10.1177/1464420714522981.
2. Hausbrand, René; Stratmann, Martin; Rohwerder, Michael (2009): Corrosion of zinc–magnesium coatings. Mechanism of paint delamination. In: Corrosion Science 51 (9), S. 2107–2114. DOI: 10.1016/j.corsci.2009.05.042.
3. Leng, A.; Streckel, H.; Stratmann, M. (1998): The delamination of polymeric coatings from steel. Part 1. Calibration of the Kelvinprobe and basic delamination mechanism. In: Corrosion Science 41 (3), S. 547–578. DOI: 10.1016/S0010-938X(98)00166-8.

## Characterization of cobalt(II)-4-nitrocatechol and cobalt(II)-humic acid complexes in aqueous solution

Andela Bačinić, Marina Mlakar

Rudjer Boskovic Institute, Bijenička 54, 10 000 Zagreb

[abacinic@irb.hr](mailto:abacinic@irb.hr)

Cobalt (II) as an essential element and important for biochemical processes in the marine environment, is bioavailable in its dissolved form. It is known that in seawater cobalt is partially, but strongly complexed to natural organic ligands. Dissolved cobalt(II) is very important element for all marine organisms (biochemical and physiological functioning). Despite its abundance in the environment, dissolved  $\text{Co}^{2+}$  in the oceans is present at low concentrations,  $<10^{-9} \text{ mol dm}^{-3}$ , mostly in organic complexes. [1] By its complexing with 4-nitrocatechol and humic acid, complex components of the natural organic matter present in seawater, cobalt(II) forms soluble complexes in aqueous solutions. [2] Electrochemical characterization of cobalt (II) complexes with 4-nitrocatechol and humic acid in aqueous solution ( $0.55 \text{ mol dm}^{-3} \text{ NaCl}$ ) using square wave and cyclic voltammetry, was performed. Cobalt(II) concentrations varied from 1 to  $5 \times 10^{-5} \text{ mol dm}^{-3}$ , 4-nitrocatechol from 1 to  $5 \times 10^{-5}$  and humic acid from 0.1 to  $0.9 \text{ mg dm}^{-3}$ . First reduction peak of Co(II)-4-nitrocatechol was recorded at  $E_p$  -0.8 V while the second one at -1.1 V. At the same potential was registered reduction peak of Co(II)-humic acid complex (Figure 1. A and B). That suggests that nitro group is the binding functional group for cobalt with the humic acid ligand. (Figure 1; inset). Investigated cobalt(II)-complexes reduction were recorded in the pH range from 5 to 9.5. Reduction currents reached maximum at  $\approx \text{pH}$  6.5. Further investigations were performed at pH of the seawater. The reduction mechanism of both complexes was investigated by square-wave voltammetry with variation of parameters: frequency, amplitude and step increment. Based on the theory of the reduction current and potential dependencies on SW frequency, it was confirmed that the redox process of both Co(II)-complexes is irreversible. SW amplitude showed exponential increase characteristic for irreversible redox process with the reactant adsorption. [3] CV voltammograms recorded irreversible cathodic peaks. Using NTA as competing ligand, a stoichiometry of the Co(II)-4-nitrocatechol complex (at  $\approx -0.8 \text{ V}$ ) was presumed to be 1:1, 1:2 and 1:3. EDTA was used as competing ligand for titration with humic acid and a stoichiometry of the Co(II)-humic acid complex (at  $\approx -1.1 \text{ V}$ ) was presumed to be 1:2 [4]. UV/VIS spectra were recorded under the same conditions experimental conditions. Titration data (changes in complete spectra) were processed by multivariate non-linear least-square fitting program [5]. Obtained results show that 4-nitrocatechol and humic acid form soluble  $\text{Co}^{2+}$  complexes in the pH range from 5 to 9 that remain in the solution for a sufficient period of time to be available for phytoplankton.

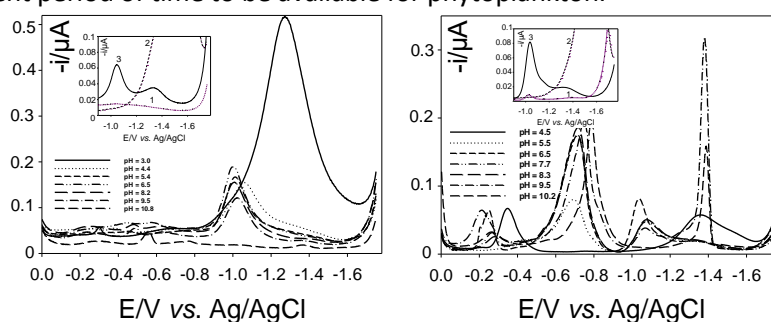

Figure 1. Dependence of Co(II)- complexes on pH. A)  $C_{\text{Co}} = 4 \times 10^{-5} \text{ mol dm}^{-3}$ ,  $Y_{\text{humic acid}} = 0.9 \text{ mg dm}^{-3}$ .  
 Insert: SW voltammograms of humic acid, cobalt, Co(II)-humic acid complex in  $0.55 \text{ mol dm}^{-3} \text{ NaCl}$ ; pH 8.2 B)  
 $C_{\text{Co}} = 4 \times 10^{-5} \text{ mol dm}^{-3}$ ,  $C_{\text{cat}} = 1 \times 10^{-5} \text{ mol dm}^{-3}$ . Inset: SW voltammograms of 4-nitrocatechol, cobalt,  
 Co(II)-4-nitrocatechol complexes in  $0.55 \text{ mol dm}^{-3} \text{ NaCl}$ ; pH 8.2

1. M.J. Ellwood, C.M.G. van den Berg, *Marine Chemistry* **75**(2001), 33–47.
2. M. Vega, C.M.G. van den Berg, *Anal. Chem.* **69**(1997), 874–881.
3. M. Lovrić, Š. Komorsky-Lovrić, *J. Electroanal. Chem.* **248**(1988) 239–253.
4. M.G. van den Berg, *Marine Chemistry*, **50** (1995) 139–157
5. P. Cmuk, I. Piantanida, M. Mlakar, *Electroanalysis* **21**(23) (2009) 2527 – 2534.

## Investigation of formation and stability of V(IV)-EDTA and V(V)-EDTA complexes using Hanging Mercury Drop Electrode

Lucija Knežević, Elvira Bura-Nakić

Ruđer Bošković Institute, Bijenička 54, 10 000 Zagreb

[lucija.knezevich1@outlook.com](mailto:lucija.knezevich1@outlook.com)

Vanadium is considered a relatively abundant element, where its share in natural samples is estimated to be around 0.019 %.[1] Interest in Vanadium is derived from the occurrence of the common redox states in Earth surface environments(+3, +4, +5) as a consequence of Vanadium's geochemical evolution. Vanadium chemical speciation and solubility is a complex function of pH, Eh, concentration, solution chemistry and many other factors.[2] Reduced species have a strong tendency to oxidize quickly, making the speciation of Vanadium very demanding. Based on former studies on Vanadium speciation, it has been found that Vanadium reduced species form stable complexes with EDTA. In order to optimize chromatographic separation of V(III)-EDTA, V(IV)-EDTA and V(V)-EDTA we investigated the stability of V-EDTA complexes through electrochemical behavior of solutions containing V(IV) and V(V). Analysis were made using differential pulse voltammetry (DPV) at a hanging mercury drop electrode (HMDE). The experiments were carried out on 2.78, 3.0, 3.3, 3.6, 4.1, and 6.3 pH values of solutions, respectively. Results show strong pH dependence of V electrochemical behavior at the HMDE. In more acid conditions for both species, *i.e.* V(IV) and V(V) one pronounced voltammetric peak is observed, whereas on more alkaline pH values, same species are characterized by two peaks. It has been found that on lower pH values, single peak is a result of V(IV) to V(II) reduction. However, on higher pH values observed reduction peaks can be assigned to the one electron reduction of V(V) to V(IV) ions and again to the two electron reduction of V(IV) to V(II) ions, respectively. This is in agreement with the reported behavior using differential pulse polarography (DPP) and cyclic voltammetry (CV) for solutions containing V(V).[3] Also the solutions containing V(IV) and V(V) were titrated with EDTA in order to examine stability of formed complexes. During titrations it can be seen that the wave of free V-species reduces due to the complexation with EDTA. In the same time another wave is forming which can be attributed to V(IV)-EDTA complex or V(V)-EDTA complex, respectively. Derived stability constants of formed complexes are found to be in agreement with available literature data.[4] It has been found that complexation of V species with EDTA is also pH dependent. At lower pH values voltammetric wave characteristic for free V(IV) and V(V) is diminishing after EDTA concentration added are approximately equal to the starting free V concentration indicating 1:1 V vs. EDTA stoichiometry. At higher pH values concentration of added EDTA needed to titrate free V voltammetric wave are two or more times higher. Moreover, also the shift free V wave towards negative values of potential with increasing pH of the solution is observed. This behavior is in accordance with the formation of stable hydrolyzed polynuclear complexes of V species on higher pH values.[1] All the listed results will be compared with the spectrophotometry measurements of V(IV) and V(V) solutions behavior at different pH values.

### References

1. E. del Carpio, L. Hernández, C. Ciangherotti, V.V illalobos Coa, L. Jimenez, V. Lubes, G. Lubes, *Elsevier B.V.* (2018.) (<https://doi.org/10.1016/j.ccr.2018.06.002>)
2. J. H. Huang, F. Huang, L. Evans, S. Glasauer, *Elsevier B.V.* (2015) (<http://dx.doi.org/10.1016/j.chemgeo.2015.09.019>)
3. C. G. Azevedo, I. Correia, M .M. C. dos Santos, M .F. A. Santos, T. Santos-Silva, J. Douth, L. Fernandes, H. M. Santos, J. L. Capelo, J.C. Pessoa, *Journal of Inorganic Biochemistry* (2017) (<https://doi.org/10.1016/j.jinorgbio.2017.12.012>)
4. [https://www.dojindo.com/Images/Product%20Photo/Chelate\\_Table\\_of\\_Stability\\_Constants.pdf](https://www.dojindo.com/Images/Product%20Photo/Chelate_Table_of_Stability_Constants.pdf)
5. X. Sherry Li, X. Chris Le, *Elsevier B.V.* (2007.) (<https://doi:10.1016/j.aca.2007.09.004>)

## Determination of surface activity of natural organic matter by using pulsed techniques

Saša Marcinek, Dijana Jadreško, Dario Omanović

Division for Marine and Environmental Research, Ruđer Bošković Institute, 10000 Zagreb, Croatia  
[smarcin@irb.hr](mailto:smarcin@irb.hr)

Dissolved organic matter (DOM) is an important constituent of all aquatic ecosystems. In coastal regions DOM is in big part composed of humic substances (HS). A non-negligible fraction of DOM in aquatic environments consists of various surface active chemical species. Surface active substances (SAS) are considered as electro-inactive. However, the influence they have on the double layer due to their adsorption onto the surface the electrode enables their quantification. Molecular characterization relies solely by comparison with model compounds. Alternating current voltammetry (ACV) is commonly used technique for SAS studies [1]. During adsorption electrical double layer capacitance decreases, causing decrease in AC capacitive current. Square-wave voltammetry (SWV) and differential pulse voltammetry (DPV) methods are considered as "insensitive" to capacitive current. Applying these techniques for SAS measurements usually cause a sudden increase in adsorption and desorption current due to change in charge. This is seen as two peaks between which the current is very low, signifying the area of maximum adsorption [2]. Studying interactions of copper (Cu) with humic substances (fulvic and humic acids) a specific behavior of voltammograms while using SWV and DPV methods was observed. While the ACV method shows characteristic current decrease, these methods show elevation of whole background current with respect to increase of HS concentration and/or accumulation time, without adsorption-desorption peaks (Fig. 1). The same behavior was observed also without added Cu. This specific performance of background current in presence of naturally occurring SAS could be used for analytical purposes. The advantage of the proposed approach is that it could be used for simultaneous (I) determination of humic-SAS, (II) their interaction with copper (Cu), and (III) determination of sulfur species (e.g. thiols) along with the studies of potential iodide influence. The new optimized procedure is tested and verified on model solutions (IHSS fulvic and humic acid and DOM fractions extracted from seawater using XAD resins) and real samples from the Krka River estuary. The new approach is suggested as an alternative method for SAS measurements in natural water samples.

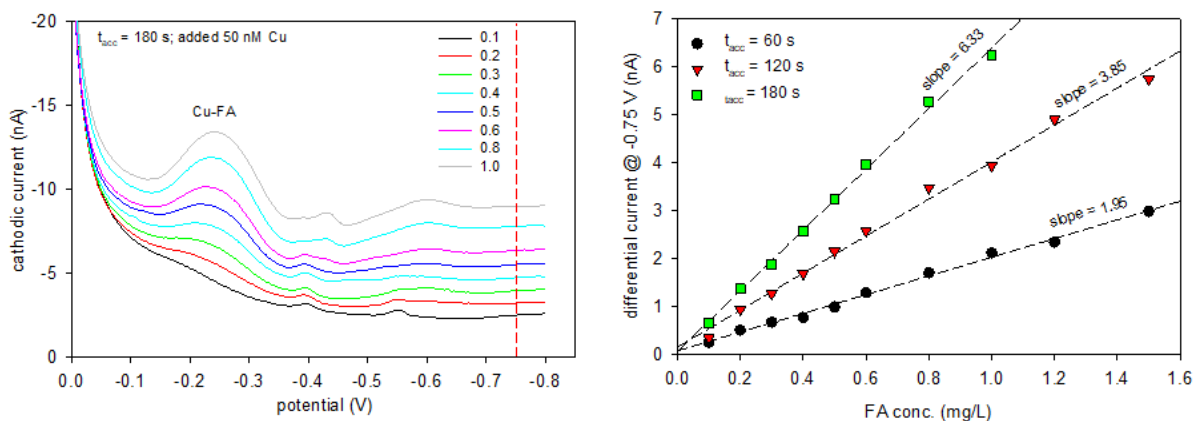

Figure 1. Voltammograms obtained in UV seawater using DPV method (left) and calibration curves at different accumulation times (right) with increasing fulvic acid (FA) concentration in the presence of 50 nM Cu (current reading corresponds to baseline corrected voltammograms at 0 s adsorption time). The accumulation potential was +0.03 V. Current intensity used for calibration curves and reading of the equivalent of FA concentration was read-out at potential -0.75 V (red vertical dashed line).

**Acknowledgement:** This research was realized within the MEBTRACE project (IP-2014-09-7530), financially supported by the Croatian Science Foundation.

### References

1. B. Ćosović, V. Vojvodić, *Electroanalysis* **22** (1998) 429-434
2. D. Jadreško, M. Zelić, *Electroanalysis* **27** (2015) 1669-1675.

## Hyphenation of scanning electrochemical microscopy and scanning ion conductance microscopy using photoresist-coated micropipettes

Stefan Wert, Timo Raith, Frank-Michael Matysik

*University of Regensburg, Universitätsstr. 31, 93053 Regensburg*

[frank-michael.matysik@chemie.uni-regensburg.de](mailto:frank-michael.matysik@chemie.uni-regensburg.de)

Scanning electrochemical microscopy (SECM) has proven to be a powerful method for the investigation of electrochemical properties of surfaces. For acquiring simultaneous information about the sample topography, scanning ion conductance microscopy (SICM) can be utilized. The hyphenation of these two techniques can be realized by using a micropipette with an integrated ring ultramicroelectrode (UME) as probe. Therefore, a simple approach for the fabrication of ring UMEs is presented. The fabrication of UMEs was performed by coating platinum-coated, pulled glass capillaries with a photoresist. Usually, multiple layers had to be applied for obtaining functional UMEs. The coating process was investigated by optical microscopy and scanning electron microscopy imaging, as well as cyclic voltammetry.

The electrochemical behavior and the topography of a patterned platinum substrate electrode and an interdigitated electrode array were investigated by the means of combined SECM and SICM. Electrochemical experiments were carried out with ferrocenemethanol (1.5 mM) as redox mediator and potassium nitrate (0.2 M) as supporting electrolyte in the bulk solution.